



US006142446A

# United States Patent [19] Leinsing

[11] **Patent Number:** **6,142,446**  
[45] **Date of Patent:** **Nov. 7, 2000**

[54] **MEDICAL ADAPTER HAVING NEEDLELESS VALVE AND SHARPENED CANNULA**

[75] Inventor: **Karl R. Leinsing**, Raleigh, N.C.

[73] Assignee: **Alaris Medical Systems, Inc.**, San Diego, Calif.

[21] Appl. No.: **09/197,017**

[22] Filed: **Nov. 20, 1998**

### Related U.S. Application Data

[63] Continuation of application No. 08/794,404, Feb. 2, 1997, Pat. No. 5,839,715, which is a continuation-in-part of application No. 08/705,062, Aug. 29, 1996, Pat. No. 5,676,346, which is a continuation of application No. 08/442,025, May 16, 1995, abandoned.

[51] **Int. Cl.**<sup>7</sup> ..... **F16K 51/00**

[52] **U.S. Cl.** ..... **251/149.1; 251/149.6; 604/256; 604/905**

[58] **Field of Search** ..... **251/149.1, 149.6; 604/256, 905**

### [56] **References Cited**

#### U.S. PATENT DOCUMENTS

Re. 35,841	7/1998	Frank et al.	604/256
4,425,122	1/1984	Cohen	604/237
4,874,377	10/1989	Newgard et al.	604/167
4,981,469	1/1991	Whitehouse et al.	604/86
5,064,416	11/1991	Newgard et al.	604/167
5,120,324	6/1992	Sancoff	604/283
5,122,123	6/1992	Vaillancourt	604/192
5,188,620	2/1993	Jepson et al.	604/283
5,251,873	10/1993	Atkinson et al.	251/149.1
5,295,658	3/1994	Atkinson et al.	251/149.1
5,330,450	7/1994	Lopez	604/283
5,338,313	8/1994	Molenauer et al.	604/229
5,344,414	9/1994	Lopez et al.	604/283
5,402,982	4/1995	Atkinson et al.	251/149
5,470,319	11/1995	Mayer	604/167
5,509,433	4/1996	Paradis	137/1

5,616,129	4/1997	Mayer	604/167
5,616,130	4/1997	Mayer	604/167
5,699,821	12/1997	Paradis	137/1
5,806,831	9/1998	Paradis	251/149.1
5,820,601	10/1998	Mayer	604/167

### FOREIGN PATENT DOCUMENTS

0 309 771 A1	9/1988	European Pat. Off.	A61M 5/00
0 453 264 A1	4/1991	European Pat. Off.	.
0453265	10/1991	European Pat. Off.	.
0 497 229 A1	1/1992	European Pat. Off.	.
3303718 C1	4/1984	Germany	A61M 5/14
WO 93/20772	10/1993	WIPO	.
WO 9528195	10/1995	WIPO	.

*Primary Examiner*—A. Michael Chambers  
*Attorney, Agent, or Firm*—Fulwider, Patton Lee & Utecht, LLP

### [57] **ABSTRACT**

A medical adapter having both a needleless valve and a sharpened cannula is used to connect or adapt pierceable septa containers or other devices having different sizes to needleless connection. The adapter includes a needleless site at one end and a sharpened cannula at the other end protected by spring arms. These arms include claws at their distal ends to grasp the neck of the pierceable septum device to which the sharpened cannula is to be inserted. The claws include sharpened points for gripping the device. The arms are located on either side of the adapter body and are connected to the body through springs. Handles are also included on the arms for use by the operator to separate the arms against the spring forces during engagement of the adapter with the septum. In one case, the handles include finger grips located above the springs for pressing the handles inward to open the arms and claws and in another case, the handles are located closer to the distal ends of the arms for pulling the arms outward. The adapter in one case comprises only three parts for reduced materials and manufacturing expense.

**20 Claims, 12 Drawing Sheets**

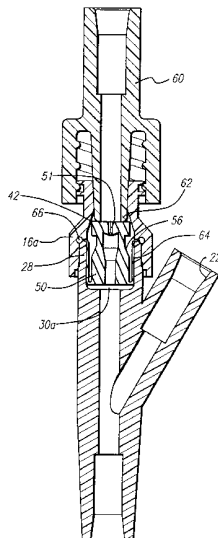

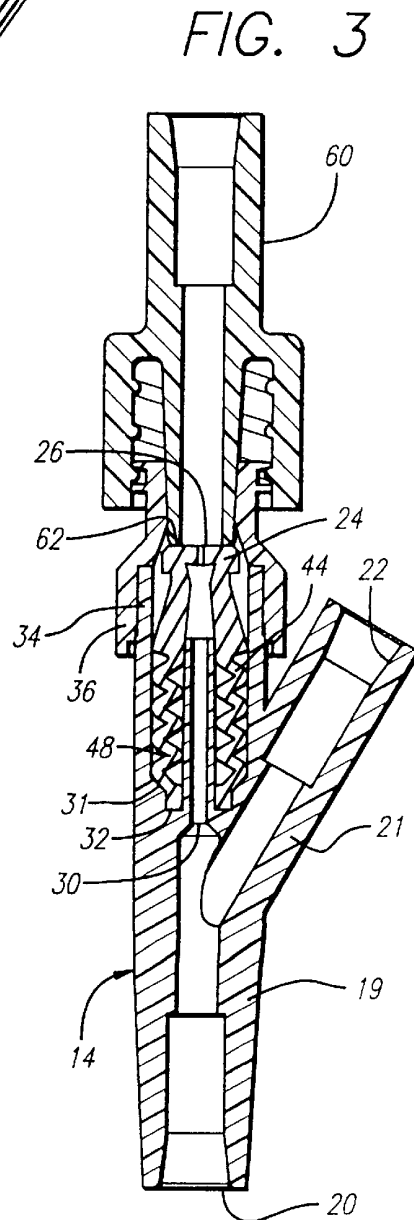
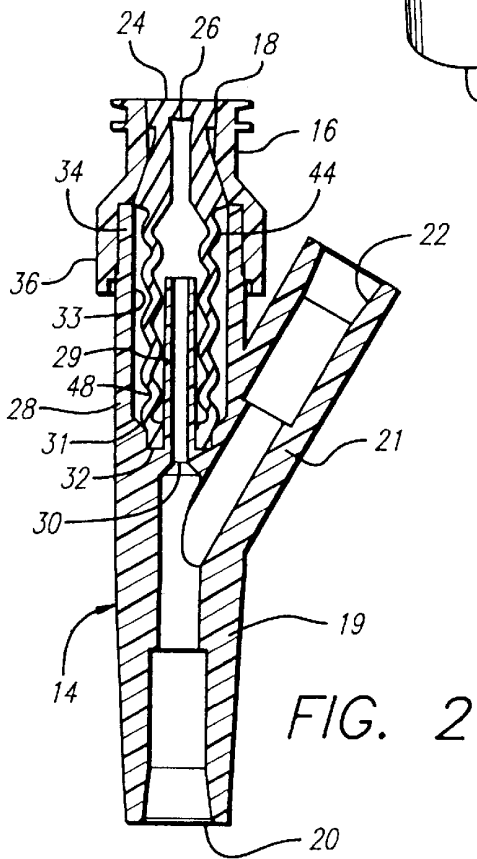
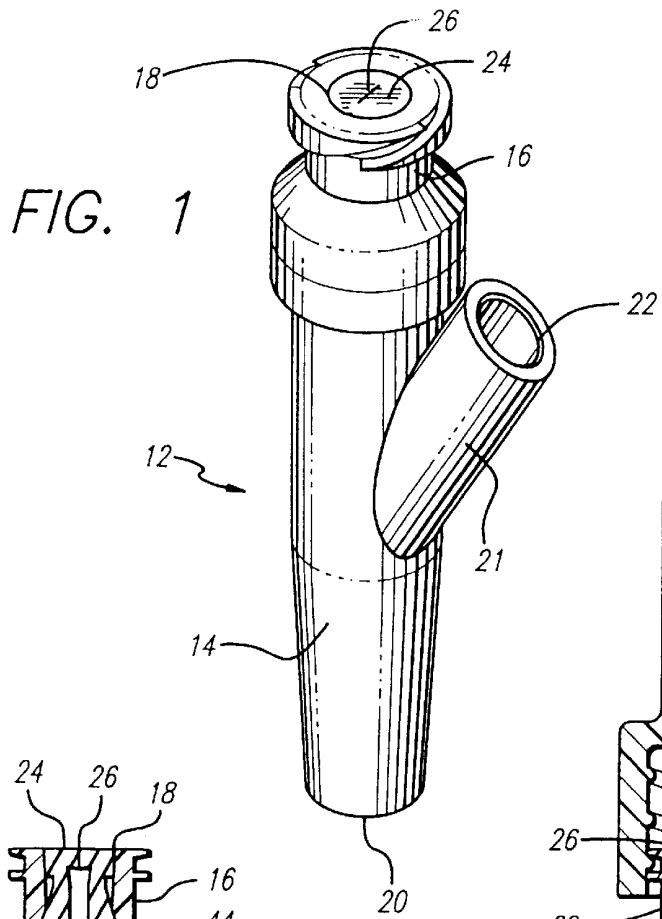

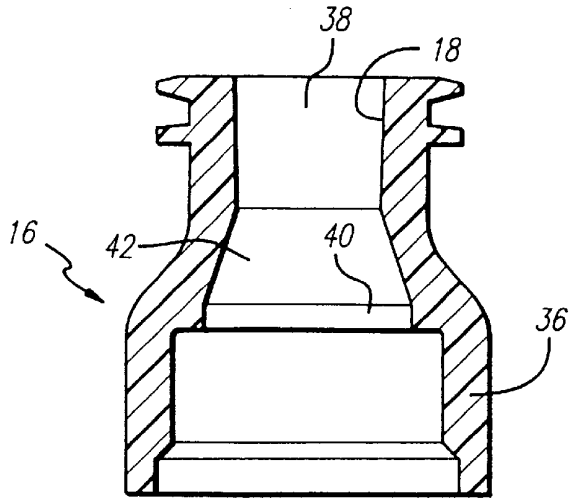

FIG. 6

FIG. 5

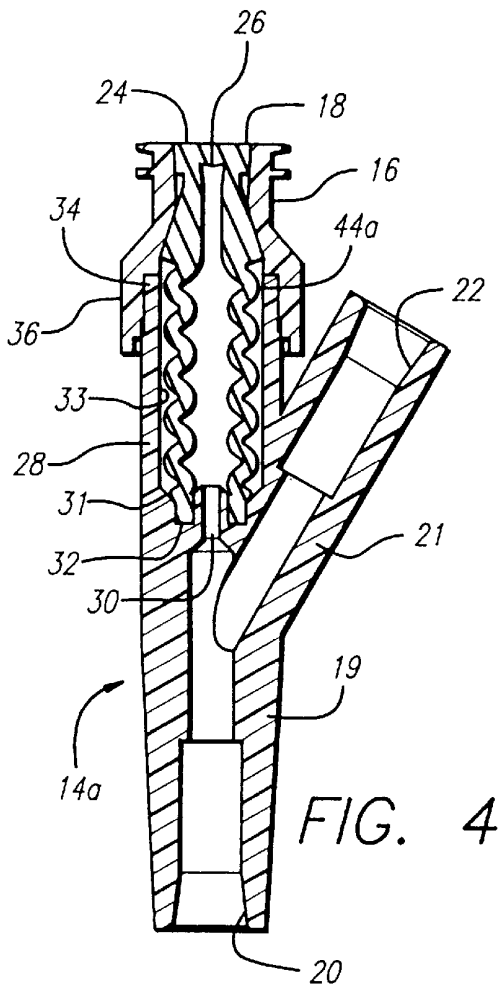
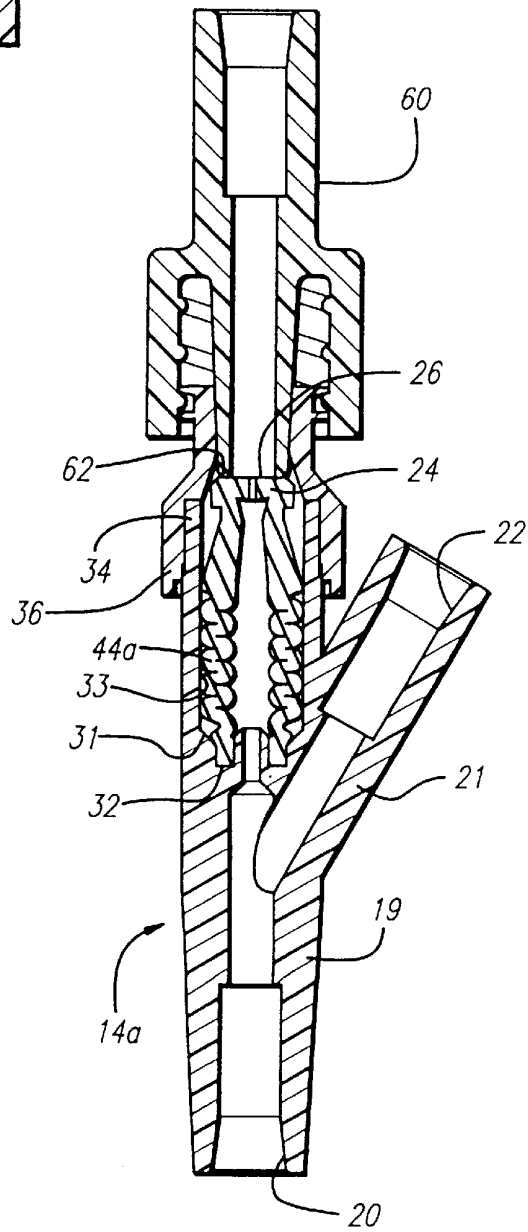

FIG. 4



20

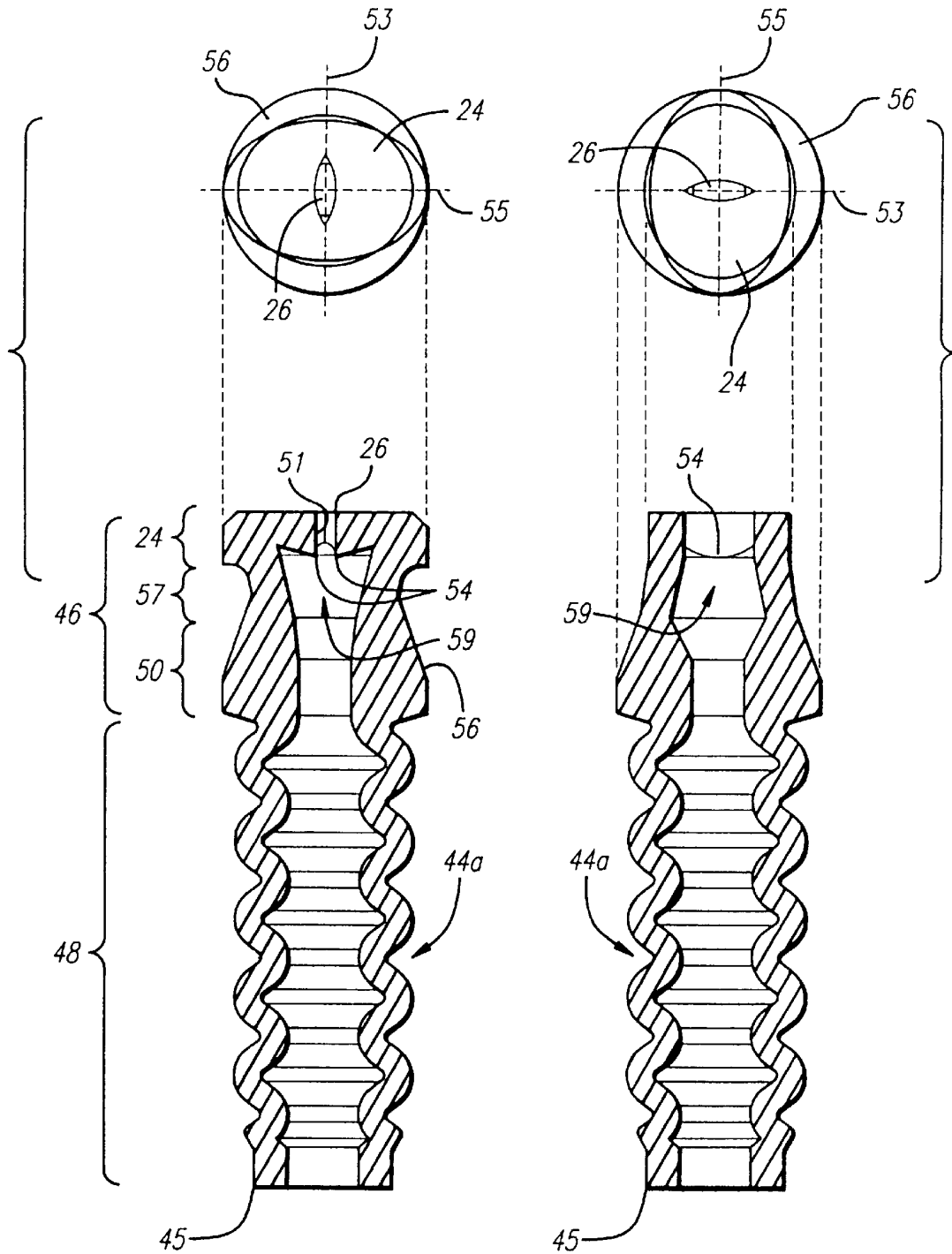

FIG. 7a

FIG. 7b

FIG. 8a

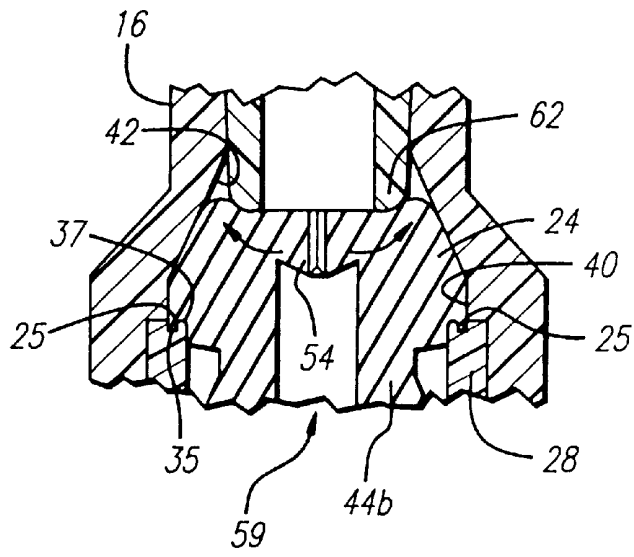
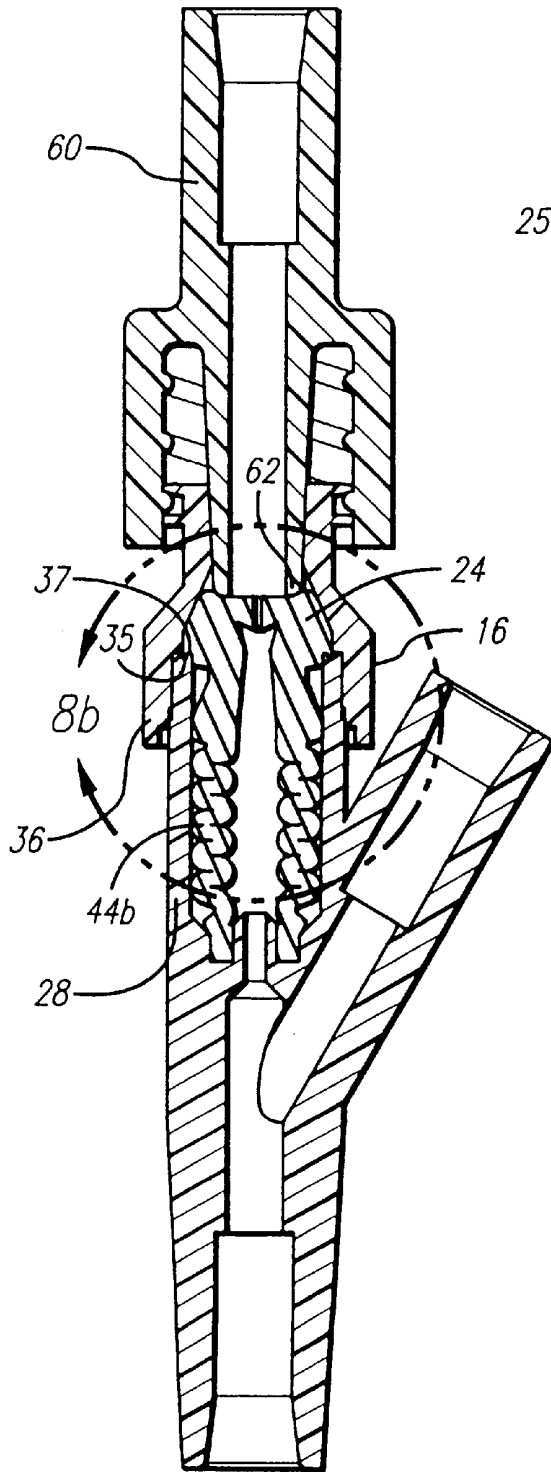

FIG. 8b

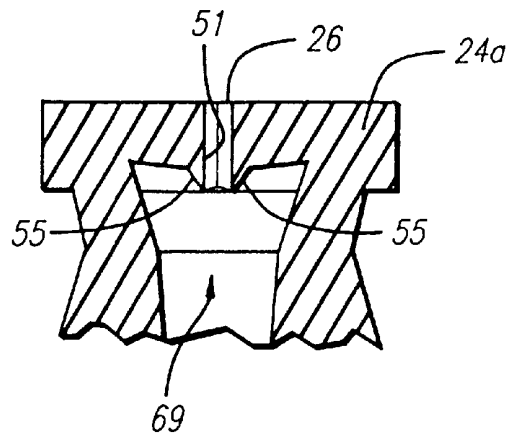

FIG. 9

FIG. 10b

FIG. 10d

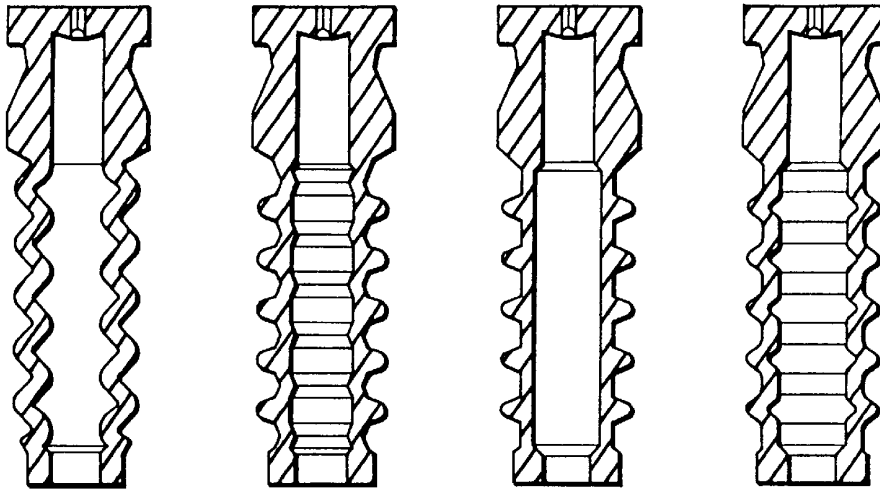

FIG. 10a

FIG. 10c

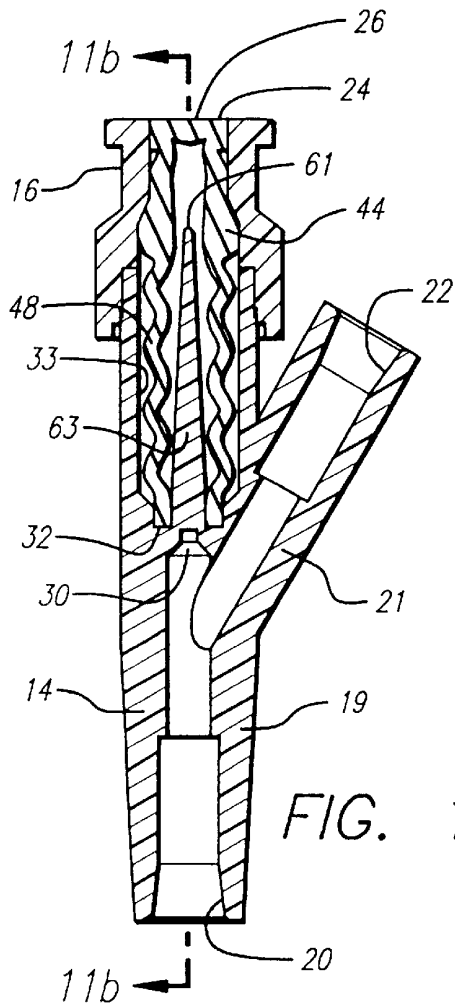

FIG. 11a

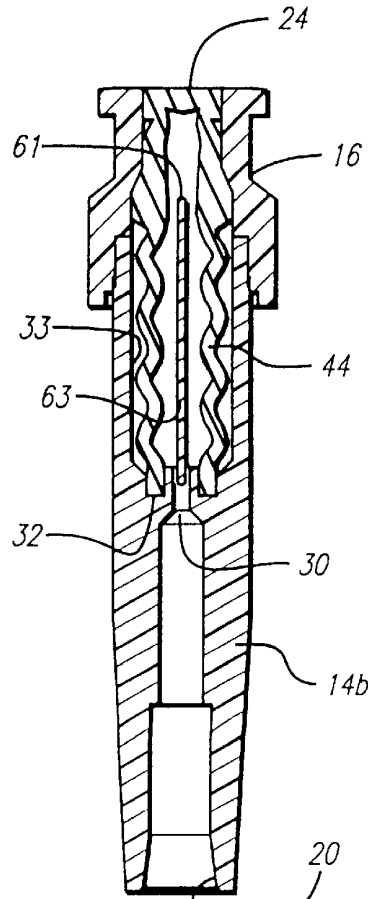
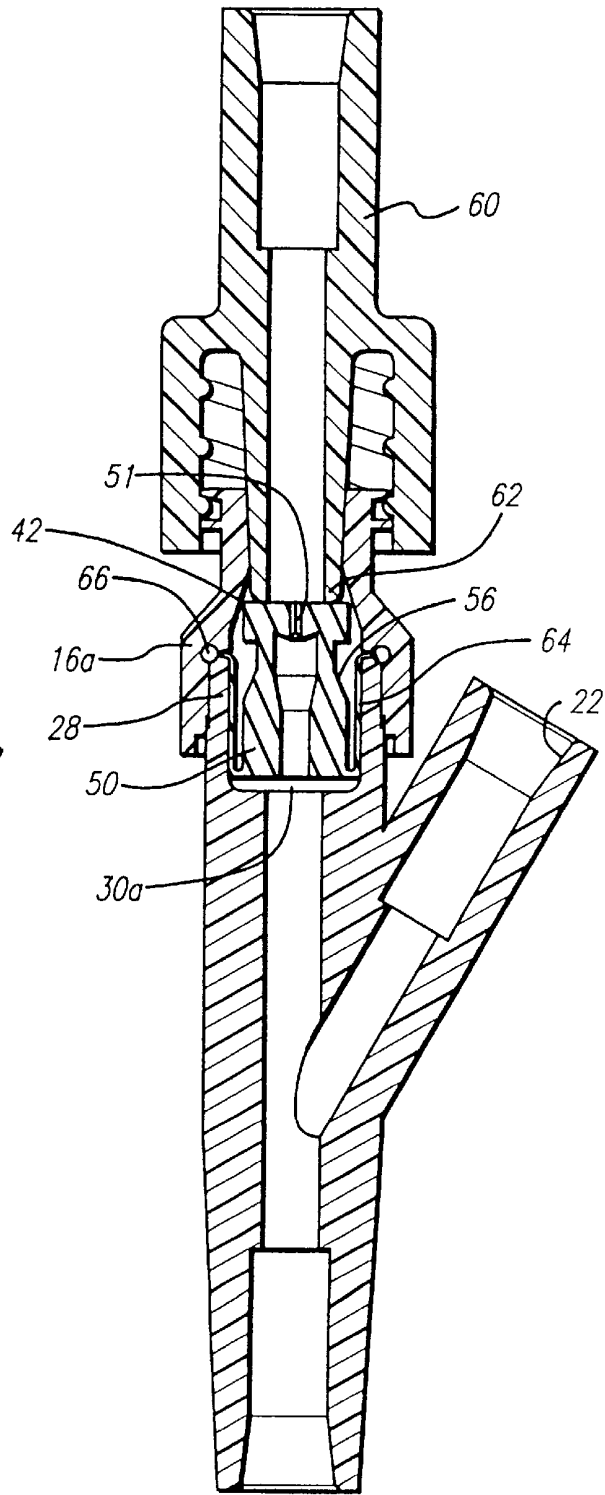
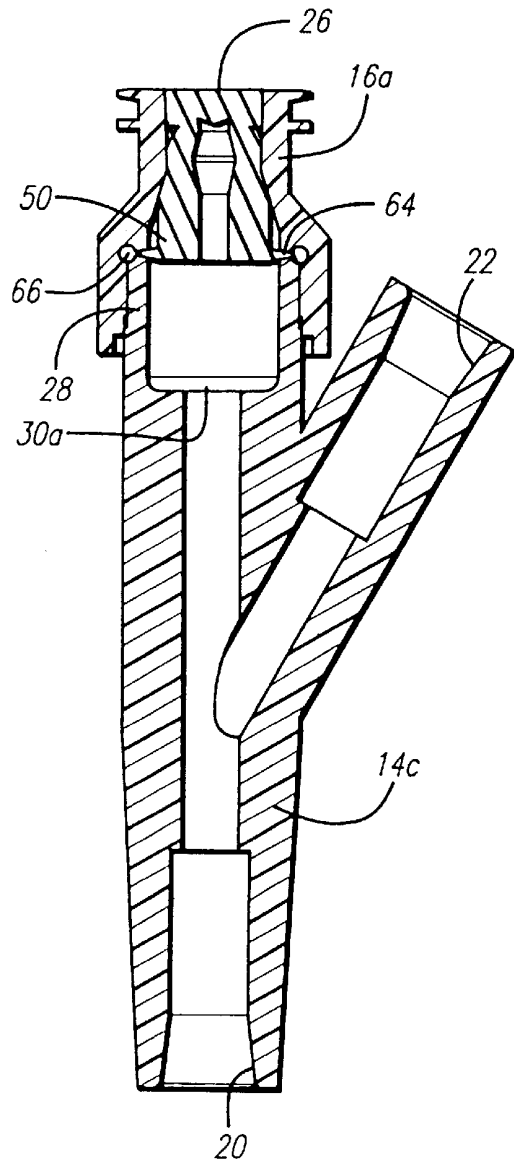
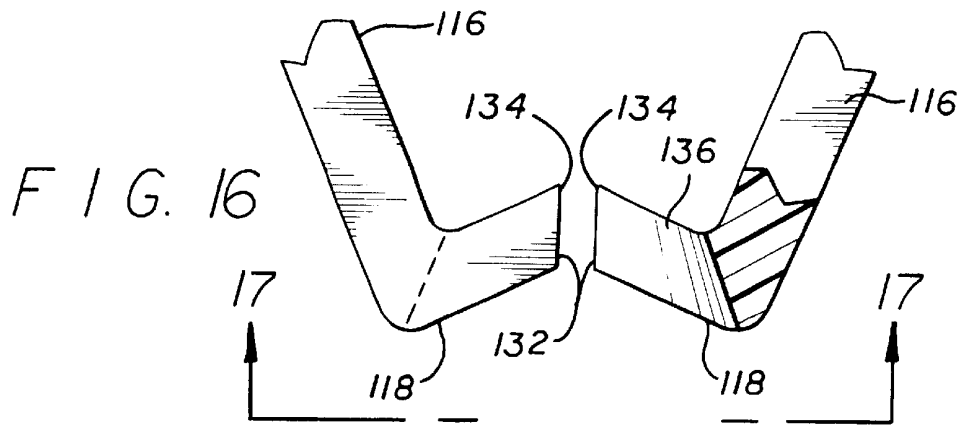
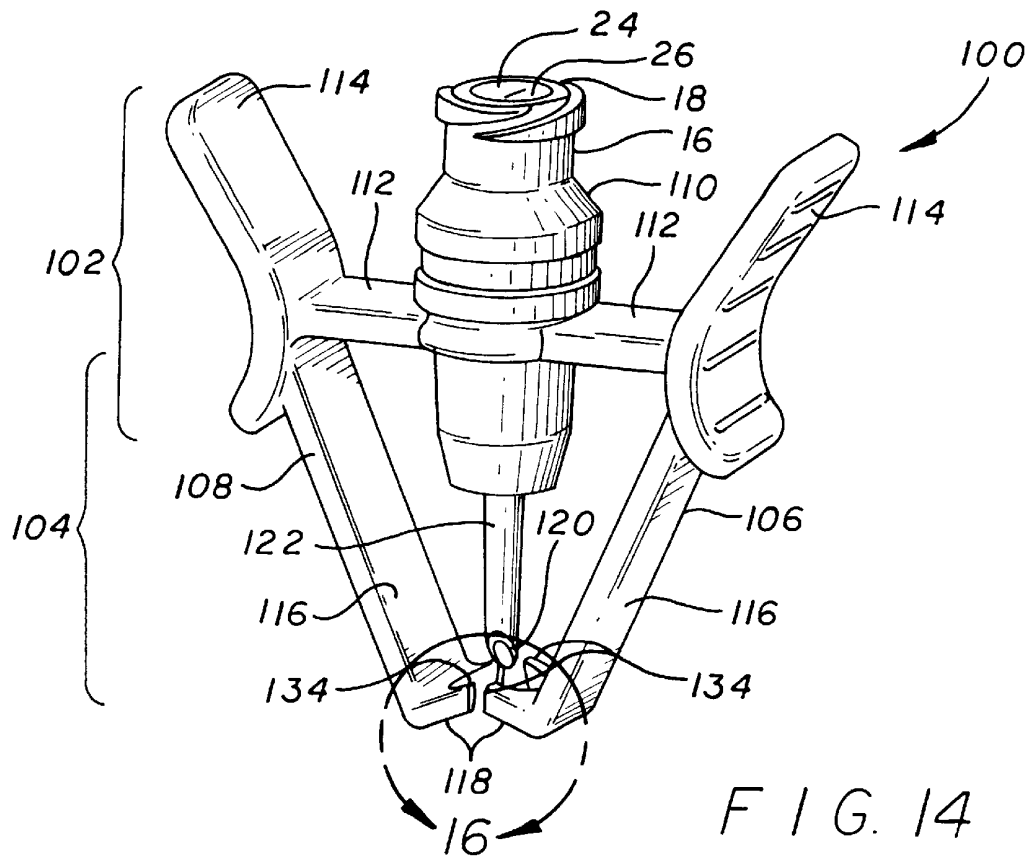

FIG. 11b

FIG. 13

FIG. 12







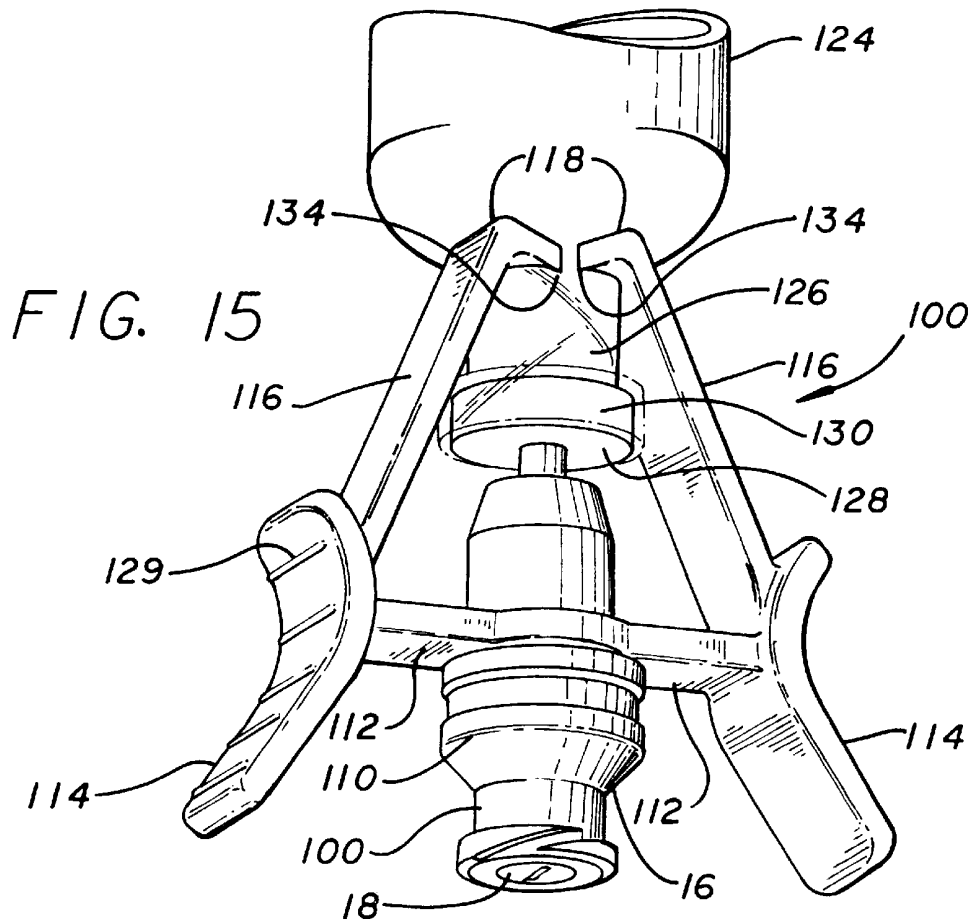

FIG. 17

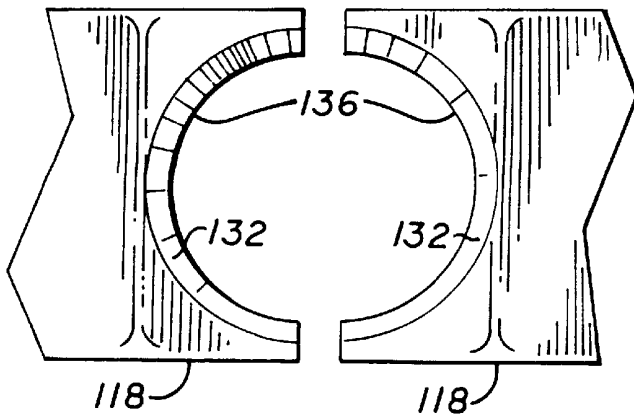
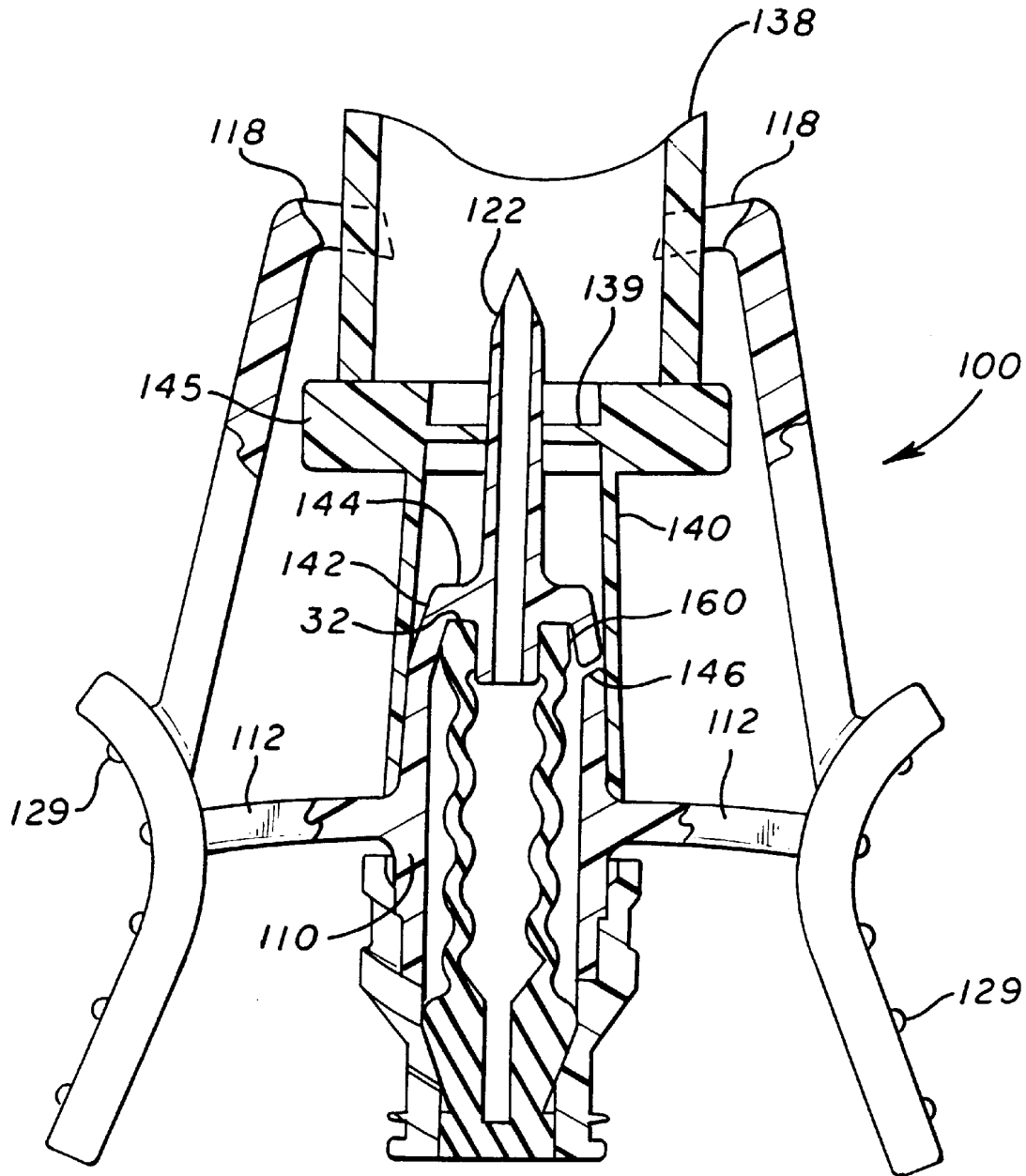
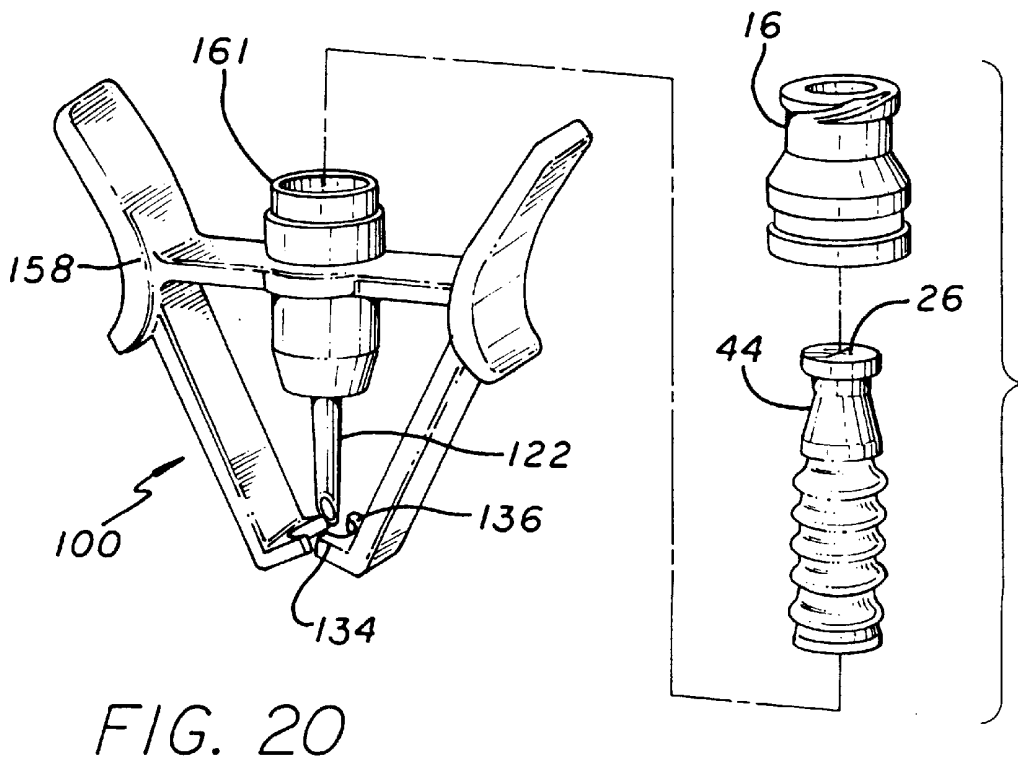
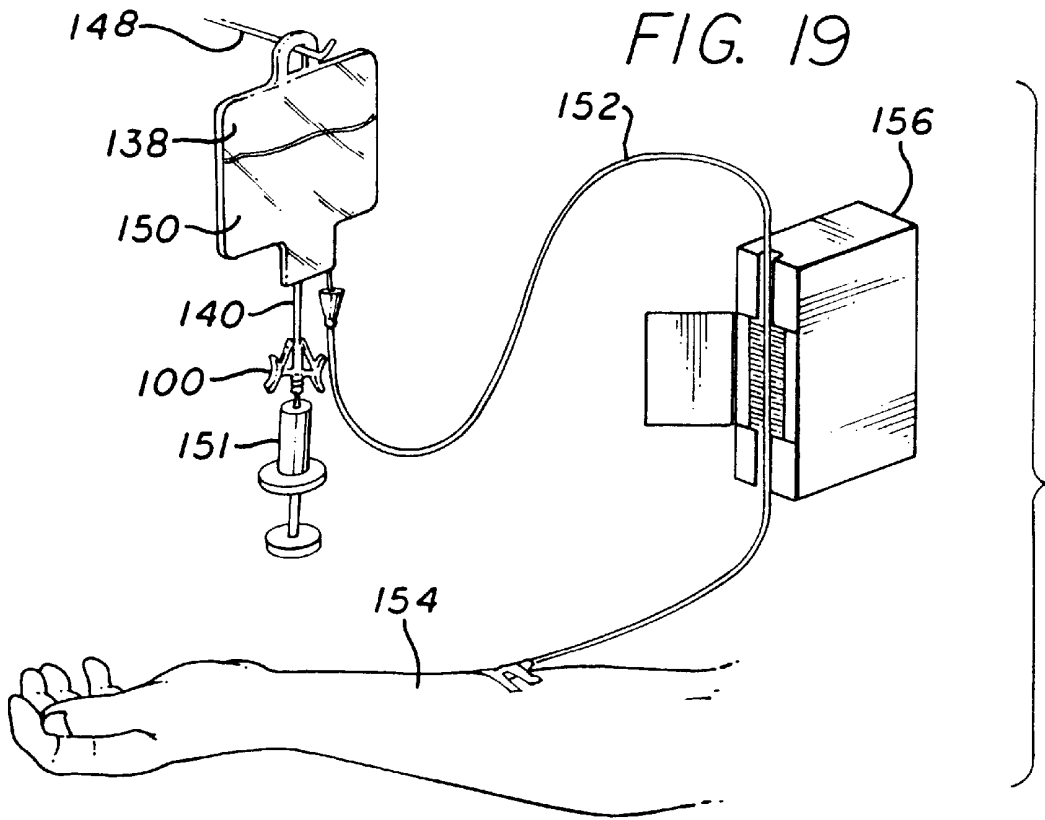

FIG. 18





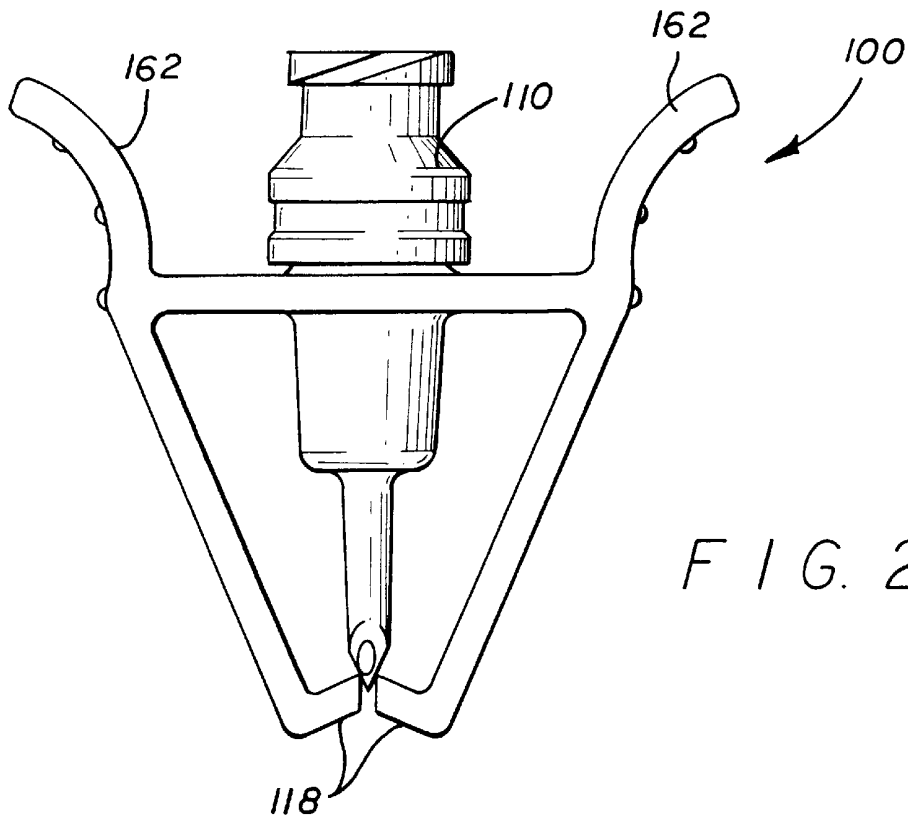

FIG. 21

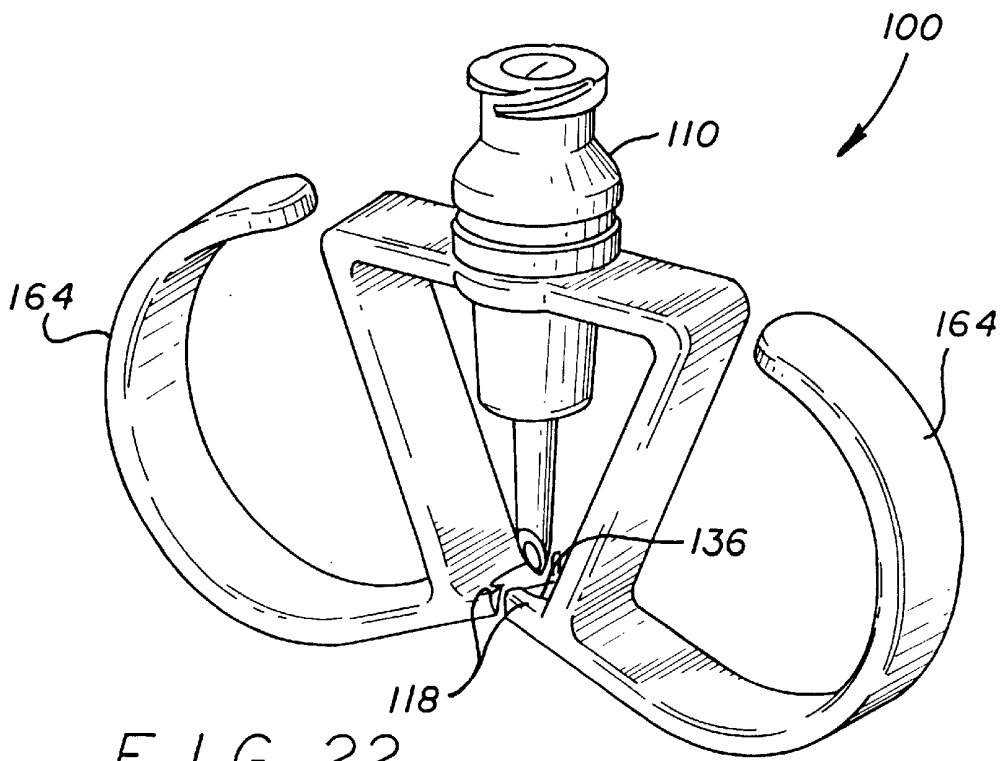

FIG. 22

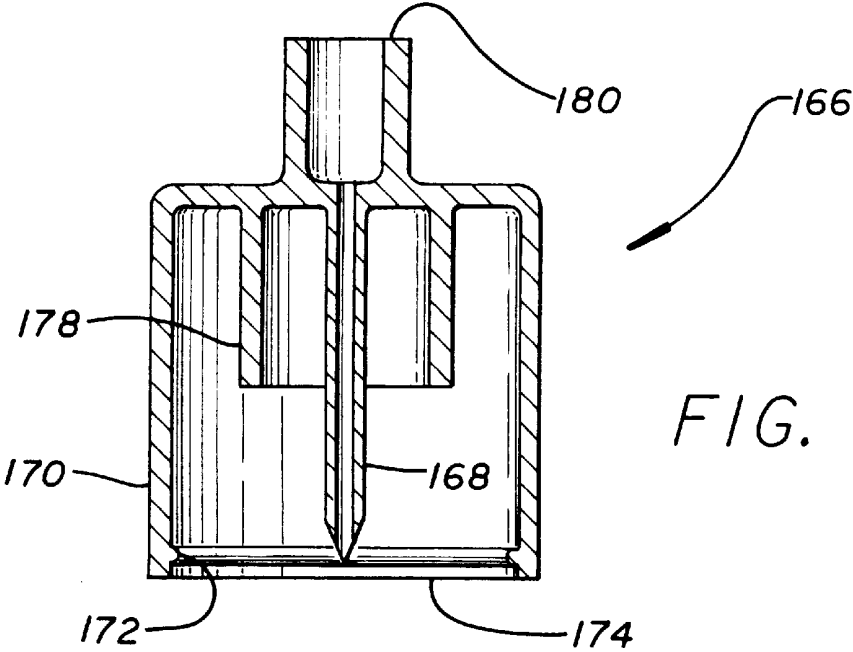

FIG. 23

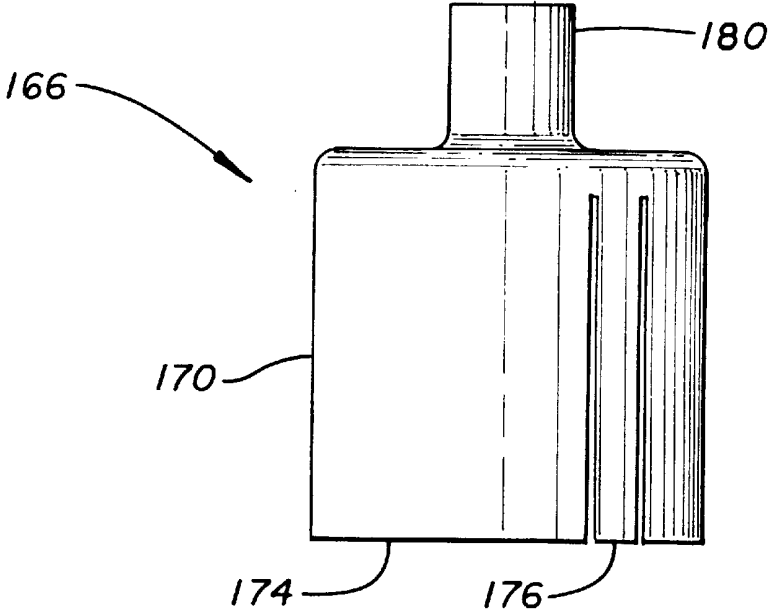

FIG. 24

## MEDICAL ADAPTER HAVING NEEDLELESS VALVE AND SHARPENED CANNULA

This is a continuation of application Ser. No. 08/794,404 filed Feb. 2, 1997, now U.S. Pat. No. 5,839,715, which is a continuation-in-part of application Ser. No. 08/705,062, filed Aug. 29, 1996, now U.S. Pat. No. 5,676,346, which is a continuation of Ser. No. 08/442,025, filed on May 16, 1995, abandoned.

### BACKGROUND

The invention relates generally to connectors of the type used in the handling and administration of parenteral fluids, and more particularly, to an adapter having both a valve mechanism for enabling a fluid interconnection to be made therewith without the use of a sharp cannula, and a sharpened cannula for interconnecting with other devices for fluid communication.

Injection sites for injecting fluid into or removing fluid from a system, such as a solution bag, a Y-site, blood tube, fluid bottle, or drug vial, are well known and widely used. Conventional injection sites generally involve a pierceable septum formed of an elastomeric material such as latex rubber or the like, captured in an access port. A sharp cannula is inserted into the access port piercing the septum to position the distal, open end of the cannula past the septum to make fluid connection with the interior of the access port. Upon withdrawal of the sharp cannula, the elastomeric septum reseals itself thus maintaining a sterile environment within the housing of the injection site. The outer surface of the septum of the injection site is wiped with an antiseptic before each use to prevent septic agents from being drawn into the access port by the piercing movement of the needle.

Due to the large number of devices available today that have pierceable septa, there is a continuing need to provide connectors that will access these devices. However, there is a large concern over the use of sharpened cannula devices. This is due, at least in part, to concern regarding the possibility of the transmission of blood-borne diseases through accidental needle punctures of persons handling the sharp cannulas. Connectors having no sharpened surfaces are desirable because such hazard is eliminated. Consequently, more recently, connectors for accommodating the injection and withdrawal of fluids without the use of sharp cannulas have been put to use in increasing numbers.

However, some existing needleless connectors suffer from various shortcomings. For example, relatively complex configurations employing a large number of parts are difficult to manufacture and assemble. This not only increases costs but may pose problems in service. Additionally, complex systems may not be intuitive to use which may prove distracting and therefore undesirable in the typical hospital room environment.

A further concern in the design of needleless connectors is the order of events in which the connection is made. For example, allowing fluid to escape or air to enter during interconnection due to the female connector being opened before the male connector is sufficiently seated is undesirable.

Additionally, some existing connectors accommodate a relatively large interior fluid volume requiring the injection of a commensurately large volume of fluid just to fill and prime the connector. If not taken into account, this fluid volume can detract from the volume of medicament injected into the patient and may be clinically significant. An incon-

venient separate flushing procedure may be required in low dose injections or in the injection of unstable medicines due to this relatively large interior volume. Moreover, relatively complex geometries and the use of springs and the like in the wetted portion of the connector interior may give rise to "dead spaces" where fluid tends to linger due to poor flushing. Dead spaces give rise to problems similar to those occasioned by large interior volumes, again resulting in the inconvenient requirement of flushing.

Where metal components, such as metallic springs, are used in connectors, the metal components can interfere with magnetic resonance imaging used in hospitals. A further difficulty with the use of coiled metallic springs is the care that must be taken during manufacture. Allowing coiled springs to come into contact with each other while awaiting assembly into the valves may result in the springs becoming entangled with each other necessitating further handling before they can be installed.

Furthermore, it is desirable that needleless connectors be configured so that they can be easily cleaned by an antiseptic wipe, or otherwise sterilized, prior to making a connection. All exterior surfaces that may be involved in the transmission of fluid should be readily available for cleaning prior to the connection being made. Some prior connectors have a small rift or fissure defined by a clearance between parts. Such a feature is difficult and inconvenient to clean in attempting to sterilize a connector. Alternatively, connectors requiring cap to maintain a sterile connection port prior to use are undesirable because the extra steps involved in removing and replacing a cap are inconvenient, while the manufacture of the cap adds expense.

The ability to accommodate a high fluid flow rate is also desirable in a needleless connector. Physicians in certain situations order the administration of medicaments at high-flow rates. Some prior connectors have restrictive geometries that limit their flow capacity such that administering fluids at high rates is impossible. The use of tortuous flow paths through a connector or multiple openings through a movable valve device through which the fluid must flow can result in a reduction of the maximum rated flow rate for the connector. With some restrictive geometries, higher flow rate requirements may not be possible under gravity head flow conditions and a positive pressure pump may be needed. Such connectors would be undesirable where pumps are not available and the usefulness of such connectors would be severely limited. The increase of flow rate capability and elimination of the tortuous fluid path can also facilitate priming of the connector and reduce potential blood hemolysis.

In addition, the performance of connectors incorporated into IV administration sets and used to allow automatic piggyback administration of medicaments becomes degraded when high flow rates through the connector cannot be accommodated. If high flow rates through the connector cannot be accommodated, automatic piggyback rates using infusion pumps must be limited to relatively low infusion rates. Otherwise, accidental simultaneous flow of primary fluids may occur when normal head height differentials are used between the primary and piggyback containers. Higher flow rates through the needleless connector allows higher flow rates of automatic piggyback administration without the possibility of accidental simultaneous flow of primary fluids.

A further consideration in the design of a connector is its compatibility with other connectors. In those cases where a cannula is mounted internally in a needleless connector to

slide inside the fluid port of a male connector inserted into the needleless connector to establish the flow path, the outer diameter of that cannula must be closely controlled so that it can successfully mate with a wide range of male connectors. Making it too large may result in interference with certain male connectors thus rendering them unusable with the needleless connector. However, making the outer diameter of the cannula too small results in reduced fluid flow rates through the cannula.

Additionally, the internal cannula in the connector can damage the valve itself. In particular, the cannula can pierce, cut, or tear a rubber piston or septum mounted over it and damage the resealability of the valve. The cannula could also create particulate by tearing off portions of the rubber piston or septum when a male Luer is inserted into the connector. This may occur where the bore of the male Luer interferes with or is closely sized with the cannula and creates a punching action that removes a piece of the rubber septum. Consequently, it is desirable to avoid such configurations.

To accommodate both the need for continued use of pierceable septa devices and the use of blunt or needleless connectors for increased safety, there is a need for a connector that can mate with both devices. Such a connector would "adapt" the pierceable device to a needleless or blunt cannula access system. Once in place through the pierceable septum, it is desirable for the adapter to be anchored in position so that inadvertent disengagement does not occur, such as is possible when such a connector is engaged with a fluid bag suspended upside down.

A further consideration is expense. Because connectors are used in a medical environment, cleanliness is of large concern. Contamination among different fluid devices, patients, etc. must be avoided. Typically, most connectors are disposable so that after one use, they are then discarded to avoid such contamination. Of course, expense is a major concern for disposable items. Connectors should be made of fewer parts so that the parts and manufacturing expense is kept as low as possible to lessen the expense to the patient.

A further consideration is the expense to the hospital or other care-giving facility caused by having to stock numerous types of connectors. A single connector/adapter that fits all other devices would be preferable. Typically, a hospital must stock a variety of connectors to be assured of mating with various medical fluid devices. For example, a blood tube has a different opening than a solution bag and two different connectors must be stocked.

In some cases, a connector having a sharpened spike at one end and a female Luer lock fitting at the other end must be stocked. In order to adapt this connector to a needleless connection, a needleless valve must be connected with the Luer fitting, thus requiring the hospital to stock two components. In many cases, the sharpened spike is housed within a shroud to protect the handler from inadvertently puncturing himself or herself. The shroud is unlikely to fit all components to which a connector is needed, thus requiring the hospital to stock multiple types of sharpened spike connectors. The requirement to stock various components increases expense for the hospital. It would be desirable to stock a single connector that would mate with all medical fluid devices.

Hence, those concerned with the development of medical connectors have recognized the need for an adapter usable with both a pierceable injection site and a needleless connection system. In addition, there is a need for such a connector to have a small number of parts so that expense is reduced. Further, there is a need for an adapter that can mate

with a wide variety of medical fluid devices so that only a single adapter is needed, thus obviating the need to stock multiple connector components. There is also a recognized need for an improved needleless connector that has a relatively simple construction with a small number of parts, that avoids the entry of air when the initial connection is made, that has reduced flushing requirements, that can be easily cleaned prior to use, and that permits a relatively high fluid flow rate. The present invention fulfills such needs and others.

#### SUMMARY OF THE INVENTION

Briefly, and in general terms, the invention is directed to a medical adapter for interconnecting a pierceable site with a male fluid connector, comprising a body having a first and a second end, a needleless site located at the first end of the body, having a fluid flow port, a sharpened cannula located at the second end of the body, the cannula having a sharpened tip, an internal fluid channel interconnecting the fluid flow port of the needleless site with the sharpened cannula so that fluid may flow between the two, a first clip arm mounted to the body, the first clip arm extending to the tip of the sharpened cannula and having a distal end, and a claw at the distal end of the first clip arm facing in the direction of the sharpened cannula and protecting the sharpened tip. In another aspect, the adapter further comprises a spring connected to the first clip arm to urge the distal end of the first clip arm toward the sharpened tip of the cannula. In a more detailed aspect, the spring comprises a resilient connecting link attached between the first clip arm and the body. In a further aspect, the claw comprises a sharpened point facing the sharpened cannula.

In further aspects, the adapter comprises a second clip arm mounted to the body opposite the first arm, the second clip arm extending to the tip of the sharpened cannula and having a distal end with a claw at the distal end of the second clip arm facing in the direction of the sharpened cannula protecting the sharpened cannula. Each claw comprises a sharpened surface and two points facing the sharpened cannula. Each claw also comprises a notch facing in the direction of the sharpened cannula.

Additionally, the adapter further comprises a handle mounted to each clip arm such that applying force to the handle will cause the claw of the clip arm to move away from the sharpened cannula tip. In another aspect, the handle is located so that applying pressure to the handle in a direction toward the adapter body will cause the claw to move away from the sharpened cannula tip. In a different aspect, the handle is located so that applying pressure to the handle in a direction away from the adapter body will cause the claw to move away from the sharpened cannula tip.

In additional aspects, the lengths of the clip arms and the claws and the angle of the claws to the respective clip arms are selected so that the claws protect the sharpened tip of the cannula to prevent the sharpened tip from piercing an operator of the adapter unless the arms and claws are moved away from the sharpened tip. The lengths of the sharpened cannula and the clip arms are selected also so that the adapter will connect with various fluid devices of different sizes. The sharpened cannula length is selected to be longer than the thickest membrane to be pierced. The arms are mounted far enough away from the body of the adapter so they will not interfere with the sharpened cannula mating with devices of different sizes.

In a more detailed aspect, the body of the adapter comprises a sealing portion that has a size selected to closely fit

with injection site tubing of a device to form a fluid-tight seal when engaged with the device.

In yet a further aspect, an adapter is provided having a protected, sharpened cannula at one end and a female connector at the other end for adapting a pierceable site to a male fluid connector while providing protection for the sharpened cannula to avoid punctures of an operator of the adapter. A plurality of protective shrouds are disposed about the sharpened cannula, with at least one shroud having a length equal to or greater than the sharpened cannula. The plurality of shrouds are concentric with the axis of the sharpened cannula and have different diameters. One shroud has a diameter selected to closely receive an elastomeric membrane of a device, such as the injection site of a solution bag, for a fluid-tight seal.

These and other features and advantages of the present invention will become apparent from the following detailed description of preferred embodiments which, taken in conjunction with the accompanying drawings, illustrate by way of example the principles of the invention.

#### BRIEF DESCRIPTION OF THE DRAWINGS

FIG. 1 is a perspective view of a connector incorporating principles of the present invention;

FIG. 2 is an enlarged cross-sectional view of the connector shown in FIG. 1 in its closed position;

FIG. 3 is an enlarged cross-sectional view of the connector shown in FIG. 2 with a male connector inserted in the connector's connection port thereby moving the piston of the connector to its open position;

FIG. 4 is a cross-sectional view of an alternative embodiment of a connector incorporating principles of the invention and showing it in its closed position;

FIG. 5 is a cross-sectional view of the connector shown in FIG. 4 with a male connector inserted in the connector's connection port thereby moving the piston of the connector to its open position;

FIG. 6 is a further enlarged cross-sectional view of the Luer adapter component of the connector shown in FIGS. 1 through 5;

FIGS. 7a and 7b are further enlarged cross-sectional side and top views of the piston component of the connector shown in FIG. 2 with the views rotated 90° from each other;

FIG. 8a is a cross-sectional view of an alternative embodiment of a connector incorporating principles of the invention;

FIG. 8b is a further enlarged cross-sectional view of a portion of the connector of FIG. 8a showing the piston with an inserted male connector;

FIG. 9 is a greatly enlarged cross-sectional view of an alternative embodiment piston head;

FIGS. 10a through 10d present different configurations of a piston element usable in a connector of the present invention;

FIGS. 11a and 11b illustrate cross-sectional views of an alternative embodiment of a connector incorporating principles of the present invention in which a center post is included. FIG. 11b presents the view of FIG. 11a taken along lines 11b—11b;

FIG. 12 is an enlarged cross-sectional view of another alternative embodiment of a connector in accordance with aspects of the invention;

FIG. 13 is an enlarged cross-sectional view of the connector shown in FIG. 12 with a male connector inserted for fluid communication

FIG. 14 is a perspective view of a medical adapter having a needleless valve access port and a sharpened cannula in accordance with aspects of the invention;

FIG. 15 is a view of the medical adapter of FIG. 14 showing the sharpened access cannula piercing the rubber septum of a drug vial;

FIG. 16 is a detailed view of the claws of the medical adapter of FIG. 14 along lines 16;

FIG. 17 is a detailed end view of the claws from a different angle along lines 17—17 of FIG. 16;

FIG. 18 is a partial cross-section view of the medical adapter of FIG. 14 showing the sharpened access cannula piercing the plastic membrane of a solution bag and forming a fluid seal with the injection port tubing of the bag;

FIG. 19 is a view of an application of the adapter of FIG. 14 with a fluid solution bag and a syringe, showing also a fluid administration set used with an infusion pump and a patient;

FIG. 20 is an exploded view of the medical adapter of FIG. 14;

FIG. 21 is the adapter of FIG. 14 with an alternate handle arrangement;

FIG. 22 is also the adapter of FIG. 14 with yet another alternate handle arrangement;

FIG. 23 is a cross-section diagram of an adapter having a sharpened cannula at one end and a female connection at the other end for receiving a male fluid connector, with a plurality of shrouds surrounding the sharpened cannula and a raised ridge to assist in holding the adapter in place; and

FIG. 24 is a diagram of the adapter of FIG. 23 showing a spring arm formed in a shroud for gripping a device to which the sharpened cannula would be engaged.

#### DETAILED DESCRIPTION OF PREFERRED EMBODIMENTS

Referring now to the drawings in which like numerals refer to like or corresponding elements among the several figures, there is illustrated in FIGS. 1 through 3 a Y-connector incorporating a needleless valve embodying the principles of the present invention. This particular connector configuration was selected for illustration purposes only as the subject needleless valve can be embodied in any of a variety of connectors including, but not limited to, J-loops, T-connectors, Tri-connectors, PRN adapters, Luer-locks, slip Luers, tubing engagement devices, access pins, and others.

As is shown in FIG. 1, the Y-connector 12 comprises a housing 14 terminating in an exit port 20 and having a Y-branch 21 with a Y-branch port 22. This particular embodiment also comprises a Luer adapter 16 forming a part of the housing and that adapter includes a connection port 18. The adapter is configured to receive all ANSI standard male Luer fittings, as well as other blunt cannulas or fluid conduit devices. In its unaccessed state or closed position, a piston head 24 located internally to the housing is flush with the surrounding connection port 18 and has a tightly closed orifice 26 at its center.

FIG. 2 shows in enlarged cross-section the Y-connector of FIG. 1 with the needleless valve in its closed position. The Y-branch 21 leads to the Y-branch port 22 and the distal section 19 of the housing 14 extends between the Y-branch and the exit port 20. The housing 14 includes a tubular section 28 having a circular cross-section, an exit orifice 30 at its base 31, a support tube 29 extending upwardly from the base, and a groove 32 formed in the base surrounding the



support tube. The exterior surface of the tubular section **28** near its proximal end is stepped slightly inwardly **34** to receive the Luer adapter **16** thereover and provide ultrasonic weld geometry. Alternatively, the adapter and the housing may be joined by a spin weld, snap fit, by bonding, or by other means.

FIG. **2** additionally shows the piston element **44** in place within the bore **33** of the tubular section **28** captured between the Luer adapter **16** and the base **31**. The piston element **44** includes a total of four bellows. The alternative embodiment illustrated in FIGS. **4** and **5** is similar to the embodiment shown in FIGS. **2** and **3**, with the exception that the support tube **29** has been deleted, and the piston element **44a** has a total of five bellows of shallower angle.

As is illustrated in FIG. **6**, the interior of the Luer adapter **16** has sections of various diameters. The section directly adjacent the connection port **18** comprises a standard ANSI Luer taper section **38** that incorporates a very slight inward taper. The center section **40** has a substantially larger diameter and is separated from the taper section **38** by the tapered ramp/lock section **42**. Additionally, the inner diameter of the center section **40** is slightly larger than the inner diameter of the tubular section **28** of the body **14** for reasons discussed below. Finally, the Luer adapter **16** includes a skirt **36** that is dimensioned to fit over the stepped proximal end **34** of the tubular section **28** to provide ultrasonic weld geometry. The adapter **16** may be molded of a material containing a phosphorescent colorant to render the connector visible in a darkened room.

As is generally shown in FIGS. **2** through **5**, a resiliently deformable piston element **44** and **44a** is captured between the base **31** of the tubular section **28** and the Luer adapter **16** in the bore **33** of the housing **14**. While the details of its structure vary slightly from embodiment to embodiment, the views of element **44a** shown in FIGS. **7a** and **7b** serve to illustrate many of the common features. The piston element's structure **44a** which is molded in its entirety of rubber in this embodiment generally includes a piston **46** and a compressible section **48**. The piston **46**, in turn, includes a piston head **24** that is elliptical in cross-section and a thick taper-lock portion **50** that is circular in cross-section. A marquise-shaped bore **51** is formed along the longitudinal axis of the piston head **24** and terminates in an orifice **26** at its proximal end and a taper lip seal **59** at its distal end. The taper lip seal **59** comprises a pair of lips **54** that extend from opposed sides of the bore's sides. The lips comprise conical sections that extend from the bore's sides to function as a seal.

As is apparent when comparing FIGS. **7a** and **7b**, the marquise-shaped bore **51** is oriented such that its major axis **53** is perpendicular to the major axis **55** of the elliptically-shaped piston head. Additionally, the transitional section **57** between the piston head **24** and the taper lock portion **50** is elliptical and conical in shape wherein the major axis of such ellipse is parallel to the major axis **55** of the piston head and perpendicular to the major axis **53** of the bore **51**. This geometry further assists in naturally biasing the marquise-shaped bore into its open position. This elliptical shape creates an outward force parallel to the major axis of the elliptical shaped piston head and an inward force parallel to that same axis. The inward force tends to compress the piston in a direction perpendicular to its major axis and thus tends to pull the marquise-shaped bore open when a male Luer applies force to the top of the piston moving the piston into the center section **40** of the adapter **16**.

The taper-lock portion **50** of the piston element **44** is fairly thick in order to prevent it from being compressed. This

thicker section helps to hold the piston in the valve at higher internal pressures and also acts as a divider between the spring action below and the opening and closing of the marquise-shaped bore above. Although the piston element **44** is seated in the base **31** of the housing tightly, extreme internal pressures may provide a substantial force to push the piston element **44** out of the housing **14** thereby destroying its integrity. This thickened portion **50** of the piston element provides added assurance that it will not compress under such internal forces and will hold the piston in position in the housing.

FIGS. **8a** and **8b** illustrate an alternative embodiment wherein the inner diameter of the tubular section **28** is sufficiently reduced relative the inner diameter of the center section **40** of the adapter **16** to accommodate an annular groove **35** formed in its proximal edge. Sections of a circular groove **37** are formed on each end of the major axis **55** of the bottom of the elliptical piston head **24** to provide hooks **25**. The hooks are configured so as to engage the groove **35** in the tubular section. Once the hooks have engaged the groove as a result of the male Luer **62** pushing the piston **24** farther into the adapter **16**, the hooks will oppose further movement of the periphery of the piston and will result in any further male Luer forces causing the bore **51** to open wider, as shown in FIG. **8b**.

FIG. **9** illustrates an alternative embodiment wherein a pair of flexible flaps **55** extend from about the bore **51** to provide a check valve **69**. This opposes the back flow of fluid while the piston element is in its closed state.

Returning now to FIGS. **7a** and **7b**, the bore **51**, in conjunction with the hollow interior of the taper lock section **50** and the hollow interior of the compressible section **48**, forms a fluid path through the entire piston element **44**. The compressible section **48** may comprise an accorded configuration as shown in FIGS. **2-5**, **7a**, **7b**, and **8a** or, alternatively, an annularly or helically ribbed structure that similarly allows for the controlled collapse of the structure along its longitudinal axis to generate a restoring force. Some alternative embodiments are illustrated in FIGS. **10a** through **10d** and show possible variations in the number, size, and configuration of the ribs or bellows. Different shapes of the piston element may be used to improve flow rate, activation force, spring return rate, sealing, piston retention, and acceptance of blunt cannulas. The piston geometry variations could also improve the valve function with fluids that easily solidify by removing internal annular grooves and pinch point areas. Modifications include changing the number of bellows, ribs, wall thickness, height, diameter, durometer, color, and geometry. Pinch point areas are formed from the accorded folds that come together upon compression of the piston and could, under certain conditions, trap solidified fluids to interfere with the compression of the piston.

In particular, FIG. **10a** shows a compressible section having five bellows as per FIGS. **4**, **5**, **7**, and **8** which require a reduced activation force. FIG. **10b** shows a compressible section having an external ribbed structure wherein the compressed shape has no pinch points. FIG. **10c** shows the compressible section of the piston element with straight walls to increase activation force and reduce pinch points. FIG. **10d** shows a compressible section which provides a smooth interior surface upon compression to increase the flow rate.

Returning again to FIGS. **2,3**, **7a**, and **7b**, the distal end **45** of the compressible section **48** is received in the groove **32** in the base **31** of the tubular section **28** to form a tight seal

about the support tube **29** and the exit orifice **30**. The piston element is lubricated with FDA approved silicone oil to facilitate movement of the piston within the connector and to prevent the bore **51** through the piston head **24** from being sealed closed during sterilization.

In the alternate embodiments illustrated in FIGS. **11a** and **11b** a support structure, in the form of a flattened post **63**, has been added to the interior of the tubular section **28** so as to project into the compressible section **48** of the piston **46**. The post has a rounded tip **61** that extends into the bore **51** of the piston element **24** upon depression of the piston **44** to assist in its opening. Clearance between the post's tip **61** and the pointed ends of the marquis-shaped bore **51** facilitates flow thereby, while clearance between the thinner dimension of the flattened post **63** and the interior surface of the collapsible section **48** allows for the flow of fluid into the exit orifice **30**.

FIGS. **12** and **13** illustrate a further alternative embodiment wherein an extension spring in the form of a diaphragm **64** serves to bias the piston **46** into its closed position, rather than the compression spring approach shown in the other figures. The diaphragm **64** extends from the base of the taper lock section **50** and has an annular bead **66** formed about its periphery. Such bead is captured between the Luer adapter **16** and the proximal edge of the tubular section **28**. Grooves are formed in these respective elements to ensure a positive grasp of the bead element **66**. The position of the bead **66** relative its point of attachment to the taper lock section **50**, and the sizing of the diaphragm **64** ensure that the diaphragm is pre-loaded such that it biases the tapered shoulder **56** of the piston **46** into contact with the taper lock section **42** of the adapter **16**.

Turning now to a more detailed discussion of the operation of the valve shown in the various figures, the dimensions of the elliptical piston head **24** and the marquis-shaped bore **51** are selected such that when the head is constrained into the circular interior of the ANSI Luer taper section **38** of the Luer adapter **16**, the bore is completely collapsed to tightly close off the orifice **26** and cause the adjacent lips **54** of the taper lip seal **59** to abut one another. The tapered shoulder **56** of the taper lock section **50** contacts the ramp/lock section **42** of the adapter **16** and prevents the top of the piston head **24** from extending beyond the connection port **18**. The internal diameter of the center section **40** of the Luer adapter **16** is selected such that the piston head **24** is free to assume its elliptical shape when positioned therein. This, in turn, allows the bore **51** to reassume its natural marquis-shape thereby opening a fluid path through the piston and the connector.

Referring now to the embodiments shown in FIGS. **2–11**, the needleless connector is initially in its unaccessed state or closed position as shown in FIG. **2**, **4**, **11a**, and **11b**. The compressible section **48** is pre-loaded and causes the piston head **24** to be biased into the ANSI Luer taper section **38** (FIG. **6**) of the Luer adapter **16**. The shoulder **56** of the taper-lock section **50** contacts the tapered ramp/lock section **42** of the adapter **16** and prevents the top of the piston head **24** from extending beyond the connection orifice **18** to form a smooth and flush surface. The bore **51** throughout the piston head **24** is tightly squeezed shut by virtue of the normally elliptically shaped piston head being constrained into the circular cross-section of the ANSI Luer taper section **38**. The sharp pointed ends of the marquis-shaped bore facilitate a tight seal upon compression of the bore along its minor axis by compression of the piston head **24** along its major axis. The taper lips **54** of the taper lip seal **59** or, alternatively, the flexible flaps **55** of the check valve **69**

further ensure that the bore **51** remains sealed even when subjected to substantial internal pressures. The diaphragm element **64** employed in the alternative embodiment shown in FIGS. **12** and **13** similarly serves to bias the piston head **24** into the ANSI Luer taper section of adapter **16**.

Just prior to accessing the connector, the piston head **24** and the edge of the connection port **18** are cleaned by, for example, passing a sterilizing swipe over the smooth surface. The absence of ridges, grooves, gaps, or protrusions ensure that proper cleanliness is achieved. The connector is then ready to be accessed by a standard male Luer with or without a Luer lock.

As the male Luer tip **62** of the male Luer connector **60** (FIGS. **3**, **5**, **8**, and **13**) is brought into contact with the top surface of the rubber piston head **24**, a seal is formed to preclude the passage of liquidator air there between. The application of sufficient pressure causes the compressible section **48** of the piston element **44** to compress or, alternatively, diaphragm **64** to stretch, and the piston head **24** to be moved out of the ANSI Luer taper section **38** and into the center section **40** (FIG. **6**). As the piston head clears the tapered ramp/stop section **42** and is moved into the center section **40**, its larger internal diameter allows the piston head to assume its naturally elliptical open shape. This, in turn, allows the bore **51** to assume its natural marquis-shape thereby opening a fluid path through the piston head. Continued pressure by the male Luer causes the piston head to be advanced into the tubular section **28** of the main body **14**.

In FIGS. **8a** and **8b**, the slightly reduced inner diameter of the tubular section **28** relative to the diameter of the center section **40** of the adapter **16** serves to further enlarge the orifice **26** of the bore **51** by forcing rubber material up around the outside of the male tip **60**. The hooks **25** formed in the bottom edge of the taper lock section **50** engage an annular groove **35** to positively pull the bore **51** open. The center section **40** of the Luer adapter **16** may be formed to have an elliptical shape wherein its minor axis is sized slightly smaller than the minor axis of the piston head **24**. This serves to compress the piston head along its minor axis further ensuring that the bore attains its fully opened shape. In the alternative embodiment shown in FIGS. **11a** and **11b**, slight penetration of the rounded tip **61** of the post **63** into the bore **51** positively ensures the opening of the bore. The fact that the tip is rounded and of relatively small diameter prevents it from damaging the piston. It has been found that the embodiment of the post **63** shown does not cut, tear, or cause a punching action on the piston when the piston is moved into contact with the post **63**.

In this position, the connector is fully accessed to provide a short, straight, unobstructed fluid path through the connector. At no time does fluid flow about the outside of the piston element on its way through the connector. A "residual" volume, i.e., the volume between the male Luer and the exit orifice, of as little as 0.04 ml is attainable. Air leakage, or the entry of contamination, as well as the escape of fluid from the device, is precluded at all times.

In the embodiment shown in FIGS. **2** and **3** and the alternative embodiment shown in FIGS. **11a**, **11b**, the support tube **29**, and the center post **63**, respectively, serve to prevent the compressible section **48** from buckling and closing off the fluid path. The flattened cross-sectional shape of the post **63** ensures adequate clearance adjacent the compressed accorded section **48** to provide for flow at all times. In the embodiment shown in FIG. **3**, fluid is directed through the center of the support tube **29**.

As the male Luer is withdrawn, the biasing force generated by the compressible section **48** of the piston element **44**,

or the stretchable diaphragm **64** of the alternative embodiment shown in FIGS. **12** and **13**, maintains contact between the piston head **24** and the male Luer tip **62**. The slightly larger diameter of the center section **40** of the Luer adapter **16** (FIG. **6**) relative to the tubular section **28** causes the piston taper-lock section **50** to freely move into position with the shoulder **56** (FIG. **7a**) abutting the ramp/lock section **42** (FIG. **6**). Simultaneously, the elliptical piston head **24** is guided into the ANSI Luer taper section **38** by the tapered ramp/lock section **42** where it is once again forced into the constrained circular shape of the ANSI Luer taper section to close off the bore **51** and reestablish a positive seal. A similar operation occurs with the embodiment shown in FIGS. **12** and **13**.

Referring now to FIG. **14**, there is shown a medical adapter **100** having a needleless valve section **102** and a sharpened cannula section **104**. Also included are two spring clips **106** and **108** on opposite sides of a generally tubular-shaped body member **110**. Each spring clip **106** and **108** includes a spring **112**, a handle **114**, an arm **116**, and a claw section **118**. At rest, as shown in FIG. **14**, the springs **112** are approximately perpendicular to the body **110** and the claws **118** are almost touching. In other embodiments, the springs may be mounted such that they have different angles in relation to the body. The arms **116** and the claws **118** are configured so that when the adapter **100** is not installed through a pierceable membrane for fluid flow, the arms and claws cover the sharpened point **120** of the cannula **122** to reduce the likelihood of inadvertent punctures when handling.

The needleless valve section **102** of the adapter **100** includes the piston head **24** containing an opening **26** (also shown in FIG. **20**), as shown and described previously.

Shown in FIG. **15** is an application of the adapter of FIG. **14** to a drug vial **124**. The arms **116** of the adapter are located on either side of the neck **126** of the bottle and the spike **122** has pierced the elastomeric septum **128**. In spreading apart the arms, the operator would press inward on both handles **114** until the claws **118** clear the flange **130** of the bottle opening, and then pierce the septum **128** with the spike, as shown. The handles include raised ridges **129** in this embodiment, to assist the operator in pressing the handles inward. Because pressing the handles **114** inward causes the springs **112** to bend, they will tend to straighten themselves thereby urging the claws **118** toward each other and maintaining the claws **118** in contact with the bottle neck **126**. The claws will therefore not be able to be pulled past the flange **130** of the vial thereby preventing the spike from disengaging from the septum **128** of the bottle. Additionally, the friction of the spike in the septum **128** tends to keep the adapter **100** in place. A needleless connector, such as a male Luer taper fitting, may be inserted into the needleless connection port **18** to open the valve created by the piston **44** (not shown) and permit fluid flow. Fluid may be conducted into the vial **124**, for mixing purposes for example, and may be conducted out of the vial, into a patient for example. The needleless connector port in FIG. **15** also has a male Luer fitting.

Referring now to FIGS. **16** and **17**, detail of the claws **118** can be observed. The claws are located at an angle to the arms **116** which in this case is  $90^\circ$ . Other angles may be used. A bevel **132** is formed on each claw to result in a sharp interior edge and two points **134** (also seen in FIG. **14**). Additionally, as is more apparent in FIG. **17**, a circular notch **136** is formed in each claw. Because the radius of the notch would be correct for only one neck size, its primary purpose is to result in the two sharp points **134** on each claw **118** for

engaging a variety of devices to hold the connector in place. Secondly however, the notch may provide a fit with a rounded device of the proper size for even greater surface contact between the claw and the device.

Turning now to FIG. **18** which shows a cross section of certain elements, the adapter **100** has been engaged with the injection port of a fluid bag. The injection site of the fluid bag comprises a thin plastic membrane **139** that the sharpened cannula **122** has penetrated for fluid communication with the interior of the bag and any contents therein. The claws **118** have engaged the tubing **138** of the bag due to the action of the springs **112**. The fluid bag includes a sealing tubing **140** forming a part of the opening of the bag. The sealing tubing **140** has been engaged by the adapter **100** in a fluid-tight relationship. The body **110** of the adapter includes a taper **142** between the base **144** of the sharpened cannula **122**, which has a larger radius than the cannula, and the sealing portion **146** of the body **110**. The sealing portion **146** has a size selected to provide a tight fit between it and the inner diameter of the sealing tubing **140** of the bag for a fluid-tight seal. Any fluids dripping from the pierced membrane **139** of the bag will not pass the seal created by the sealing portion **146** and the tubing **140**. Thus the adapter **100** can be left in position in the sealing tubing **140** for later use. The taper **142** on the body **110** assists in guiding the sharpened cannula **122** and the sealing portion **146** into the sealing tubing **140** of the bag for easier engagement. Typically, a twisting motion is used to insert the body **110** fully into the sealing tubing **140** to establish a fluid-tight seal.

FIG. **19** presents an application of the adapter **100** shown in FIG. **18**. The solution bag **138** is inverted and hung from a hangar **148**. The adapter **100** has been inserted and has pierced the thin membrane of the bag as shown in FIG. **18** thus establishing fluid communications with the medical fluid **150** in the bag. A syringe **151** has been inserted into the needleless valve section **102** of the adapter **100** for drawing fluid **150** from the bag or inserting fluid into the bag. The other port of the bag **138** is connected to a fluid administration set **152** that includes a sharpened cannula (not shown) piercing the bag port, tubing, and a cannula applied to a patient **154**. To control the administration of the medical fluid **150** to the patient **154**, a volumetric infusion pump **156** operates on the tubing in a process well known to those skilled in the art to accurately meter the fluid **150** to the patient. Although not clearly shown, the infusion pump in this case comprises peristaltic fingers and a pressure plate (not shown) to accurately control the flow of medical fluids through the tubing **152** to the patient.

Because the neck of the bag, which the claws **118** engage, is formed of a resilient plastic material, the sharp edge **134** of the claws achieve a grip on the bag. Additionally, there is a substantial amount of friction between the sealing portion **146** and the tubing **140** so that it is unlikely that the adapter **100** will fall out of the bag **138** due to the weight of the syringe **151**, even if full. Additionally, the configuration of the claws at an angle to the arms further resists disengagement with the bag because before the adapter **100** could drop off the bag, the claws would likely hit the flange **145** of the bag formed by the membrane **139**. The spring force will typically be large enough to prohibit the arms from moving outward on their own or in response to the weight of the syringe.

The length of the springs and the length of the arms are selected so as to successfully engage any device to which the adapter may be used. Because the springs and arms are relatively long, they will successfully engage small as well

as large devices. In select applications, the length of each may be reduced, as desired.

It should therefore be appreciated that the adapter **100** adapts the pierceable bag membrane to a needleless connection. The adapter **100** may be left in place while the bag is connected, disconnected, and reconnected to fluid administration sets **152** as required. The adapter **100** is fluid tight with the sealing tubing of the bag and contains an internal and fully integrated needleless valve **102** so that unless a connector is engaged with the adapter **100**, no fluid will flow.

FIG. **20** presents an exploded view of the adapter **100** of FIG. **14**. In this embodiment, the adapter comprises only three parts: a Luer adapter **16**; a piston **44**; and the sharpened cannula section **158**. The sharpened cannula section **158** is constructed as one piece and includes the springs, handles, arms, claws, sealing portion, taper, and sharpened cannula. The piston **44** is friction fit into the sharpened cannula section **158** as can be seen more clearly in FIG. **18**. The groove **32** is formed to have a tight fit with the piston **44** to retain the piston. For ease in assembly, a vent **160** is formed in the side wall of the sharpened cannula section **158** to allow air to escape during assembly of the tight fitting piston in the groove **32**. The proximal end **161** of the sharpened cannula section is ultrasonically welded to the Luer adapter **16** for final assembly of the adapter **100**. This small number of parts and ease in assembly results in reduced cost for the adapter **100**. In other embodiments, a larger number of parts may be used to construct the adapter. For example, the sharpened cannula **122** may be a separate part attached to the base **144**. It may be formed of a metallic substance.

Referring now to FIGS. **21** and **22**, two alternate handle designs are shown. In FIG. **21**, the handle **162** comprises only a curved segment on the needleless valve section side of the springs. The operator would press the handles **162** inward toward the body **110** to open the claws **118**. In FIG. **22**, each handle **164** comprises two curved segments located on the sharpened cannula side of the springs for receipt of the operator's fingers or thumb and fingers. The operator would pull on the handles **164** to separate the claws **118**.

Thus it will be appreciated that a versatile adapter has been disclosed. The design of the adapter is such that the sharpened cannula is protected from inadvertent punctures of operators yet can successfully be used to adapt pierceable septa to use with needleless devices. Both a sharpened cannula and a needleless connector are included in one adapter thus obviating the need for two separate devices. A restrictive, single-sized shroud is not used to protect the sharpened cannula. The protective arms in accordance with the invention move out of the way when inserting the sharpened cannula thus permitting the adapter to be used with a wide variety of devices. Thus the adapter also obviates the need to stock various sizes of connectors, as the adapter in accordance with the invention is capable of fitting numerous devices of varying sizes. For example, the adapter will successfully connect to solution bags, blood tubes, drug vials, Y-sites, and pre-slit and unslit injection sites. The length of the sharpened cannula is selected to be longer than the thickest rubber septum or membrane and the lengths of the arms and springs are selected to be long enough to fit over and around all of the above-listed devices. Because of the small number of components forming the adapter, the priming volume is significantly reduced and the dead space in the adapter, in which fluid will pool, is also significantly reduced or eliminated. This results in more fluid reaching the patient and less fluid being lost as overhead, or adapter lost fluid.

Alternate embodiments are possible, as is likely apparent to those skilled in the art. In one case, a barb or barbs may

be added to the sharpened cannula so that the sharpened cannula cannot be removed once inserted into the septum.

An alternate embodiment of a protected adapter **166** is shown in FIG. **23** and **24**. In this embodiment, a sharpened cannula **168** is disposed within a plurality of protective shrouds. In this case, the outer shroud **170** is at least as long as the sharpened cannula **168** to protect the cannula from puncturing an operator of the adapter **166**. A raised ridge **172** is formed near the open end **174** of the outer shroud **170**. The raised ridge disposed completely around the inside surface of the outer shroud assists in retaining the adapter in place over a pierceable site. As the shroud is forced over the site, the ridge will also snap over the flange of the site, for example, and will retain the adapter **166** in place.

As an alternative to the raised ridge of FIG. **23** that continues completely around the inside surface, FIG. **24** presents an embodiment where an arm **176** has been formed in the outer shroud **170** by forming two slots in the axial direction. Although not shown, a raised ridge would be formed on the inside surface of the arm **176** to function in the same way as the ridge in FIG. **23**. Because the slots forming the arm are relatively lengthy, the arm can move outward and inward in relation to the shroud **170**. Its connection to the shroud acts as a spring urging the arm **176** back to its position level with the shroud **170**.

Returning now to the cross-section view of FIG. **23**, an inner shroud **178** is concentric with the sharpened cannula **168**, as is the outer shroud, and is shorter than the outer shroud. The inner diameter of the inner shroud **178** is selected to closely fit with the elastomeric septum provided with the injection port of solution bags. Forcing the elastomeric septum into the inner shroud creates a fluid-tight seal. The sharpened cannula is long enough to pierce the plastic membrane of the injection port of a solution bag, shown in FIG. **18**, as the elastomeric septum (not shown) seals with the inner shroud. The elastomeric septum has been removed from the injection port shown in FIG. **18**.

In FIG. **23**, a female Luer fitting **180** is formed at one end of the adapter. A needleless valve may be disposed in the adapter **166** instead of only the female Luer fitting, similar to the configuration shown in FIG. **18**.

While particular forms of the invention have been illustrated and described, it will also be apparent to those skilled in the art that various modifications can be made without departing from the spirit and scope of the invention. Accordingly, it is not intended that the invention be limited except by the appended claims.

What is claimed is:

1. A valve mechanism for forming a fluid-flow path within a medical connector having a hollow housing extending between an inlet port and an exit port, the housing having a first section of a first cross-sectional shape and size near a second section of a second cross-sectional shape and size, the second cross-sectional size greater than the first cross-sectional size, said valve mechanism comprising:

a resiliently deformable piston head located within the housing such that the entire piston head is movable between the first and second sections, the piston head having a bore therethrough and a cross-sectional shape different from the first cross-sectional shape, the piston head having a maximum cross-sectional size greater than the first cross-sectional size such that when the piston head is within the first section the bore is closed; and

a resiliently deformable hollow biasing segment for biasing the piston head into the first section.

## 15

2. The valve mechanism of claim 1 wherein the maximum cross-sectional size is such that when the piston head is within the second section the bore is open.

3. The valve mechanism of claim 1 wherein the piston head is elliptical in cross-section and the first section of the housing is circular in cross-section.

4. The valve mechanism of claim 3 wherein the bore has a marquise-shaped cross-section having its major axis oriented perpendicularly to the major axis of the elliptical piston head.

5. A valve mechanism for forming a fluid-flow path within a medical connector having a hollow housing extending between an inlet port and an exit port, the housing having a first section of a first cross-sectional shape and size near a second section of a second cross-sectional shape and size, the second cross-sectional size greater than the first cross-sectional size, said valve mechanism comprising:

a resiliently deformable piston head located within the housing such that the entire piston head is movable between the first and second sections, the piston head having a marquise-shaped bore therethrough and a cross-sectional shape different from the first cross-sectional shape, the piston head having a maximum cross-sectional size, the bore oriented such that its major axis is perpendicular to the direction of the maximum cross-section, the maximum cross-sectional size being greater than the first cross-sectional size such that when the piston head is within the first section the bore is closed; and

a resiliently deformable hollow biasing segment for biasing the piston head into the first section.

6. The valve mechanism of claim 5 wherein the size of the maximum cross-section is such that when the piston head is within the second section the bore is open.

7. The valve mechanism of claim 5 wherein the piston head is elliptical in cross-section and the first section of the housing is circular in cross-section.

8. The valve mechanism of claim 7 wherein the maximum cross section comprises the major axis of the elliptical piston head.

9. A valve mechanism for forming a fluid-flow path within a medical connector having a hollow housing extending between an inlet port and an exit port, the housing having a first section of a first cross-sectional shape and size near a second section of a second cross-sectional shape and size, the second cross-sectional size greater than the first cross-sectional size, said valve mechanism comprising:

a resiliently deformable piston head located within the housing such that the entire piston head is movable between the first and second sections, the piston head having a bore therethrough and a cross-sectional shape different from the first cross-sectional shape, the piston head having a maximum cross-sectional size greater than the first cross-sectional size such that when the piston head is within the first section the bore is closed;

a resiliently deformable hollow biasing segment for biasing the piston head into the first section; and

a lock section at the junction of the piston head and the biasing segment, the lock section having a maximum cross-sectional size greater than the first cross-sectional size to limit proximal movement of the piston head to a position substantially flush with the inlet port.

## 16

10. A medical connector comprising:

a hollow housing including an adapter having an inlet port and a distal section having an exit port, the adapter having a first section of a first cross-sectional shape and size near a second section of a second cross-sectional shape and size, the second cross-sectional size greater than the first cross-sectional size; and

a valve mechanism for forming a fluid-flow path between the inlet port and the exit port, the valve mechanism comprising a resiliently deformable piston head entirely movable between the first and second sections, the piston head having a bore therethrough and a cross-sectional shape different from the first cross-sectional shape, the piston head having a maximum cross-sectional size greater than the first cross-sectional size such that when the piston head is within the first section the bore is closed, the valve mechanism further comprising a resiliently deformable hollow biasing segment for biasing the piston head into the first section.

11. The medical connector of claim 10 wherein the housing further includes a tubular section between the adapter and the distal section, the biasing segment is positioned within the tubular section, and the tubular section has an inner diameter greater than the maximum cross section of the biasing segment.

12. The medical connector of claim 11 further comprising a support tube disposed within the tubular section near the junction of the tubular section and the distal section, the support tube sized such that the biasing segment may be disposed about the support tube.

13. The medical connector of claim 11 further comprising a post disposed within the tubular section near the junction of the tubular section and the distal section, the post sized such that the biasing segment may be disposed about the support tube.

14. The medical connector of claim 13 wherein said post has a flattened cross-sectional shape.

15. The medical connector of claim 13 wherein the post is sized length-wise such that upon movement of the piston head into the second section the tip of the post extends into the piston head.

16. The medical connector of claim 10 wherein the size of the maximum cross-section is such that when the piston head is within the second section the bore is open.

17. The medical connector of claim 10 wherein the piston head is elliptical in cross-section and the first section of the housing is circular in cross-section.

18. The medical connector of claim 17 wherein the bore has a marquise-shaped cross-section having its major axis oriented perpendicularly to the major axis of the elliptical cross-section of the piston head.

19. The medical connector of claim 18 wherein the second section of the housing is circular in cross-section and the diameter of the second section is greater than the diameter of the first section.

20. The medical connector of claim 10 further comprising a lock section at the junction of the piston head and the biasing segment, the lock section having a maximum cross-sectional size greater than the first cross-sectional size to limit proximal movement of the piston head to a position substantially flush with the inlet port.

\* \* \* \* \*