



US008951286B2

(12) **United States Patent**
Sugimoto et al.

(10) **Patent No.:** **US 8,951,286 B2**
(45) **Date of Patent:** **Feb. 10, 2015**

(54) **TISSUE ANCHOR AND ANCHORING SYSTEM**

USPC 606/232, 139, 144-148, 157
See application file for complete search history.

(75) Inventors: **Hiroatsu Sugimoto**, Cambridge, MA (US); **Aaron M. Call**, Lowell, MA (US); **Karl R. Leinsing**, Hampton, NH (US)

(56) **References Cited**

U.S. PATENT DOCUMENTS

2,143,910 A	1/1939	Didusch
3,674,014 A	7/1972	Tillander
3,794,041 A	2/1974	Frei et al.
3,841,521 A	10/1974	Jarvik
3,959,960 A	6/1976	Santos
3,986,493 A	10/1976	Hendren, III
3,995,619 A	12/1976	Glatzer
4,042,979 A	8/1977	Angell
4,055,861 A	11/1977	Carpentier et al.
4,258,705 A	3/1981	Sorensen et al.

(Continued)

FOREIGN PATENT DOCUMENTS

EP	1016377 A2	7/2000
EP	2181670	5/2010

(Continued)

OTHER PUBLICATIONS

U.S. Patent and Trademark Office, Office Action in U.S. Appl. No. 10/949,412, Aug. 6, 2008.

(Continued)

Primary Examiner — Gregory Anderson
(74) *Attorney, Agent, or Firm* — Leason Ellis LLP

(57) **ABSTRACT**

A tissue anchor includes an anchor member formed from a generally flexible material. An activation member, which may be a tensioning member, causes proximal and distal end portions of the anchor member to move toward each other into a shortened configuration suitable for anchoring against the tissue. The tissue anchor can optionally be deployed and activated using a catheter device.

57 Claims, 15 Drawing Sheets

(73) Assignee: **Mitralign, Inc.**, Tewksbury, MA (US)

(*) Notice: Subject to any disclaimer, the term of this patent is extended or adjusted under 35 U.S.C. 154(b) by 0 days.

(21) Appl. No.: **12/273,670**

(22) Filed: **Nov. 19, 2008**

(65) **Prior Publication Data**

US 2009/0076547 A1 Mar. 19, 2009

Related U.S. Application Data

(62) Division of application No. 11/174,951, filed on Jul. 5, 2005.

(51) **Int. Cl.**
A61B 17/04 (2006.01)
A61B 17/00 (2006.01)

(52) **U.S. Cl.**
CPC **A61B 17/0401** (2013.01); **A61B 17/00234** (2013.01); **A61B 17/0487** (2013.01); **A61B 2017/00243** (2013.01); **A61B 2017/0417** (2013.01); **A61B 2017/0419** (2013.01); **A61B 2017/0458** (2013.01); **A61B 2017/0464** (2013.01); **A61B 2017/048** (2013.01); **A61B 2017/0496** (2013.01)

USPC **606/232**

(58) **Field of Classification Search**
CPC **A61B 17/0401**; **A61B 17/0487**; **A61B 2017/00243**; **A61B 2017/0496**

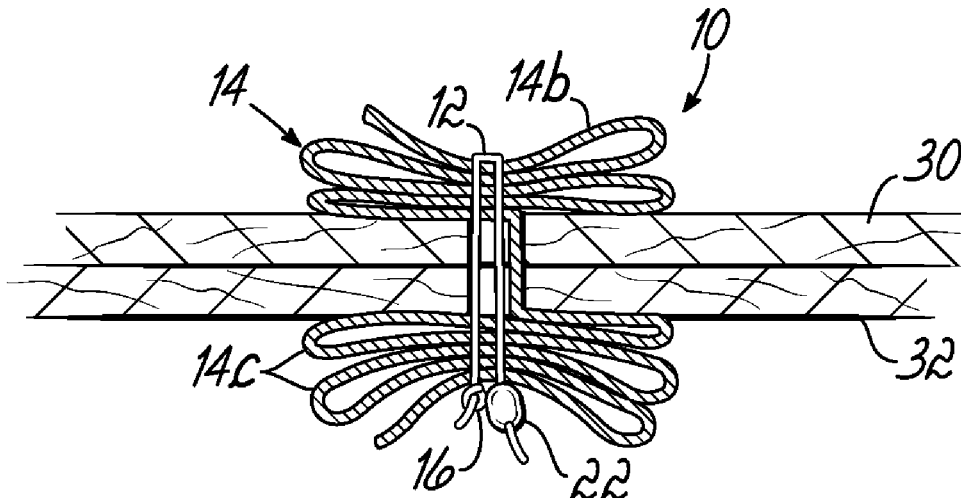

(56)

References Cited

U.S. PATENT DOCUMENTS

4,369,787	A	1/1983	Lasner et al.	6,113,611	A	9/2000	Allen et al.
4,489,446	A	12/1984	Reed	6,126,647	A	10/2000	Posey et al.
4,532,926	A	8/1985	O'Holla	RE36,974	E	11/2000	Bonutti
4,809,713	A	3/1989	Grayzel	6,159,234	A	12/2000	Bonutti et al.
4,917,698	A	4/1990	Carpentier et al.	6,162,168	A	12/2000	Schweich, Jr. et al.
4,945,912	A	8/1990	Langberg	6,165,119	A	12/2000	Schweich, Jr. et al.
5,016,353	A	5/1991	Iten	6,165,120	A	12/2000	Schweich, Jr. et al.
5,041,129	A	8/1991	Hayhurst et al.	6,165,183	A	12/2000	Kuehn et al.
5,041,130	A	8/1991	Cosgrove et al.	6,173,199	B1	1/2001	Gabriel
5,061,277	A	10/1991	Carpentier et al.	6,190,353	B1	2/2001	Makower et al.
5,104,407	A	4/1992	Lam et al.	6,197,017	B1	3/2001	Brock et al.
5,123,914	A	6/1992	Cope	6,206,895	B1	3/2001	Levinson
5,171,232	A	12/1992	Castillo et al.	6,210,432	B1	4/2001	Solem et al.
5,171,259	A	12/1992	Inoue	6,231,587	B1	5/2001	Makower
5,192,302	A	3/1993	Kensey et al.	6,267,781	B1	7/2001	Tu
5,201,880	A	4/1993	Wright et al.	6,269,819	B1	8/2001	Oz et al.
5,203,777	A	4/1993	Lee	6,285,903	B1	9/2001	Rosenthal et al.
5,304,190	A	4/1994	Reckelhoff et al.	6,287,317	B1	9/2001	Makower et al.
5,306,234	A	4/1994	Johnson	6,298,257	B1	10/2001	Hall et al.
5,306,296	A	4/1994	Wright et al.	6,306,133	B1	10/2001	Tu et al.
5,337,736	A	8/1994	Reddy	6,312,447	B1	11/2001	Grimes
5,360,444	A	11/1994	Kusuhara	6,319,263	B1	11/2001	Levinson
5,364,365	A	11/1994	Wortrich	6,332,089	B1	12/2001	Acker et al.
5,364,393	A	11/1994	Auth et al.	6,332,893	B1	12/2001	Mortier et al.
5,429,131	A	7/1995	Scheinman et al.	6,352,543	B1	3/2002	Cole
5,450,860	A	9/1995	O'Connor	6,385,472	B1	5/2002	Hall et al.
5,452,513	A	9/1995	Zinnbauer et al.	6,401,720	B1	6/2002	Stevens et al.
5,464,023	A	11/1995	Viera	6,402,680	B2	6/2002	Mortier et al.
5,545,178	A *	8/1996	Kensey et al. 606/213	6,402,781	B1	6/2002	Langberg et al.
5,565,122	A	10/1996	Zinnbauer et al.	6,406,420	B1	6/2002	McCarthy et al.
5,571,215	A	11/1996	Sterman et al.	6,447,522	B2	9/2002	Gambale et al.
5,593,424	A	1/1997	Northrup	6,461,366	B1	10/2002	Seguin
5,607,471	A	3/1997	Seguin et al.	6,500,184	B1	12/2002	Chan et al.
5,623,943	A	4/1997	Hackett et al.	6,524,303	B1	2/2003	Garibaldi
5,626,590	A	5/1997	Wilk	6,530,952	B2	3/2003	Vesely
5,640,955	A	6/1997	Ockuly et al.	6,537,198	B1	3/2003	Vidlund et al.
5,669,919	A	9/1997	Sanders et al.	6,537,314	B2	3/2003	Langberg et al.
5,674,279	A	10/1997	Wright et al.	6,542,766	B2	4/2003	Hall et al.
5,682,906	A	11/1997	Sterman et al.	6,544,230	B1	4/2003	Flaherty et al.
5,690,656	A	11/1997	Cope et al.	6,554,852	B1	4/2003	Oberlander
5,706,827	A	1/1998	Ehr et al.	6,562,019	B1	5/2003	Sell
5,716,367	A	2/1998	Koike et al.	6,565,562	B1	5/2003	Shah et al.
5,716,397	A	2/1998	Myers	6,589,208	B2	7/2003	Ewers et al.
5,716,399	A	2/1998	Love	6,594,517	B1	7/2003	Nevo
5,776,080	A	7/1998	Thome et al.	6,596,014	B2	7/2003	Levinson et al.
5,776,189	A	7/1998	Khalid	6,619,291	B2	9/2003	Hlavka et al.
5,797,939	A	8/1998	Yoon	6,626,899	B2	9/2003	Houser et al.
5,813,996	A	9/1998	St. Germain et al.	6,626,919	B1	9/2003	Swanstrom
5,824,066	A	10/1998	Gross	6,626,930	B1	9/2003	Allen et al.
5,827,300	A	10/1998	Fleega	6,629,534	B1	10/2003	St. Goar et al.
5,829,447	A	11/1998	Stevens et al.	6,629,921	B1	10/2003	Schweich, Jr. et al.
5,830,224	A	11/1998	Cohn et al.	6,655,386	B1	12/2003	Makower et al.
5,851,185	A	12/1998	Berns	6,656,221	B2	12/2003	Taylor et al.
5,860,920	A	1/1999	McGee et al.	6,669,687	B1	12/2003	Saadat
5,868,733	A	2/1999	Ockuly et al.	6,669,707	B1	12/2003	Swanstrom et al.
5,879,366	A *	3/1999	Shaw et al. 606/213	6,676,702	B2	1/2004	Mathis
5,888,240	A	3/1999	Carpentier et al.	6,689,164	B1	2/2004	Seguin
5,906,579	A	5/1999	Vander Salm et al.	6,699,263	B2	3/2004	Cope
5,911,720	A	6/1999	Bourne et al.	6,702,825	B2	3/2004	Frazier et al.
5,928,224	A	7/1999	Laufer	6,702,826	B2	3/2004	Liddicoat et al.
5,931,818	A	8/1999	Werp et al.	6,718,985	B2	4/2004	Hlavka et al.
5,944,738	A	8/1999	Amplatz et al.	6,723,038	B1	4/2004	Schroeder et al.
5,967,984	A	10/1999	Chu et al.	6,730,112	B2	5/2004	Levinson
5,980,515	A	11/1999	Tu	6,733,509	B2	5/2004	Nobles et al.
5,984,939	A	11/1999	Yoon	6,736,808	B1	5/2004	Motamedi et al.
6,015,414	A	1/2000	Werp et al.	6,746,472	B2	6/2004	Frazier et al.
6,027,514	A	2/2000	Stine et al.	6,764,500	B1	7/2004	Muijs Van De Moer et al.
6,042,581	A	3/2000	Ryan et al.	6,769,434	B2	8/2004	Liddicoat et al.
6,050,472	A	4/2000	Shibata	6,793,618	B2	9/2004	Schweich, Jr. et al.
6,050,936	A	4/2000	Schweich, Jr. et al.	6,866,673	B2	3/2005	Oren et al.
6,068,637	A	5/2000	Popov et al.	6,913,608	B2	7/2005	Liddicoat et al.
6,068,648	A	5/2000	Cole et al.	6,921,407	B2	7/2005	Nguyen et al.
6,071,292	A	6/2000	Makower et al.	6,923,823	B1	8/2005	Bartlett et al.
6,099,460	A	8/2000	Denker	6,942,694	B2	9/2005	Liddicoat et al.
6,102,945	A	8/2000	Campbell	6,945,978	B1	9/2005	Hyde
				6,964,674	B1	11/2005	Matsuura et al.
				6,964,683	B2	11/2005	Kowalsky et al.
				6,976,995	B2	12/2005	Mathis et al.
				7,004,958	B2	2/2006	Adams et al.

(56)

References Cited

U.S. PATENT DOCUMENTS

7,037,334 B1 5/2006 Hlavka et al.
 7,101,395 B2 9/2006 Tremulis et al.
 7,115,110 B2 10/2006 Frazier et al.
 7,166,127 B2 1/2007 Spence et al.
 7,211,094 B2 5/2007 Gannoe et al.
 7,247,134 B2 7/2007 Vidlund et al.
 7,731,732 B2 6/2010 Ken
 7,749,250 B2 7/2010 Stone et al.
 7,771,455 B2 8/2010 Ken
 7,883,538 B2 2/2011 To et al.
 7,931,580 B2 4/2011 Gertner et al.
 8,172,871 B2 5/2012 Ken
 2001/0005787 A1 6/2001 Oz et al.
 2001/0039436 A1 11/2001 Frazier et al.
 2001/0049492 A1 12/2001 Frazier et al.
 2002/0013571 A1 1/2002 Goldfarb et al.
 2002/0016628 A1 2/2002 Langberg et al.
 2002/0019649 A1 2/2002 Sikora et al.
 2002/0026198 A1 2/2002 Ockuly et al.
 2002/0026216 A1 2/2002 Grimes
 2002/0029080 A1 3/2002 Mortier et al.
 2002/0042621 A1 4/2002 Liddicoat et al.
 2002/0072758 A1 6/2002 Reo et al.
 2002/0087169 A1 7/2002 Brock et al.
 2002/0087173 A1 7/2002 Alferness et al.
 2002/0087178 A1 7/2002 Nobles et al.
 2002/0095167 A1 7/2002 Liddicoat et al.
 2002/0100485 A1 8/2002 Stevens et al.
 2002/0103532 A1 8/2002 Langberg et al.
 2002/0107531 A1 8/2002 Schreck et al.
 2002/0128708 A1 9/2002 Northrup, III et al.
 2002/0156526 A1 10/2002 Hlavka et al.
 2002/0165535 A1 11/2002 Lesh et al.
 2002/0169359 A1 11/2002 McCarthy et al.
 2002/0169502 A1 11/2002 Mathis
 2002/0169504 A1 11/2002 Alferness et al.
 2002/0173841 A1 11/2002 Ortiz et al.
 2002/0183766 A1 12/2002 Seguin
 2002/0183836 A1 12/2002 Liddicoat et al.
 2002/0183837 A1 12/2002 Streeter et al.
 2002/0183838 A1 12/2002 Liddicoat et al.
 2002/0183841 A1 12/2002 Cohn et al.
 2002/0188170 A1 12/2002 Santamore et al.
 2003/0018358 A1 1/2003 Saadat
 2003/0069593 A1 4/2003 Tremulis et al.
 2003/0069636 A1 4/2003 Solem et al.
 2003/0078465 A1 4/2003 Pai et al.
 2003/0078654 A1 4/2003 Taylor et al.
 2003/0078671 A1 4/2003 Lesniak et al.
 2003/0083538 A1 5/2003 Adams et al.
 2003/0105474 A1 6/2003 Bonutti
 2003/0105520 A1 6/2003 Alferness et al.
 2003/0120340 A1 6/2003 Liska et al.
 2003/0130730 A1 7/2003 Cohn et al.
 2003/0144697 A1 7/2003 Mathis et al.
 2003/0160721 A1 8/2003 Gilboa et al.
 2003/0171776 A1 9/2003 Adams et al.
 2003/0171806 A1 9/2003 Mathis et al.
 2003/0199974 A1 10/2003 Lee et al.
 2003/0204205 A1 10/2003 Sauer et al.
 2003/0208195 A1 11/2003 Thompson et al.
 2003/0212453 A1 11/2003 Mathis et al.
 2003/0220685 A1 11/2003 Hlvka et al.
 2003/0233142 A1 12/2003 Morales et al.
 2004/0003819 A1 1/2004 St. Goar et al.
 2004/0019378 A1 1/2004 Hlavka et al.
 2004/0024414 A1 2/2004 Downing
 2004/0030382 A1 2/2004 St. Goar et al.
 2004/0039442 A1 2/2004 St. Goar et al.
 2004/0044364 A1 3/2004 DeVries et al.
 2004/0049211 A1 3/2004 Tremulis et al.
 2004/0092962 A1 5/2004 Thornton et al.
 2004/0093023 A1 5/2004 Allen et al.
 2004/0097865 A1 5/2004 Anderson et al.
 2004/0122456 A1 6/2004 Saadat et al.

2004/0127983 A1 7/2004 Mortier et al.
 2004/0133063 A1 7/2004 McCarthy et al.
 2004/0147958 A1 7/2004 Lam et al.
 2004/0152947 A1 8/2004 Schroeder et al.
 2004/0162568 A1 8/2004 Saadat et al.
 2004/0167539 A1 8/2004 Kuehn et al.
 2004/0167620 A1 8/2004 Ortiz et al.
 2004/0172046 A1 9/2004 Hlavka et al.
 2004/0186486 A1 9/2004 Roue et al.
 2004/0186566 A1 9/2004 Hindrichs et al.
 2004/0193191 A1 9/2004 Starksen et al.
 2004/0220473 A1 11/2004 Lualdi
 2004/0236419 A1 11/2004 Milo
 2004/0243153 A1 12/2004 Liddicoat et al.
 2004/0243227 A1 12/2004 Starksen et al.
 2004/0260317 A1 12/2004 Bloom et al.
 2005/0033446 A1 2/2005 Deem et al.
 2005/0049634 A1 3/2005 Chopra
 2005/0049681 A1 3/2005 Greenhalgh et al.
 2005/0055087 A1 3/2005 Starksen
 2005/0055089 A1 3/2005 Macoviak et al.
 2005/0065550 A1 3/2005 Starksen et al.
 2005/0065601 A1 3/2005 Lee et al.
 2005/0075723 A1 4/2005 Schroeder et al.
 2005/0107810 A1 5/2005 Morales et al.
 2005/0107812 A1 5/2005 Starksen et al.
 2005/0107871 A1 5/2005 Realyvasquez et al.
 2005/0119523 A1 6/2005 Starksen et al.
 2005/0119734 A1 6/2005 Spence et al.
 2005/0119735 A1 6/2005 Spence et al.
 2005/0125011 A1 6/2005 Spence et al.
 2005/0131438 A1 6/2005 Cohn
 2005/0143811 A1 6/2005 Realyvasquez
 2005/0148815 A1 7/2005 Mortier et al.
 2005/0149014 A1 7/2005 Hauck et al.
 2005/0159810 A1 7/2005 Filsoufi
 2005/0177228 A1 8/2005 Solem et al.
 2005/0184122 A1 8/2005 Hlavka et al.
 2005/0197693 A1 9/2005 Pai et al.
 2005/0216039 A1 9/2005 Lederman
 2005/0234481 A1 10/2005 Waller
 2005/0251157 A1 11/2005 Saadat et al.
 2005/0251159 A1 11/2005 Ewers et al.
 2005/0251202 A1 11/2005 Ewers et al.
 2005/0251205 A1 11/2005 Ewers et al.
 2005/0251206 A1 11/2005 Maahs et al.
 2005/0251207 A1 11/2005 Flores et al.
 2005/0251208 A1* 11/2005 Elmer et al. 606/232
 2005/0251209 A1 11/2005 Saadat et al.
 2005/0251210 A1 11/2005 Westra et al.
 2005/0267533 A1 12/2005 Gertner
 2005/0267571 A1 12/2005 Spence et al.
 2005/0283192 A1 12/2005 Torrie et al.
 2005/0288694 A1 12/2005 Solomon
 2006/0004410 A1 1/2006 Nobis et al.
 2006/0009784 A1 1/2006 Behl et al.
 2006/0069429 A1 3/2006 Spence et al.
 2006/0142756 A1 6/2006 Davies et al.
 2006/0161040 A1 7/2006 McCarthy et al.
 2006/0178682 A1 8/2006 Boehlke
 2006/0212045 A1 9/2006 Schilling et al.
 2007/0010857 A1 1/2007 Sugimoto et al.
 2007/0055303 A1 3/2007 Vidlund et al.
 2007/0080188 A1 4/2007 Spence et al.
 2007/0106310 A1 5/2007 Goldin et al.
 2007/0112424 A1 5/2007 Spence et al.
 2008/0228165 A1 9/2008 Spence et al.
 2008/0228198 A1 9/2008 Traynor et al.
 2008/0228265 A1 9/2008 Spence et al.
 2008/0228266 A1 9/2008 McNamara et al.
 2008/0228267 A1 9/2008 Spence et al.
 2008/0275503 A1 11/2008 Spence et al.
 2009/0018655 A1 1/2009 Brunelle et al.

FOREIGN PATENT DOCUMENTS

WO 9604852 A1 2/1996
 WO 9900059 A1 1/1999
 WO 0003759 A2 1/2000

(56)

References Cited

FOREIGN PATENT DOCUMENTS

WO	0044311	A2	8/2000
WO	0060995	A2	10/2000
WO	0067640	A2	11/2000
WO	0200099	A2	1/2002
WO	02051329	A1	7/2002
WO	02096275	A2	12/2002
WO	03001893	A2	1/2003
WO	03007796	A2	1/2003
WO	03053289	A1	7/2003
WO	WO 2004/037317		5/2004
WO	2004045378	A2	6/2004
WO	2004112658	A1	12/2004
WO	2005011463	A2	2/2005
WO	2005013832	A1	2/2005
WO	2005025644	A2	3/2005
WO	WO 2005058239		6/2005
WO	2006064490	A1	6/2006
WO	WO 2006105008		10/2006
WO	2007005394	A1	1/2007
WO	WO 2008091391		7/2008

OTHER PUBLICATIONS

U.S. Patent and Trademark Office, Office Action in U.S. Appl. No. 10/689,872, Aug. 8, 2008.

U.S. Patent and Trademark Office, Office Action in U.S. Appl. No. 10/622,207, Apr. 11, 2008.

U.S. Patent and Trademark Office, Office Action in U.S. Appl. No. 10/948,923, Mar. 18, 2008.

U.S. Patent and Trademark Office, International Search Report and Written Opinion in PCT Application No. PCT/US2008/056620, Oct. 15, 2008.

U.S. Patent and Trademark Office, International Search Report and Written Opinion in PCT Application No. PCT/US2008/080735, Dec. 17, 2008.

Cardiac Surgery Renaissance, Anatomical Landscape; Composite Profile of CABG and Valve Procedures, Apr. 25, 1996, Cardiology Roundtable Interviews.

F. Maisano et al., The Double-Orifice Technique as a Standardized Approach to Treat Mitral Regurgitation Due to Severe Myxomatous Disease: Surgical Technique, European Journal of Cardio-thoracic Surgery, 1998.

Douglas P. Zipes, Md et al., Ablation of Free Wall Accessory Pathways, Catheter Ablation of Arrhythmias, Chapter 8, 7 pgs., 1994.

Gsolt L. Nagy et al., Mitral Annuloplasty with a Suture Technique, European Journal of Cardio-thoracic Surgery 18, Aug. 15, 2000, 1 pg.

David L.S. Morales et al., Development of an Off Bypass Mitral Valve Repair, Department of Surgery, Columbia University, College of Physicians and Surgeons, New York, NY.

http://www.hsforum.com/vol2/issue2/1999-4963_tables.html.

<http://www.hsforum.com/vol2/issue2/1999-4963figures.html>.

http://medtronic.com/cardiac/heartvalves/duran_band/.

European Patent Office, Supplementary Search Report in EP Application No. 02764186.9, Jan. 26, 2007.

European Patent Office, Supplementary Search Report in EP Application No. 02733960.5, Jan. 25, 2007.

European Patent Office, International Search Report and Written Opinion in PCT Application No. PCT/US2006/024897, Dec. 6, 2006.

U.S. Patent and Trademark Office, Office Action in U.S. Appl. No. 10/948,922, Sep. 11, 2007.

U.S. Patent and Trademark Office, Office Action in U.S. Appl. No. 11/111,044, Jul. 16, 2007.

U.S. Patent and Trademark Office, Office Action in U.S. Appl. No. 10/622,207, May 21, 2007.

U.S. Patent and Trademark Office, Office Action in U.S. Appl. No. 10/622,207, Jul. 14, 2006.

U.S. Patent and Trademark Office, Office Action in U.S. Appl. No. 10/622,207, Aug. 23, 2005.

U.S. Patent and Trademark Office, Office Action in U.S. Appl. No. 10/622,207, Dec. 28, 2004.

European Patent Office, European Examination Report in Application Serial No. 02764186.9, Feb. 11, 2008.

U.S. Patent and Trademark Office, Office Action in U.S. Appl. No. 11/111,044, Feb. 26, 2008.

U.S. Patent and Trademark Office, Office Action in U.S. Appl. No. 10/949,133, Dec. 10, 2008.

* cited by examiner

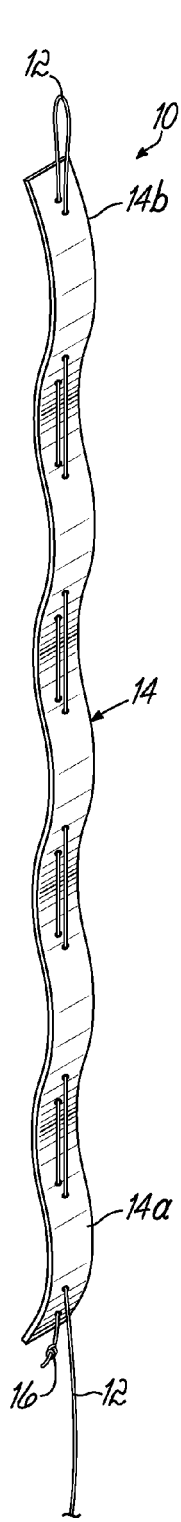

FIG. 1

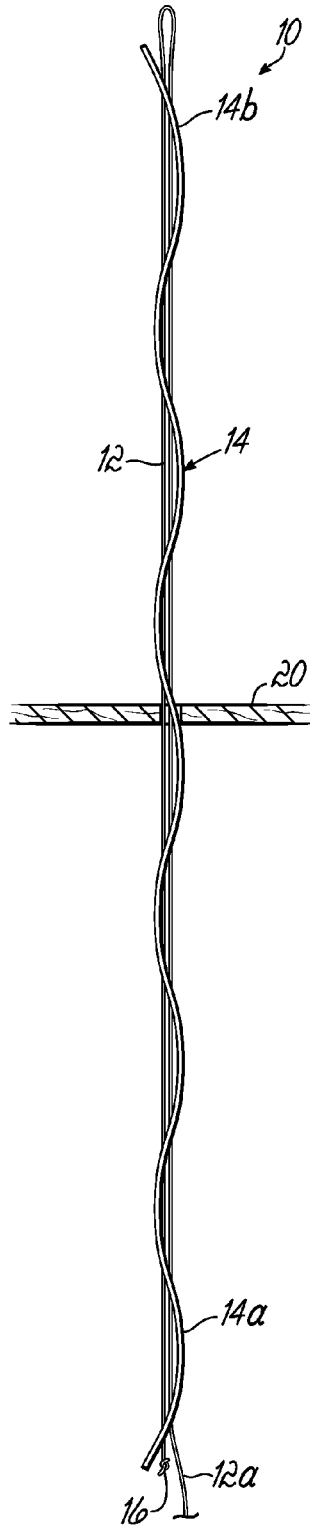

FIG. 2A

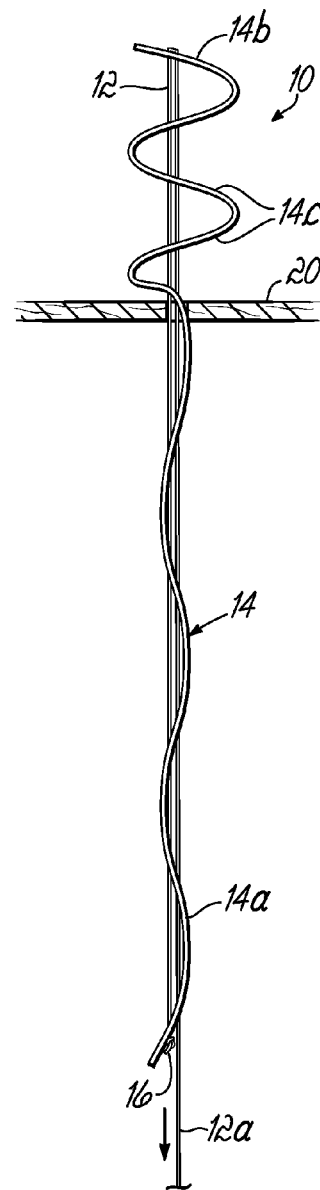

FIG. 2B

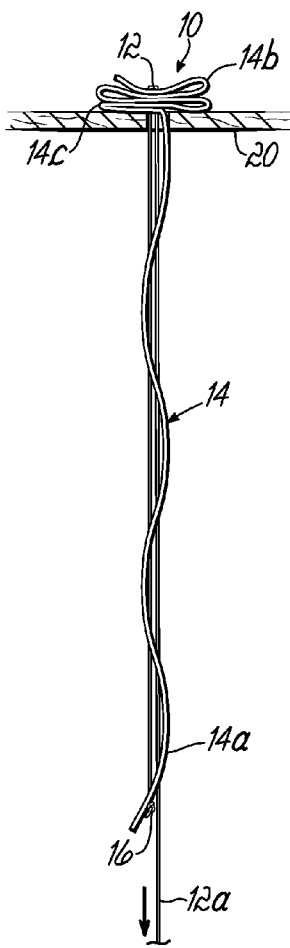

FIG. 2C

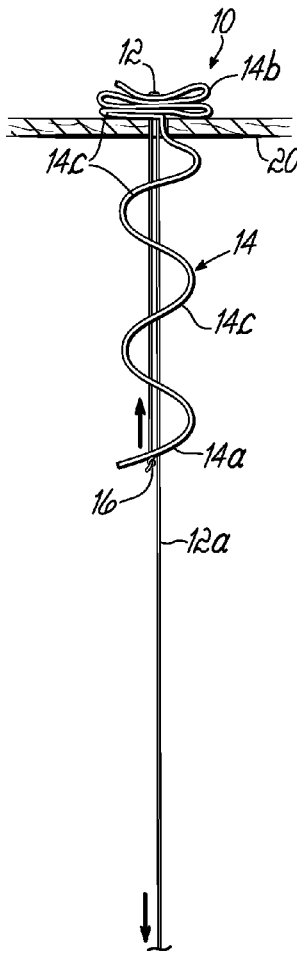

FIG. 2D

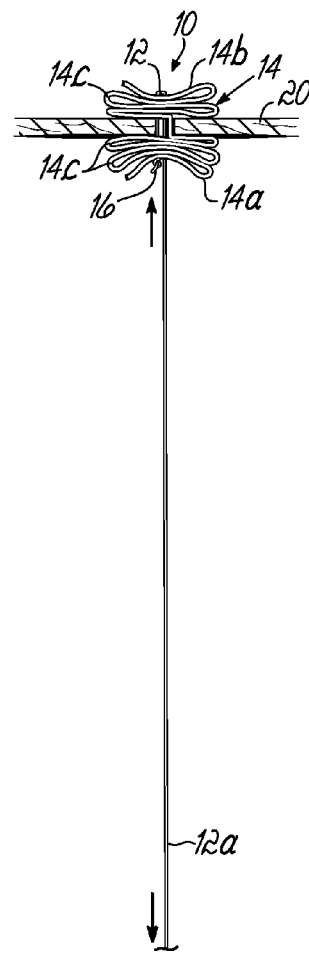

FIG. 2E

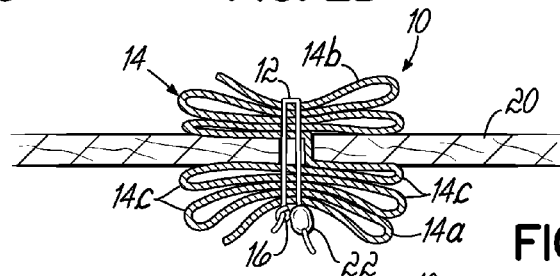

FIG. 2F

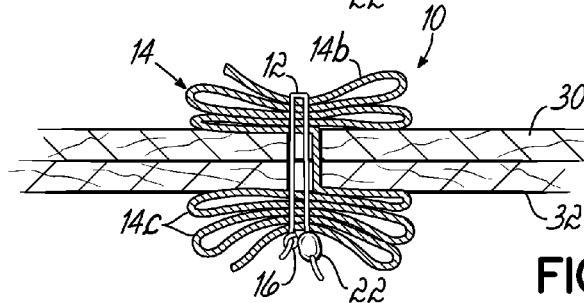

FIG. 3

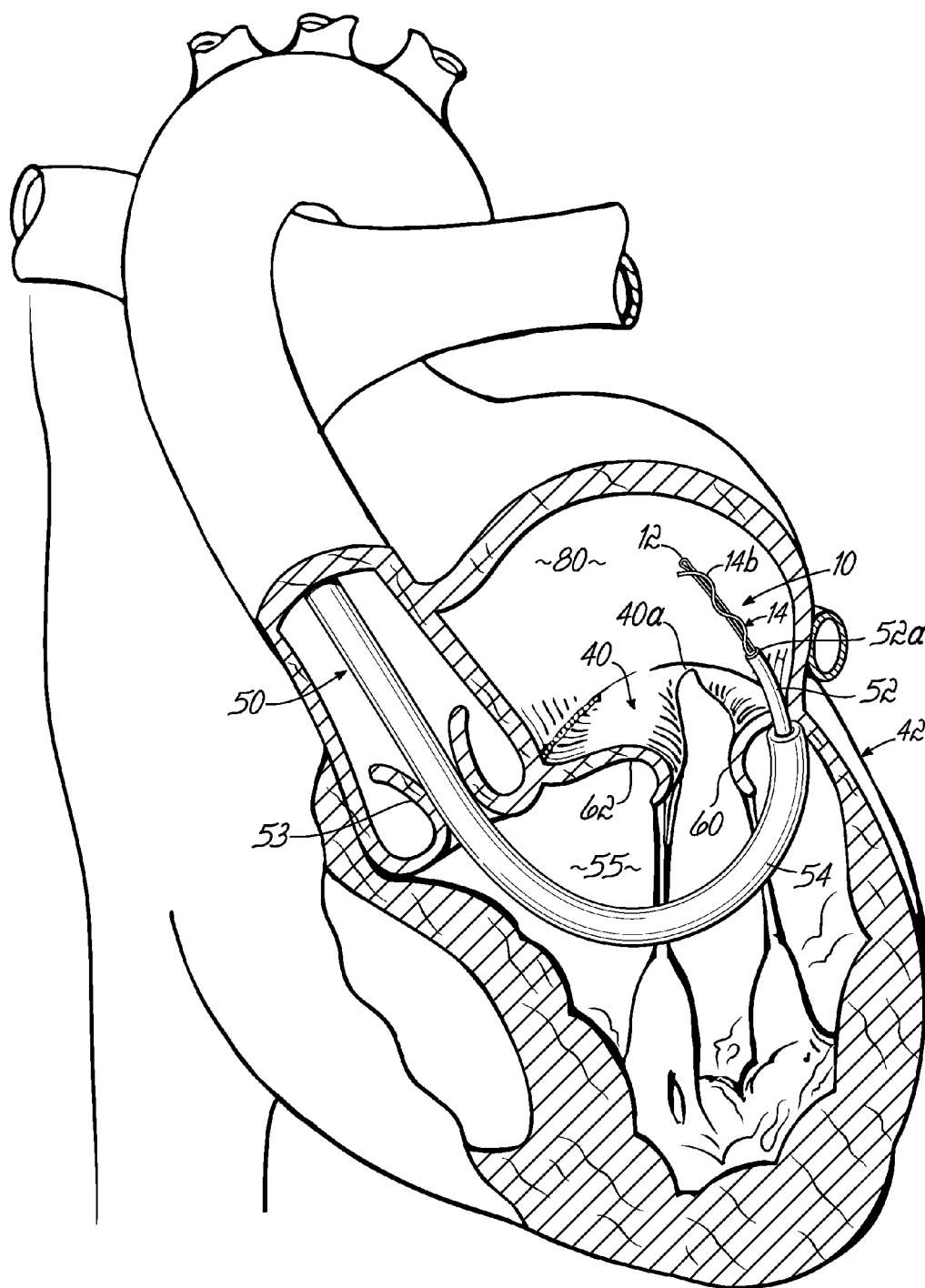
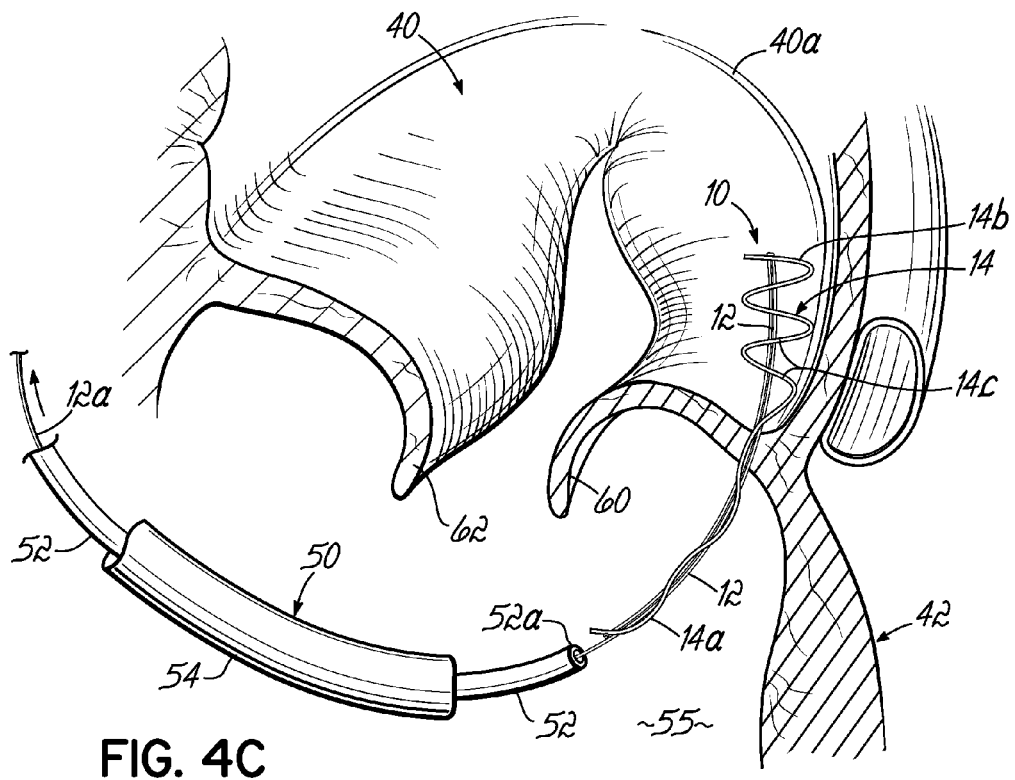
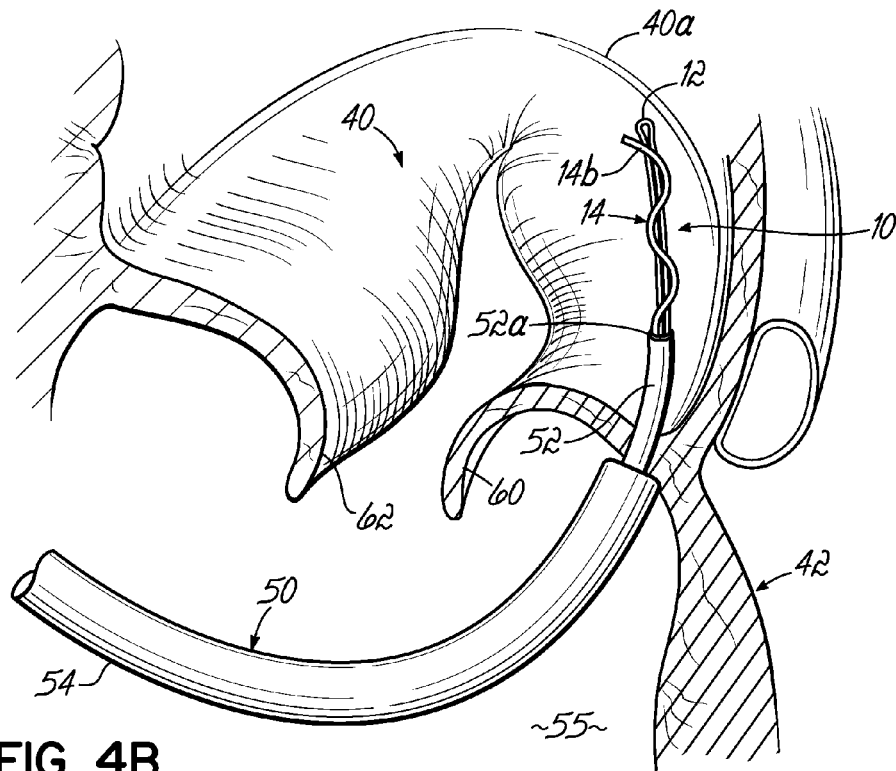

FIG. 4A



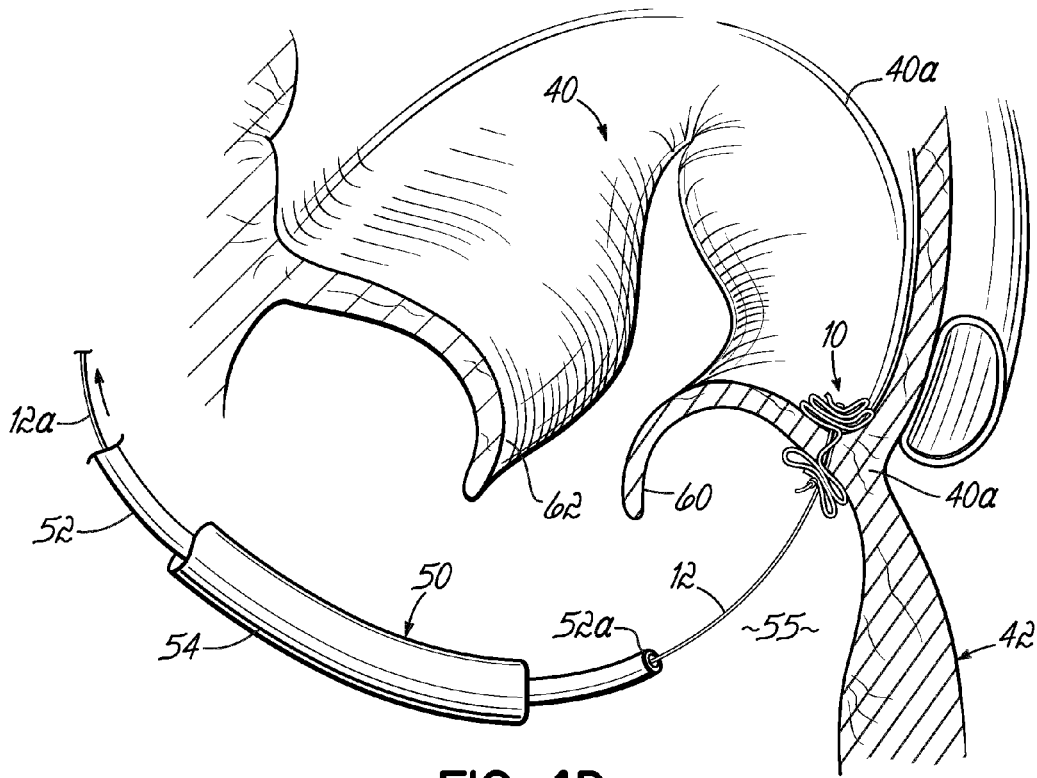

FIG. 4D

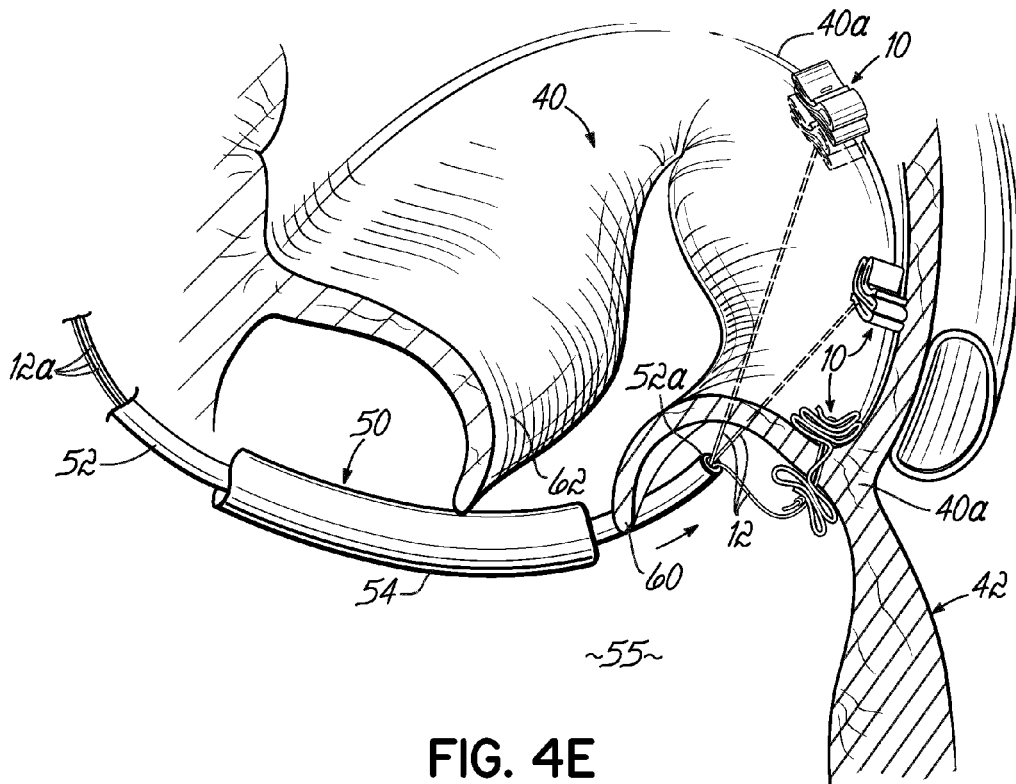

FIG. 4E

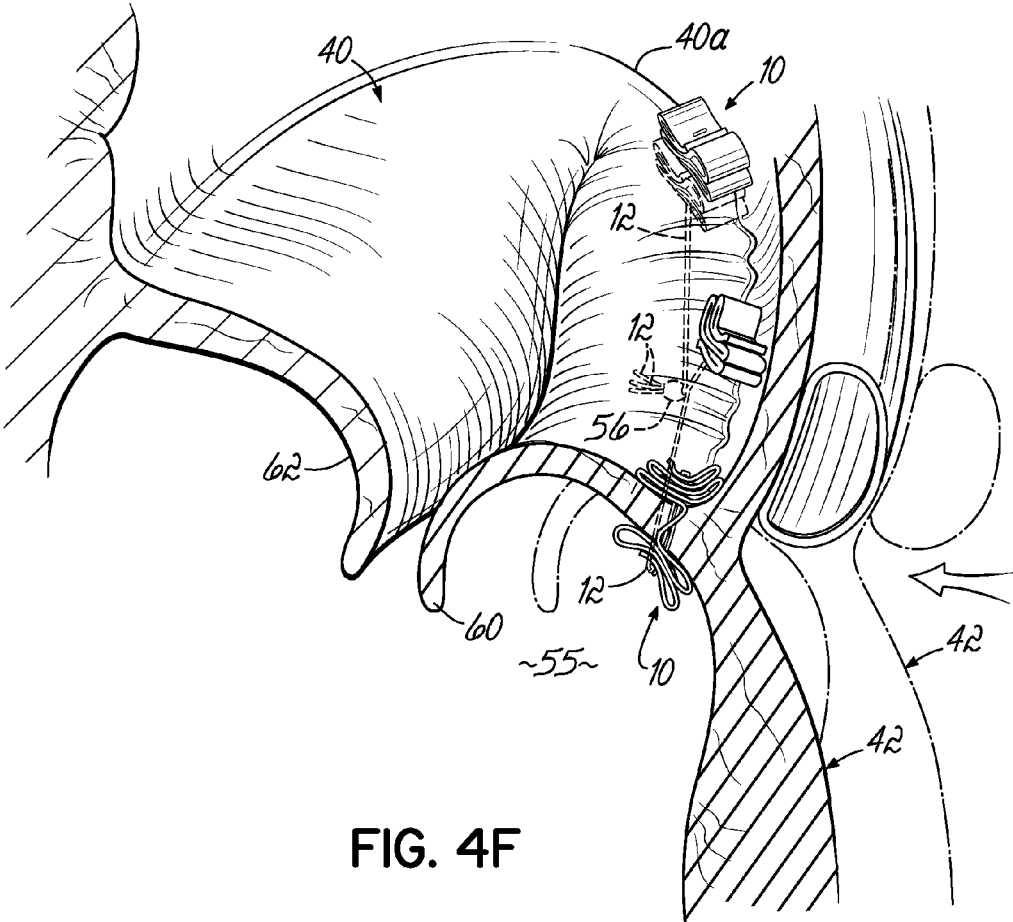

FIG. 4F

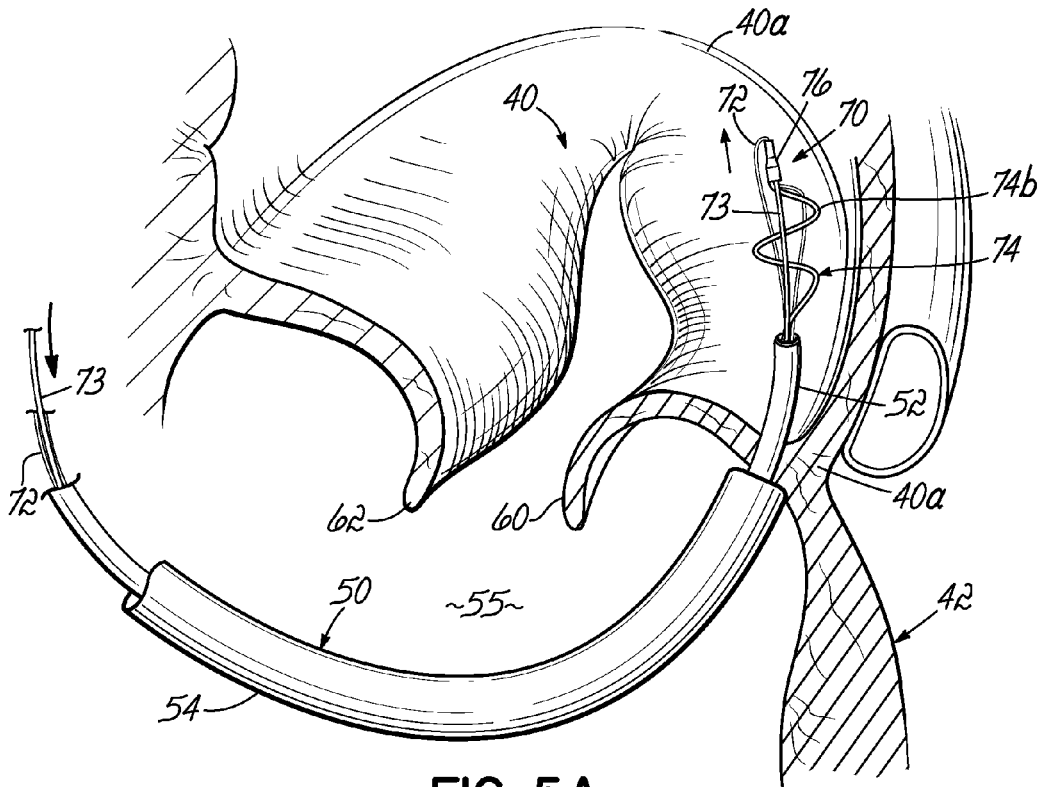

FIG. 5A

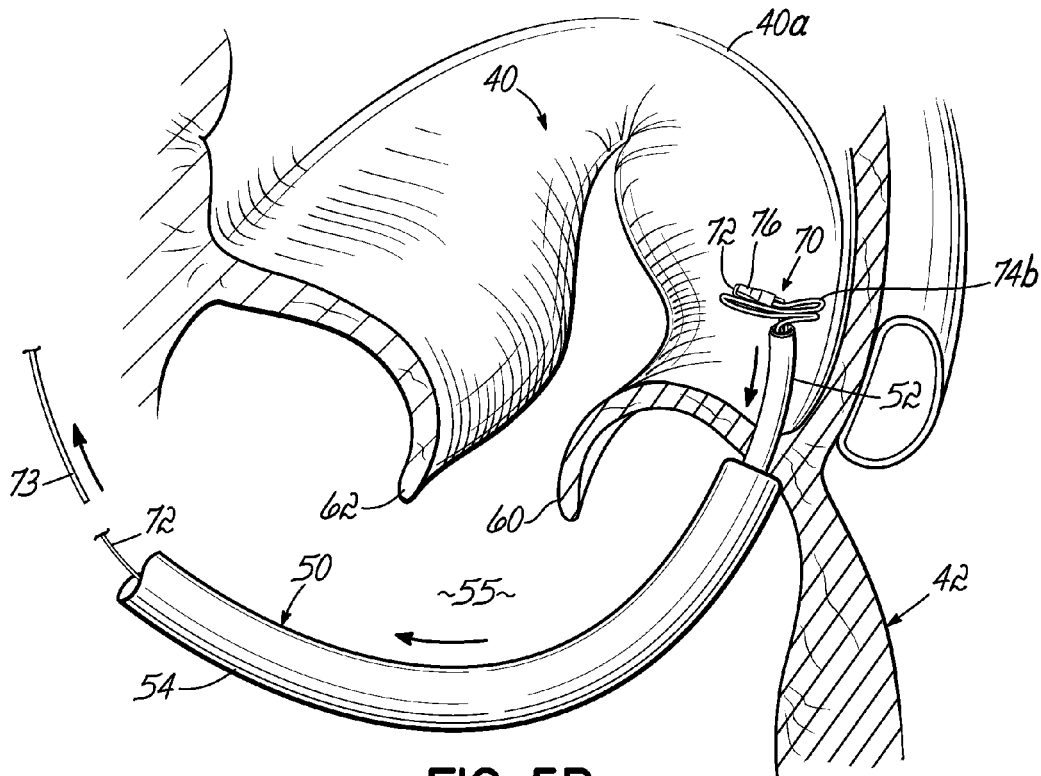
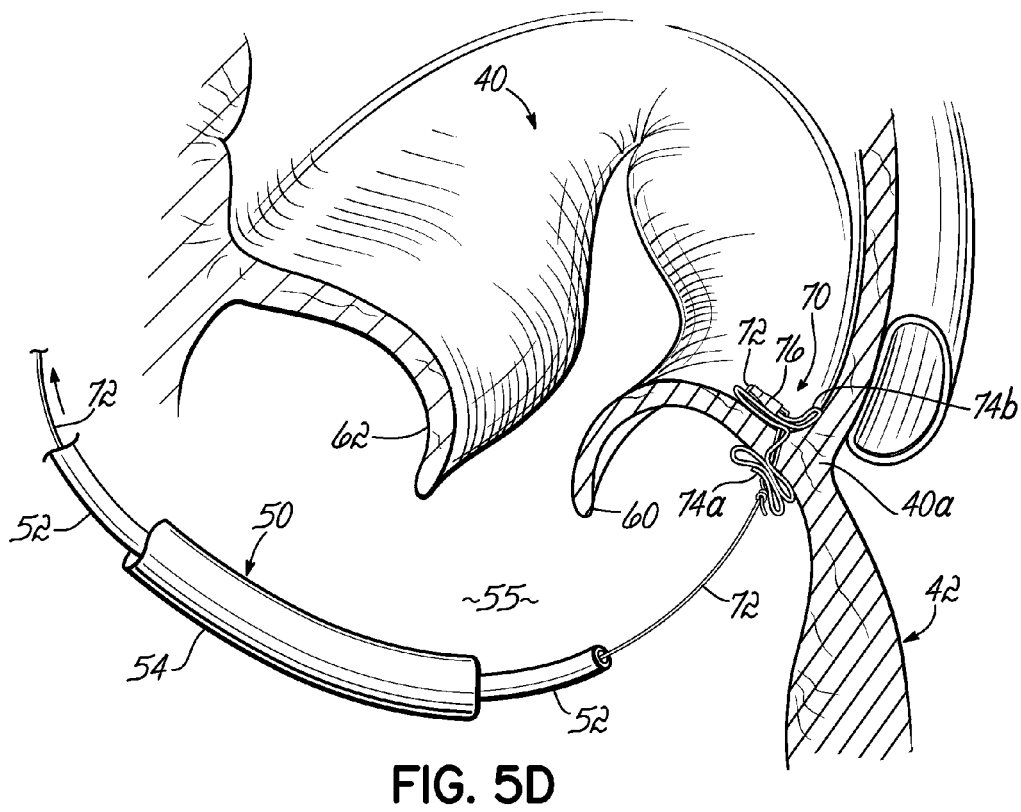
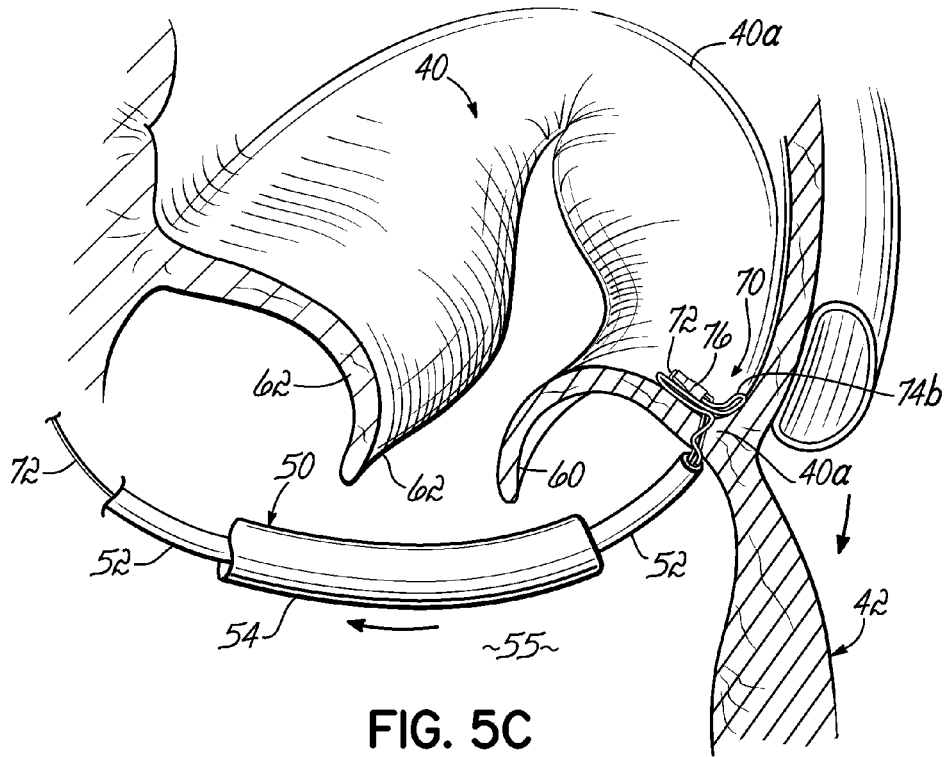

FIG. 5B



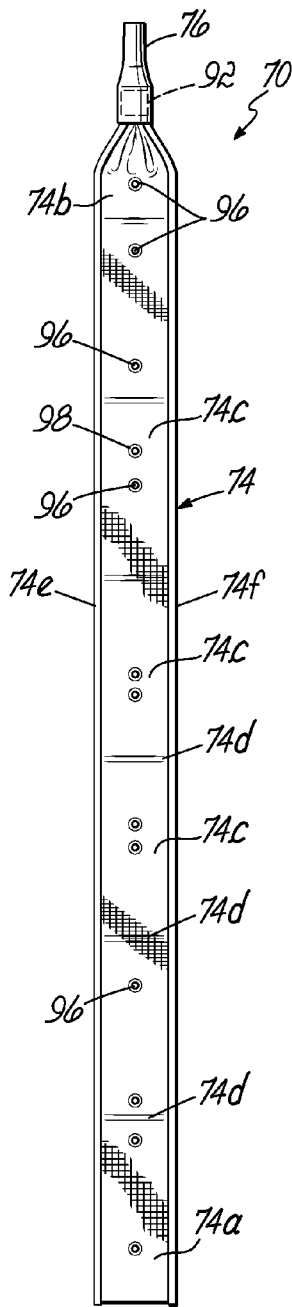
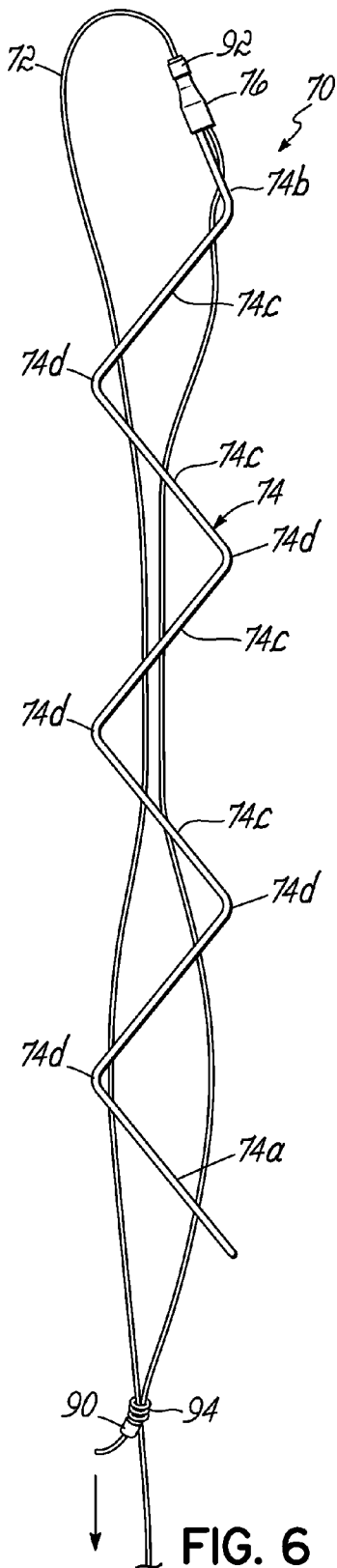

FIG. 7

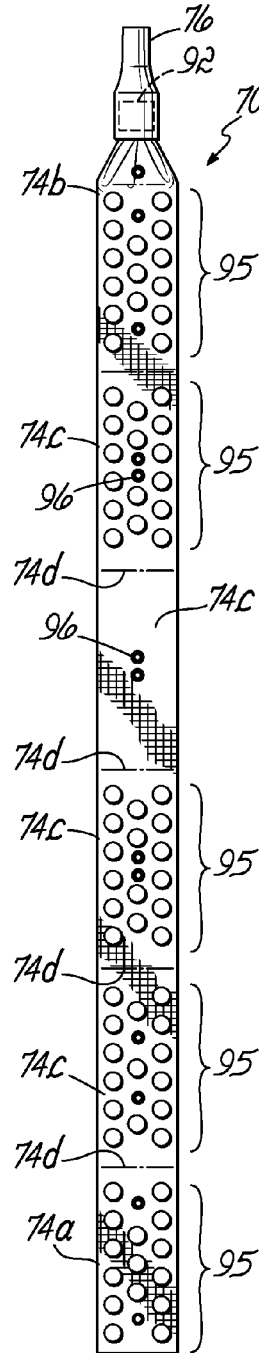

FIG. 7A

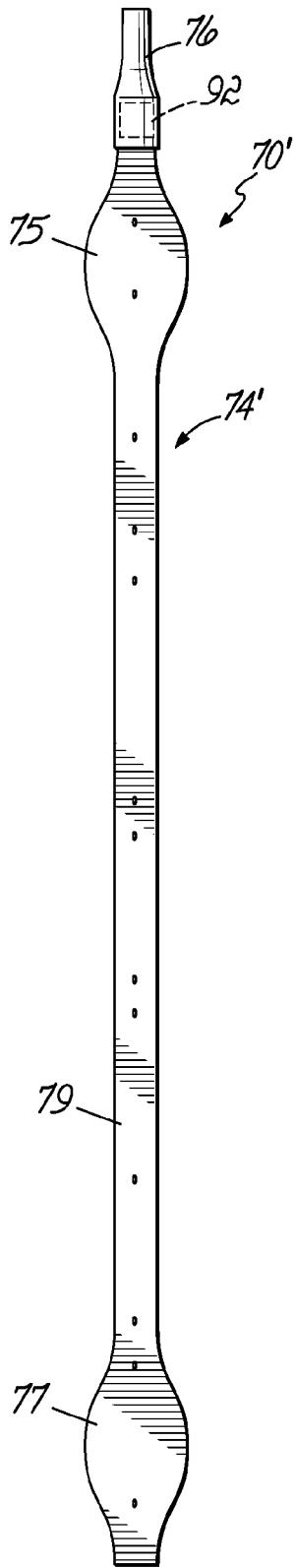

FIG. 7B

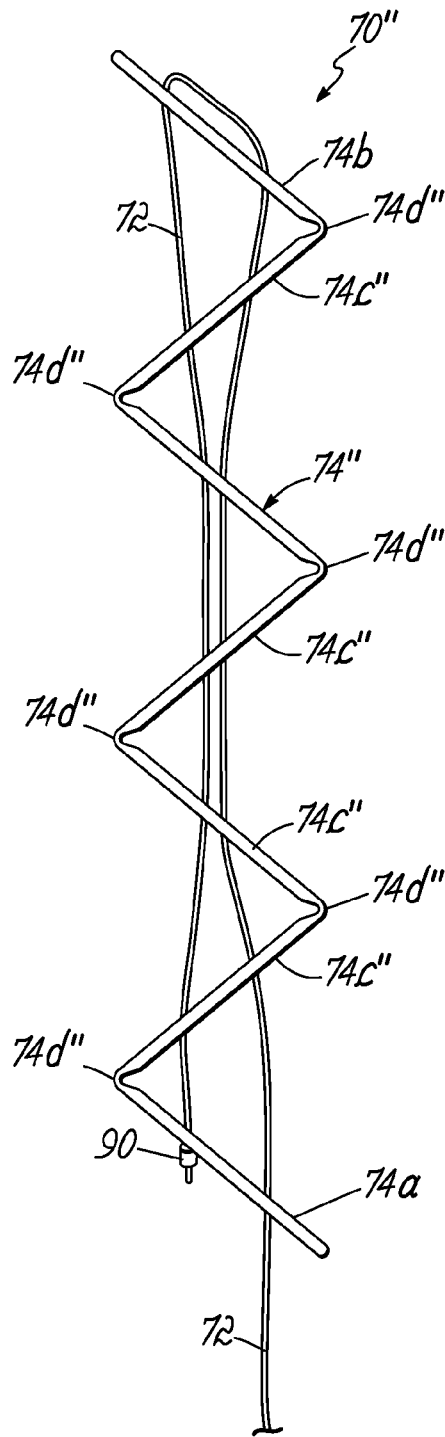

FIG. 7C

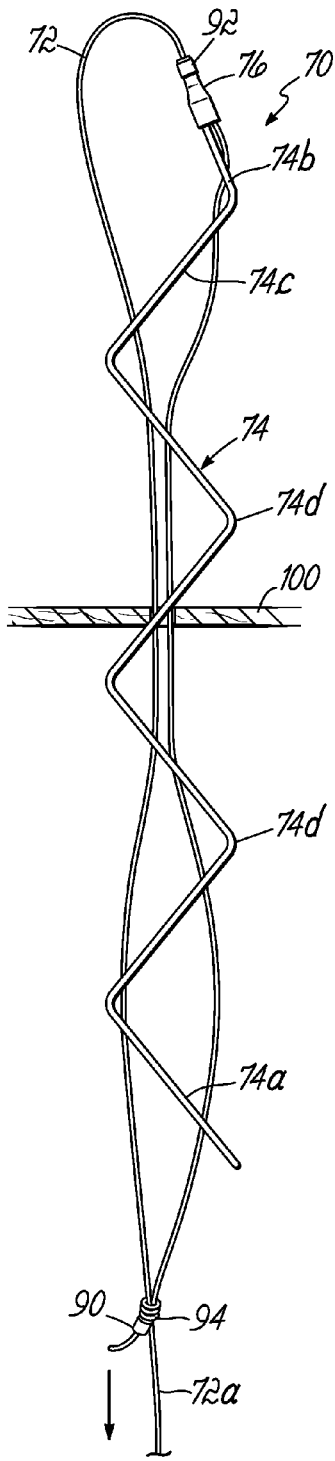

FIG. 8A

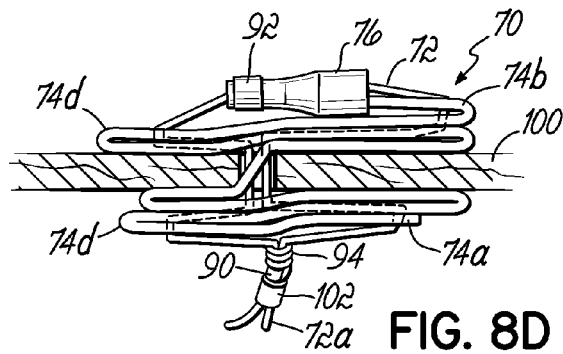

FIG. 8D

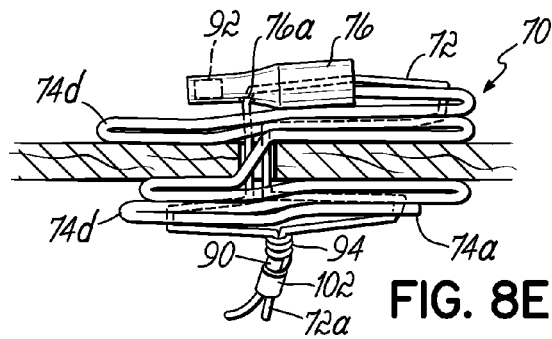

FIG. 8E

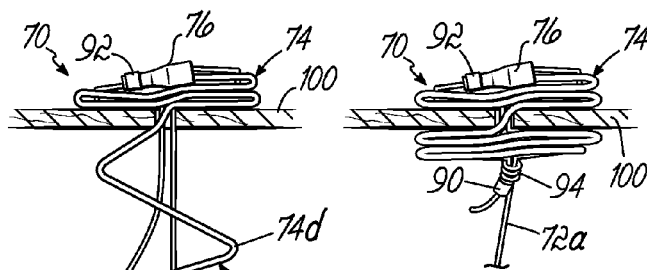

FIG. 8C

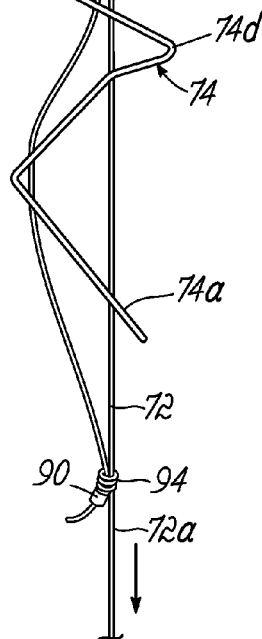

FIG. 8B

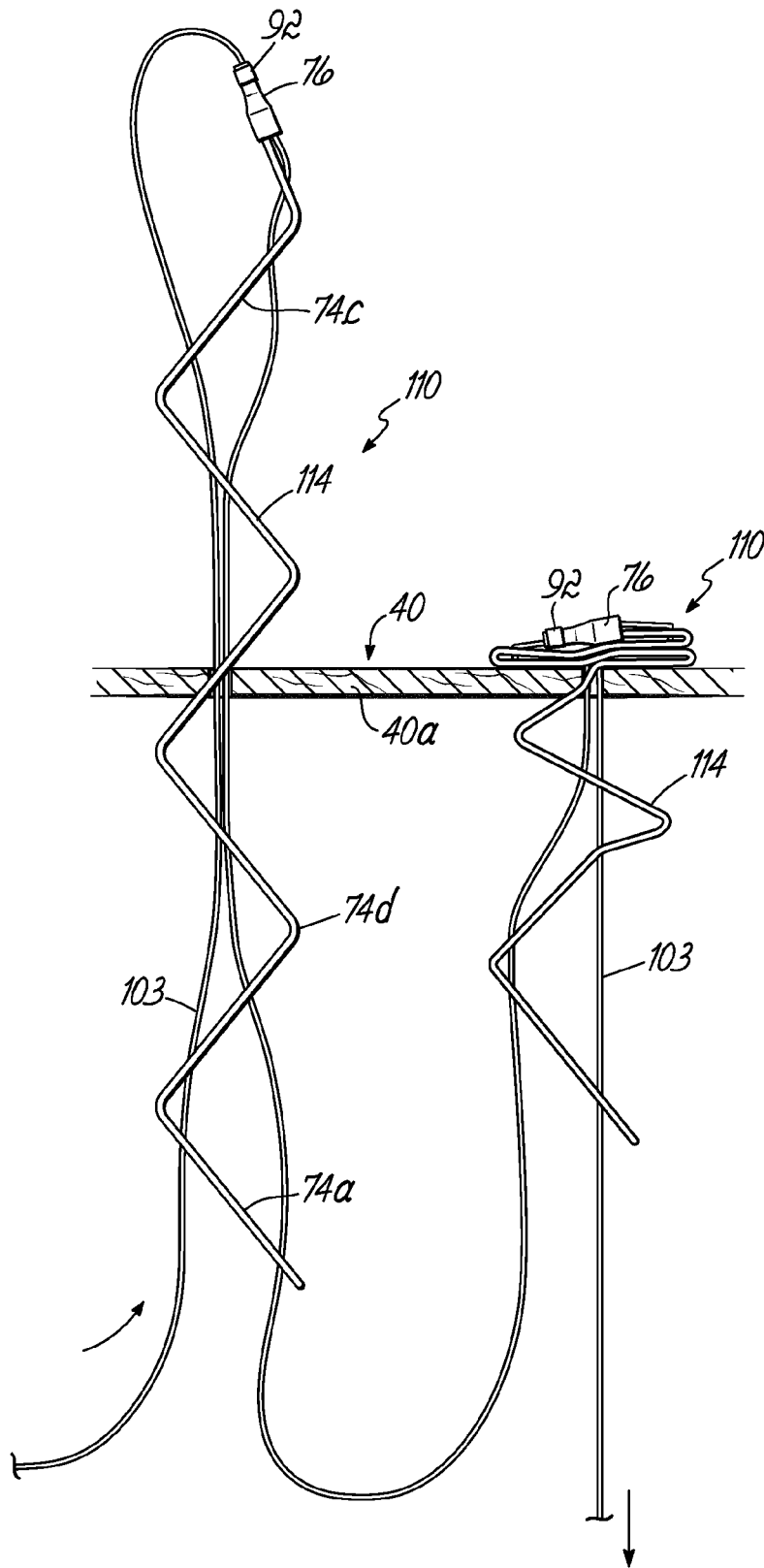

FIG. 9A

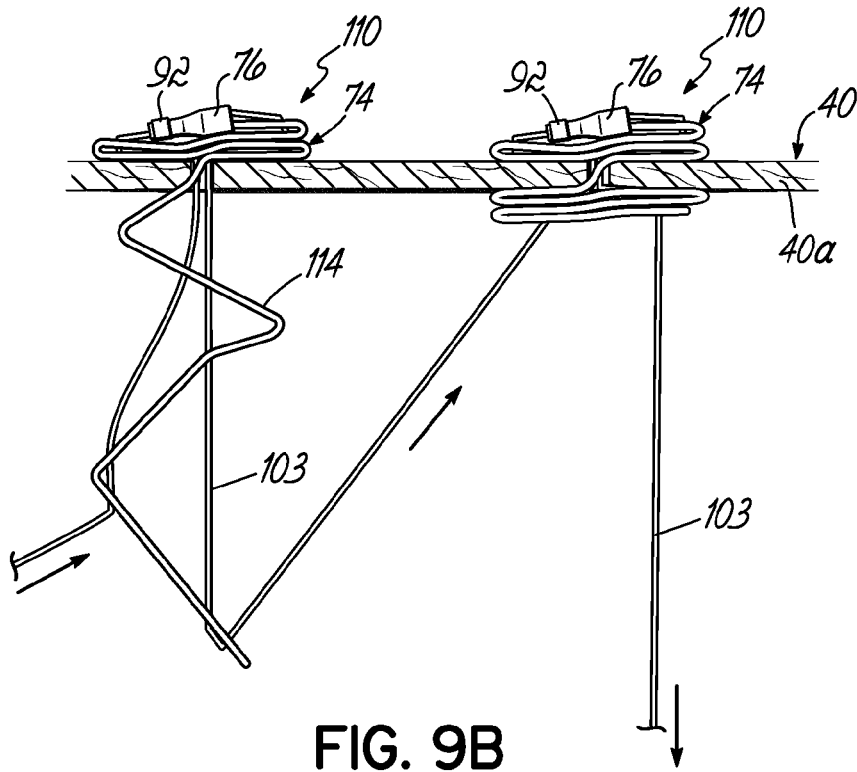

FIG. 9B

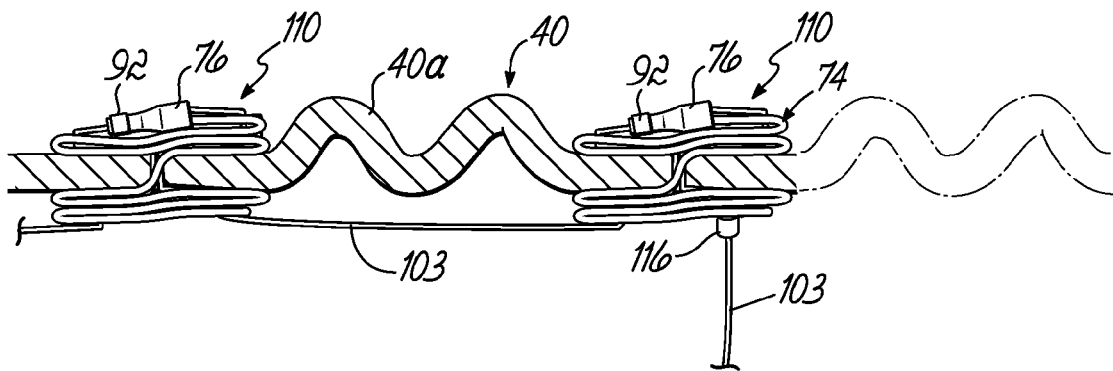
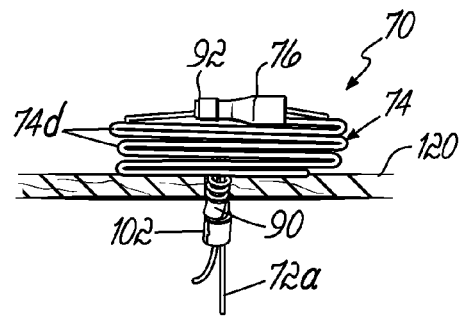
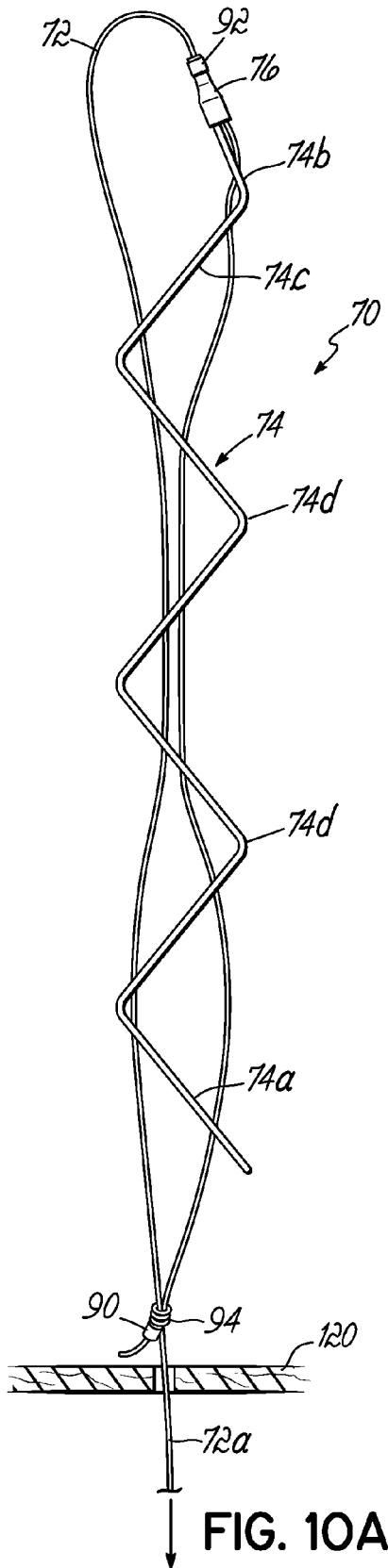

FIG. 9C



1

TISSUE ANCHOR AND ANCHORING SYSTEM

This application is a divisional of U.S. patent application Ser. No. 11/174,951, filed Jul. 5, 2005 (pending), the disclosure of which is hereby incorporated by reference herein.

TECHNICAL FIELD

The present invention generally relates to tissue anchors and, more particularly, anchors and methods of using such anchors to secure an element or otherwise provide an anchor point to biological tissue and/or to secure at least two tissue portions together.

BACKGROUND

Many different surgical procedures require that an anchor be used to either establish a strong point of connection for other securing elements or devices relative to a tissue location in a patient, and/or to secure two or more tissue layers (i.e., portions together). In this regard, the term "anchor", as used herein, is not to be limited to any particular type of tissue fastening or securement application but, rather, encompasses any hard and/or soft tissue-to-tissue securement, tissue-to-device securement, or any other tissue securement application.

One particular area that has received attention in recent years is that of catheter-based surgical procedures. Various tissue anchors have been developed for purposes of deployment and securement with catheter-based technology. However, there are still limitations in current technology. For example, insertion size versus deployment size must be strictly controlled due to the need for catheter diameters to be maintained relatively small. Many catheter-based tissue anchor systems have very specialized uses and are not versatile for use in many different tissue fastening or securement operations.

There is generally a need for a simpler, more versatile tissue anchor which may be deployed and securely fastened to tissue in a catheter-based operation or a non-catheter-based operation.

SUMMARY

In one aspect, the invention provides a tissue anchor comprising a generally flexible anchor member capable of being inserted through tissue and moving between an elongate configuration and a shortened configuration suitable for anchoring against at least one side of the tissue. The anchor member includes a proximal end portion, a distal end portion, and a compressible intermediate portion between the proximal end portion and the distal end portion. A tensioning member is operatively connected to the anchor member such that the anchor member can slide relative to the tensioning member. The tensioning member may be pulled to cause the anchor member to move relative to the tensioning member from the elongate configuration to the shortened configuration. In the shortened configuration, the compressible intermediate portion of the anchor member can compress or shorten and thereby adjust to the thickness of the tissue between the proximal and distal end portions.

In another aspect of the invention, a tissue anchor is provided comprising a flat, generally flexible anchor member capable of movement between an elongate configuration suitable for deployment and a shortened configuration suitable for anchoring against tissue. A tensioning member is opera-

2

tively connected to the anchor member such that the anchor member can slide relative to the tensioning member. The tensioning member is capable of being pulled to cause the anchor member to move relative to the tensioning member from the elongate configuration to the shortened configuration.

In a further aspect of the invention, a tissue anchor is provided comprising a flat anchor member formed from a strip of fabric material and capable of movement between an elongate configuration suitable for deployment and a shortened configuration suitable for anchoring against tissue. A tensioning member is operatively connected to the anchor member such that the anchor member can slide relative to the tensioning member. The tensioning member is capable of being pulled to cause the anchor member to move relative to the tensioning member from the elongate configuration to the shortened configuration. A lock member is provided for securing the anchor member in the shortened configuration.

In a further aspect of the invention, a tissue anchor is provided comprising a flat, generally flexible anchor member capable of being inserted through tissue and moving between an elongate configuration suitable for deployment through a catheter and a shortened configuration suitable for anchoring against the tissue. A tensioning member is operatively connected to the anchor member such that the anchor member may slide relative to the tensioning member. The tensioning member is capable of being pulled to cause the anchor member to move relative to the tensioning member from the elongate configuration to the shortened configuration against the tissue.

In another aspect of the invention, a tissue anchor is provided comprising a flat elongate strip formed from a generally flexible material and having proximal and distal end portions. A tensioning member having first and second ends is operatively connected to the elongate strip such that pulling on the first end of the tensioning member causes the proximal and distal end portions of the elongate strip to move toward each other to a shortened configuration suitable for anchoring against the tissue.

In certain aspects, the anchor member is advantageously formed as a flat, generally flexible strip of material, while in other aspects it need not be a flat strip but may have other shapes, such as tubular, that may or may not be capable of assuming a flat shape. Various optional features may be incorporated into any or all of the various embodiments of the tissue anchor. For example, the tissue anchor may be formed from a material selected from at least one of: natural fibers, synthetic fibers, polymers, and metals. Such materials may be absorbable or nonabsorbable, and may be radiopaque or at least partially radiopaque. The tensioning member may further comprise a suture, or any other suitable flexible, semi-rigid or rigid tensioning member. The tensioning member may include a stop member engaged with the anchor member, such as a knot in the tensioning member, or a separate stop member (e.g., a crimp) engageable with the anchor member. The tensioning member may, for example, extend through the anchor member at multiple locations between the proximal end portion and the distal end portion. Such coupling of the tensioning member and the anchor member may be configured in many different manners depending, for example, on the desired configuration of the anchor member upon pulling the tensioning member and moving the anchor member into the shortened configuration. In one embodiment, at least one fold is formed upon pulling the tensioning member. Multiple folds may be formed in a generally zig-zag or accordion fashion. A lock member may be provided and engageable with the tensioning member to retain the anchor member in

the shortened configuration. The tissue anchor may include at least one radiopaque marker on one or both of the anchor member and the tensioning member. For example, a first radiopaque marker may be located near the proximal end portion when the anchor member is in the shortened configuration and a second radiopaque marker may be located near the distal end portion when the anchor member is in the shortened configuration. The distal end portion of the anchor member may include a relatively more rigid tip as compared to the anchor member and having a reduced width as compared to an adjacent portion of the anchor member. The anchor member itself may be designed in any of numerous manners, including designs that have a uniform width along the length thereof, and designs that have a varying width along the length. Other features may be incorporated such as edge portions that are slightly more rigid than a central area of the anchor member. Entire sections of the anchor member may be relatively rigid as compared to fold line portions thereof while still resulting in a generally flexible anchor member. As necessary, hinge portions, such as living hinges, may be designed into the anchor member to allow for folding or other shortening action of the anchor member. While a tensioning member is specifically disclosed herein for activation purposes (that is, activating the anchor member from the elongate configuration to the shortened configuration), the invention in various combinations may utilize other types of activation, such as compressive activation.

Each of the embodiments of the tissue anchor may be part of a catheter-based anchoring system having a delivery catheter and a suitable deploying device associated with the delivery catheter and operable to extend the anchor member from the delivery catheter. The deploying device may further comprise a deploying catheter at least partially containing the anchor member and at least partially contained within the delivery catheter.

The invention further provides for various methods of anchoring tissue as generally described herein. For example, in one aspect a method of anchoring tissue is provided comprising inserting a generally flexible elongate anchor member through the tissue, and pulling a first end of a tensioning member coupled for sliding movement relative to the first anchor member to draw the proximal and distal end portions toward each other and to compress the intermediate portion into the shortened configuration with at least one of the proximal and distal end portions engaged against the tissue.

In another aspect of the invention, a method of tissue anchoring is provided comprising inserting the generally flexible flat elongate strip having proximal and distal end portions through the tissue, and pulling a first end of a tensioning member operatively connected to the strip to draw the proximal and distal end portions of the strip toward each other into the shortened configuration engaged against the tissue.

In another aspect, a method of tissue anchoring is provided comprising inserting the generally flexible flat elongate strip having proximal and distal end portions through the tissue, and pulling a first end of a tensioning member operatively connected to the strip to configure at least a portion of the strip into a shortened configuration engaged against the tissue.

In each of the embodiments engagement of the anchor member against the tissue may be engagement against opposite sides of at least one tissue layer, or engagement against only one side of at least one tissue layer.

Additional features and advantages of the invention will become readily apparent to those of ordinary skill in the art upon review of the following detailed description of the illustrative embodiments taken in conjunction with the accompanying illustrative figures.

BRIEF DESCRIPTION OF THE DRAWINGS

FIG. 1 is a perspective view of a tissue anchor constructed in accordance with a first embodiment of the invention.

FIG. 2A is a side view of the tissue anchor shown in FIG. 1, with the tissue anchor deployed through a layer of tissue.

FIG. 2B is a side view similar to FIG. 2A, but illustrating the distal portion of the tissue anchor being moved toward the layer of tissue.

FIG. 2C is a side view similar to FIG. 2B, but showing the distal portion fully compressed and engaged against the layer of tissue.

FIG. 2D is a side view similar to FIG. 2C but illustrating the proximal portion of the tissue anchor being moved toward the layer of tissue.

FIG. 2E illustrates the proximal and distal portions of the tissue anchor fully compressed against opposite sides of the layer of tissue.

FIG. 2F is an enlarged cross sectional view illustrating the fully deployed and fastened anchor with a layer of tissue between proximal and distal anchor portions.

FIG. 3 is a side cross sectional view similar to FIG. 2F, but illustrating the fastening of two layers of tissue between the proximal and distal anchor portions.

FIGS. 4A-4F are perspective views illustrating successive steps in an annuloplasty procedure on the mitral valve of a patient utilizing tissue anchors of the first embodiment.

FIGS. 5A-5E are perspective views illustrating a mitral valve annuloplasty procedure utilizing tissue anchors constructed according to a second embodiment of the invention.

FIG. 6 is a side elevational view illustrating the tissue anchor constructed in accordance with the second embodiment.

FIG. 7 is a front view of the elongate strip portion of the anchor.

FIG. 7A is a front elevational view similar to FIG. 7, but illustrating one embodiment of radiopaque markers used on the elongate strip.

FIG. 7B is a front elevational view of an alternative anchor strip having a varying width along its length.

FIG. 7C is a side elevational view of another alternative anchor strip utilizing more rigid fold sections separated by living hinges.

FIGS. 8A-8D are respective side views illustrating a sequence of steps used for securing the tissue anchor of the second embodiment to a layer of tissue.

FIG. 8E is a view similar to FIG. 8D, but illustrating an alternative tip and tensioning member arrangement.

FIGS. 9A-9C are respective side elevational views illustrating an annuloplasty procedure in which two tissue anchors of the second embodiment are daisy-chained together with a single tensioning member to plicate the tissue between the anchors in a more integrated procedure.

FIGS. 10A and 10B are respective side elevational views illustrating the tissue anchor of the second embodiment used to provide an anchor or securement location on only one side of a tissue layer.

DETAILED DESCRIPTION OF ILLUSTRATIVE EMBODIMENTS

Referring first to FIG. 1, a tissue anchor 10 constructed in accordance with a first embodiment of the invention generally includes a tensioning member 12, such as a suture, extending through spaced apart points along a flat elongate strip 14 of flexible material, such as a surgical grade fabric. It will be appreciated that the tensioning member 12 may take other

5

forms other than suture material, such as cable or any other small diameter member having a high enough tensile strength for the intended anchoring use. The elongate strip **14** may also take various forms such as woven or nonwoven fabrics, polymers, metals or other suitable materials or combinations of materials. One or more separate pledgets or other securement members (not shown) may be used in conjunction with the elongate strip **14** for added securement and/or concealing the elongate strip **14** and, for example, thereby inhibiting blood clotting within or adjacent to the folds that will be formed in the strip **14**.

A woven or nonwoven material may contain additional materials, such as threads, beads or other elements that cause at least portions of the strip **14** to be radiopaque. Currently, a surgical grade fabric constructed from polyester, such as Dacron®, is contemplated for use in constructing the strip **14**. One of many possible alternative materials for use in constructing strip **14** is polytetrafluoroethylene (PTFE). Tissue anchor **10** may be partly or wholly formed from materials that are absorbed into the patient's tissue over time, depending on the intended use. The edges and/or other portions of the strip **14** may be suitably modified to prevent fraying, such as by being coated with a material that locks the fibers in place, or otherwise modified in a manner that locks the fibers at least at the edges of the strip **14** in place.

The suture **12** may extend from a proximal end portion **14a** of the fabric strip **14** to a distal end portion **14b** and then loop back through spaced apart points of the fabric strip **14** to the proximal end portion **14a** where a knot **16** or other stop member is located for reasons to be described below. As will become apparent, the suture **12** extends through spaced apart locations along the elongate strip **14** such that tensioning of the suture **12** or other tensioning member will cause the elongate strip **14** to form folded portions **14c** when the tensioning member **12** is placed under tension or pulled. Thus, the elongate strip **14** is activated in this manner between essentially an elongate deployment orientation or configuration, such as shown in FIG. **1**, and a shortened configuration, such as a folded or otherwise shortened configuration having an expanded width in at least one dimension as compared to the elongate deployment configuration. It will be appreciated that the deployment orientation may take on various forms due to the flexible nature of the strip **14**, especially when using a highly flexible fabric or other material. For example, a fabric material or other similarly flexible materials may be folded or otherwise deformed for carrying purposes within a catheter and/or during deployment to a tissue site and then suitably activated at the tissue site.

More specifically referring to FIGS. **2A-2E**, the elongate strip **14** and attached suture **12** are initially inserted through at least one tissue layer **20** as generally shown in FIG. **2A**. One end or portion **12a** of the suture **12** is then pulled and thereby placed under tension. It will be appreciated that, for catheter-based procedures, suture portion **12a** may extend to a location outside the patient's body for pulling or tensioning, or it may be grasped by a suitable mechanism within the catheter and pulled or tensioned. Pulling suture portion **12a** may initially draw the distal portion **14b** of the elongate strip **14** toward the layer of tissue **20** as shown in FIG. **2B**. Once the distal portion **14b** is compressed against the layer of tissue **20**, the proximal portion **14a** begins to be drawn and compressed against a proximal side of the tissue **20** as shown in FIGS. **2C-2E**. This occurs because end **12a** of the suture **12** is being pulled downwardly (as viewed for purposes of discussion in FIGS. **2C-2E**) and, since the suture **12** is looped in a reverse direction through distal end portion **14b** of the elongate strip **14**, the knot **16** at the end of the suture **12** moves upwardly and brings

6

the proximal portion **14a** of the elongate strip **14** with it. In this manner, the proximal portion **14a** of the elongate strip **14** is being folded and drawn along the suture **12** toward the layer of tissue **20** and then firmly compressed against the proximal side of the layer of tissue **20** as shown in FIG. **2E**. As further shown in FIG. **2F**, a suitable locker element, such as a crimp member **22**, a knot or other element may be used to maintain the suture **12** and elongate strip **14** in the positions shown in FIG. **2F** securely anchoring the proximal and distal portions **14a**, **14b** of the elongate strip **14** folded against opposite sides of the tissue **20**.

As further shown in FIG. **3**, the same general procedure may be used to secure two distinct tissue layers **30**, **32** together by initialing extending the elongate strip **14** and tensioning member **12** through at least two layers of tissue **30**, **32**. In this manner, for example, two layers of tissue **30**, **32** may be securely fastened together. This may, for example, involve two entirely different layers and even types of tissue or the same layer of tissue which has been folded over to effectively form two layers (i.e., portions) of tissue.

FIGS. **4A-4E** schematically illustrate an annuloplasty procedure performed on a mitral valve **40** of a heart **42** utilizing tissue anchors **10** as described above in regard to the first embodiment. Performance of the annuloplasty procedure may have many variations, but is generally illustrated by the placement of at least two tissue anchors **10** and securement of the two anchors **10** together, such as with one or more tensioning members **12** therebetween. For an additional illustrative description of catheter-based annuloplasty procedures that may utilize any of the tissue anchors within the scope of the present invention, reference may be made to U.S. patent application Ser. No. 10/948,922, filed on Sep. 24, 2004, assigned to the assignee of the present invention, and the disclosure of which is hereby entirely incorporated by reference herein.

As illustrated in FIG. **4A**, a first tissue anchor **10** is deployed through a catheter device **50** which may, for example, have an inner tubular member **52** or deploying catheter received within an outer tubular member **54** or delivery catheter. The tissue anchor **10** and tensioning member **12** are carried within the inner tubular member **52** and are deployed from a distal end **52a** thereof. To ensure that proper force is applied to penetrate the tissue, tissue anchor **10** may be deployed or extended after the inner tubular member **52** has been inserted through tissue at the annulus **40a** of the mitral valve **40**. This is best illustrated in FIG. **4B**. The inner tubular member **52** is withdrawn from the annulus tissue **40a** of the elongate strip **14**. As previously described, activating (e.g., compression, folding or otherwise shortening) the elongate strip **14** by pulling the suture **12** causes the distal end portion **14b** and then proximal end portion **14a** to be securely compressed and folded against opposite sides of the annulus tissue **40a**. This procedure is repeated at least one additional time to securely fasten an additional tissue anchor **10** at a location spaced from the initial location. For example, the initial location may be at location P2 of the mitral valve annulus **40** while the second location may be spaced on either side of location P2. Catheter device **50** may be inserted into the location of annulus **40a** in various manners, but is shown being inserted downwardly through the aortic valve **53** into the left ventricle **55**, and curving upward toward the mitral valve annulus **40a**.

In the illustrative example shown in FIG. **4E**, three tissue anchors **10** have been deployed and securely fastened to the annulus tissue **40a**. As shown in FIG. **4F** a suture locker **56** may then be deployed and used to maintain relative position

and, therefore, tension between each of three respective tensioning members or sutures 12 associated with the three tissue anchors 10 after the tissue anchors 10 have been pulled closer to each other thereby plicating the tissue 40a between the anchors 10. This essentially shortens the valve annulus 40a and pulls the posterior leaflet 60 toward the anterior leaflet 62 to prevent leakage through the valve 40, i.e., to achieve better coaptation of the posterior and anterior leaflets 60, 62 during systole.

FIGS. 5A-5E illustrate a similar annuloplasty procedure on a mitral valve 40 utilizing a second embodiment of a tissue anchor 70 and a modified method of deployment and activation. In general, the differences between anchor 70 and anchor 10 will be described below with the understanding that all other attributes, options and features associated with anchor 70 may be as described above in connection with anchor 10. As shown in FIG. 5A, in this embodiment a tensioning member 72 is again used to activate a flexible, elongate flat strip 74 having proximal and distal end portions 74a, 74b. Strip 74 includes a tip 76 that is formed or otherwise secured on the distal end portion 74b. The tensioning member 72 and the tip 76 are arranged such that the tensioning member 72 slides relative to the tip 76. More particularly, the tensioning member 72 can be threaded through the tip 76. Tip 76 is made to be relatively rigid as compared to other flexible portions of strip 74 and of smaller diameter than the width of strip 74. Therefore, tip 76 helps to penetrate the annulus tissue 40a as the inner tubular member 52 and the elongate strip 74 are extended through the tissue 40a. A wire 73 may be used to push the tip 76 out of the tubular member 52 at the desired time. The tip 76 may protrude slightly from the inner tubular member 52 as the tissue 40a is penetrated to assist with piercing the tissue 40a. The tip 76 may also assist with forcing distal portion or half 74b of strip 74 into a folded or otherwise shortened configuration. To help prevent the distal portion 74b of the elongate strip from pulling back through the tissue 40a as the inner tubular member 52 is withdrawn from the annulus tissue 40a, the free end of the tensioning member 72 is pulled while the inner tubular member 52 is still penetrated through the tissue 40a and into the left atrium 80 from the left ventricle 55. This forms the distal portion 74b into a folded or otherwise shortened configuration as shown in FIG. 5B. The inner tubular member 52 may then be withdrawn without also withdrawing the elongate flexible strip 74 with it, as shown in FIG. 5C. The proximal portion 74a of the elongate strip 74 is then deployed by pulling the inner tubular member 52 further in a proximal direction, and thereby exposing the full length of strip 74. The tensioning member 72 is pulled or tensioned so as to draw and compress the proximal portion 74a of the elongate strip 74 into a folded, shortened condition against an underside of the annulus tissue 40a as shown in FIG. 5D. As with the previously described annuloplasty procedure using the first embodiment of the tissue anchor 10, this is repeated as many times as necessary to create the necessary number of tissue plications. FIG. 5E illustrates this by way of an exemplary view of three successive tissue anchor securement locations with tissue anchors 70 that may be drawn together and locked in place to achieve and retain the plications as described in connection with FIG. 4F. Such plications reduce or close the gap between the posterior and anterior leaflets 60, 62, during systole.

FIG. 6 is a side elevational view of the tissue anchor 70 as shown and described with respect to the annuloplasty procedure of FIGS. 5A-5E. This embodiment differs from the first embodiment in a number of different manners, in addition to the use of a distal tip 76 for tissue penetration purposes. For example, the elongate strip 74 is somewhat shorter than the

elongate strip 14 utilized in the first embodiment. For example, the strip 74 may be about 40 mm long by about 3 mm wide. Of course, any other desired dimensions and shapes may be used depending on application needs. This may be desirable to achieve a lower profile deployed and fastened configuration with fewer folds that may lead to more versatile applications, lower incidents of blood clotting, easier use, etc. In addition, respective proximal and distal radiopaque bands 90, 92 are secured to the suture 72 at the proximal end portion of the strip 74 and to either the interior or exterior of the distal tip 76. Under a fluoroscope, these bands or other markers 90, 92 will indicate to the surgeon that the anchor 70 has been deployed, activated and fully compressed and/or fastened as necessary during the procedure. The tip 76 itself may alternatively be formed from a radiopaque material. In this second embodiment, the knot 94 formed in the suture 72 or other tensioning member is a slip knot through which another portion of the suture 72 slides during activation of the tissue anchor 70. It will be appreciated that this slip knot 94 may be replaced by another element which serves essentially the same purpose but takes the form, for example, of a small tubular element or other feature similar in function to a slip knot.

As further shown in FIGS. 6 and 7, the tensioning member or suture 72 can advantageously extend through respective fold portions 74c of the elongate strip 74 in essentially an hourglass configuration. Specifically, adjacent portions of the suture 72 located near the proximal and distal end portions 74a, 74b of the strip 74 are spaced farther apart than the adjacent portions of the suture 72 in the middle of the strip 74. As further shown in FIG. 7A, radiopaque markers, such as distinct areas of dots 95, may be used for enabling the surgeon to visualize the folds of the elongate strip 74 during deployment and securement of the elongate strip 74. These dots or other radiopaque markers may be printed on the strip 74. For example, dots 95 or other markers may be formed with a platinum powder base ink or other suitable material that is radiopaque and biologically compatible. This radiopaque material may also add stiffness to the fold sections 74c thereby helping to maintain the fold sections 74c flat and increasing retention force on the tissue. Meanwhile, the fold lines 74d between fold sections 74c can remain highly flexible to create tight radius fold lines. As further shown in FIG. 7, each of the holes 96 that the tensioning member or suture 72 is received through may be marked by circles 98 surrounding each hole 96 or other markers for visualizing purposes during assembly of the tensioning member or suture 72 with the elongate strip 74. Optionally, holes 96 may be eliminated and the suture 72 may be threaded with a needle through the strip 74. One could also, for example, choose different sets of holes 96 along strip 74 for receiving the tensioning member or suture 72 thereby changing the width of the folds and/or number of folds and/or shape of the folds depending on the application needs or desires of the surgeon. The tensioning member or suture 72 may be threaded or otherwise attached along the strip 74 in any number of manners including, for example, x-patterns or other crossing patterns, zig-zag patterns, etc. that may alter the folded or otherwise shortened or compressed footprint of the anchor into various beneficial shapes, such as flower shapes, circular shapes or other rounded shapes, ball shapes or other configurations. Modifications of the manner in which the tensioning member or suture 72 is threaded or otherwise attached along the length of strip 74 may result in higher or lower tensioning force being required to compress the anchor and/or higher or lower friction holding force that may help maintain the anchor in the compressed or shortened configuration. The width of the

elongate strip 74' may be varied along its length, such as by tapering, stepping, or forming an hourglass shape or shapes along the length of the strip 14. For example, as illustrated in FIG. 7B, having proximal and distal end portions 75, 77 of wider dimension than an intermediate or middle portion or portions 79 along the length of strip 74' will allow these wider portions 75, 77 may cover over the more intermediate folded portions 79 and prevent unnecessary contact with adjacent tissue during use. It will be appreciated that like reference numerals are used herein to refer to like elements in all embodiments and reference numerals with prime marks (') or double prime marks (") refer to like elements that have been modified in a manner as described herein or otherwise shown in the associated figure. Strip 74 may have variable stiffness including, for example, a relatively rigid perimeter or relatively rigid edges 74e, 74f (FIG. 7) or intermittent relatively rigid sections 74c" separated by flexible sections such as living hinges 74d" (FIG. 7C) that may aid in folding and securing the elongate strip 74" into a folded condition.

FIGS. 8A-8D illustrate a series of steps for deploying and securely fastening the tissue anchor 70 of the second embodiment to a layer of tissue 100. Generally, as shown in FIG. 8A, the combination of the elongate strip 74 and tensioning member or suture 72 is deployed through the layer of tissue 100. One end or portion 72a of the suture 72 that extends through the slip knot 94 is then pulled. This causes the distal portion 74b of the elongate strip 74 to fold and compress against the distal side of the tissue layer 100. As shown in FIG. 8B, further pulling of the tensioning member 72 causes the slip knot 94 to ride upwardly or distally along the suture 72 and against a proximal portion 74a of the elongate strip 74 thereby folding and compressing the proximal portion 74a against the proximal side of the tissue layer 100 as shown in FIG. 8C. As shown in FIG. 8D, a suitable crimp or locking element 102 may be used to securely lock the slip knot 94 in place relative to the suture or tensioning member segment which extends therethrough. This will lock the entire anchor 70 in place with the respective proximal and distal folded strip portions 74a, 74b securely retaining the tissue layer or layers 100 therebetween. FIG. 8D shows the tip 76 acting as a retainer on top of the distal end portion 74b to assist in holding the distal end portion 74b in place. FIG. 8E shows an alternative in which the tensioning member is threaded through at least one hole 76a more centrally located in the tip. Yet another alternative would be to thread the tensioning member through two centrally located holes instead of through the proximal end of the tip 76 and one centrally located hole 76a as shown in FIG. 8E. These alternatives allow the tip 76 to act more like a "T"-bar with forces acting in a more perpendicular or normal manner relative to the distal end portion 74b of the strip 74.

FIGS. 9A-9C illustrate another alternative embodiment of a plication procedure, for example, for use during annuloplasty on a mitral valve annulus 40a. In this regard, a single tensioning member, such as a suture 103 or other member may be used to deploy, fasten and draw together at least two separate tissue anchors 110. As shown in FIG. 9A, first and second tissue anchors 110 may be respectively deployed at spaced apart locations along the mitral valve annulus 40a. Each tissue anchor 110 includes an elongate strip 114 of flexible material, such as fabric or other material as described above, as well as a single suture 103 or tensioning member extending through each of the elongate strips 114. Upon deployment of the two tissue anchors 110 through the tissue layer 40 at spaced apart locations, the free end of the suture 103 or tensioning member is pulled thereby securely fastening the first tissue anchor 110 as shown in FIGS. 9A and 9B and subsequently securely fastening the second tissue anchor

110 to the annulus tissue 40a. Upon further pulling or tensioning of the suture 103, the tissue anchors 110 will be drawn together to plicate the tissue 40 therebetween as shown in FIG. 9C. A crimp or other locker member 116 may then be used to lock in the desired amount of plication by crimping onto the free end of the suture 103 adjacent to the slip knot 94 of the first tissue anchor 110 as shown in FIG. 9C. The free end of the suture 103 may then be cut to eliminate or reduce the length of the suture tail.

FIGS. 10A and 10B illustrate a tissue anchor 70 of the second embodiment, for example, being used to provide an anchor or securement location on only one side of a tissue layer 120. In this regard, the tissue anchor 70 may be extended entirely through the tissue layer(s) 120. The free end of the suture or tensioning member 72 is then pulled proximally to compress and fold the elongate strip 74 against the distal side of the tissue layer 120 as shown in FIG. 10B. It will be appreciated that activation of strip 74 occurs similarly to the other described embodiments, except that the activated portion (that is, the folded or otherwise shortened portion) is located entirely on one side of the tissue layer 120. As illustrated, the intermediate or middle portion between the proximal and distal end portions of the anchor member shortens to adjust to the amount of tissue contained therebetween (if any) or shortens during the compression process on only one side of the tissue.

While the present invention has been illustrated by a description of various illustrative embodiments and while these embodiments have been described in some detail, it is not the intention of the Applicant to restrict or in any way limit the scope of the appended claims to such detail. Additional advantages and modifications will readily appear to those skilled in the art. The various features of the invention may be used alone or in numerous combinations depending on the needs and preferences of the user. What is claimed is:

What is claimed is:

1. A tissue anchor comprising:

a generally flexible elongate continuous anchor member capable of being inserted through tissue and moving between an elongate configuration and a shortened configuration suitable for anchoring against at least one side of the tissue, said anchor member having a proximal end portion, a distal end portion, and a compressible intermediate portion between said proximal end portion and said distal end portion, and

a tensioning member operatively connected to said anchor member such that said anchor member can slide relative to said tensioning member, the tensioning member extending through the proximal end portion of the generally flexible elongate anchor member, to the distal end portion, and back to an anchor point at the proximal end portion, at least first and second generally parallel portions of the tensioning member and at least a portion of the intermediate portion of the generally flexible elongate anchor member extending through the tissue in a deployed configuration, said tensioning member capable of being pulled to cause said anchor member to move relative to said tensioning member from said elongate configuration to said shortened configuration wherein the compressible intermediate portion can compress and thereby adjust to the thickness of the tissue between the proximal and distal end portions and said anchor member forms at least one fold upon pulling said tensioning member; wherein material of the anchor member is selected to fold on both proximal and distal sides of the tissue in response to a transition to the shortened configuration.

11

2. The tissue anchor of claim 1, wherein said generally flexible elongate anchor member is formed from a material selected from at least one of: natural fibers, synthetic fibers, polymers, and metals.

3. The tissue anchor of claim 2, wherein said tensioning member comprises a suture. 5

4. The tissue anchor of claim 1, wherein said tensioning member comprises a suture.

5. The tissue anchor of claim 1, wherein said tensioning member includes a stop member engageable with said anchor member. 10

6. The tissue anchor of claim 5, wherein said stop member comprises a knot in said tensioning member.

7. The tissue anchor of claim 1, wherein said tensioning member extends through said anchor member at multiple locations between the proximal end portion and the distal end portion. 15

8. The tissue anchor of claim 1, further comprising a lock member engageable with said tensioning member to retain said anchor member in the shortened configuration. 20

9. The tissue anchor of claim 1, further comprising at least one radiopaque marker on at least one of said anchor member and said tensioning member.

10. The tissue anchor of claim 9, further comprising a first radiopaque marker located proximate said proximal end portion when said anchor member is in the shortened configuration and a second radiopaque marker located proximate said distal end portion when said anchor member is in the shortened configuration. 25

11. The tissue anchor of claim 1, wherein said distal end portion includes a relatively rigid tip, said tip being of reduced width relative to an adjacent portion of said anchor member.

12. The tissue anchor of claim 11, wherein said tip acts as a compressive force applying member against the distal end portion of the anchor member when the anchor member is in the shortened configuration. 35

13. The tissue anchor of claim 1, wherein said anchor member varies in width along its length when in the elongate configuration, wherein the proximal and distal end portions of the anchor member have greater width than the intermediate portion to allow the proximal and distal end portions to cover a plurality of folded sections formed in the intermediate portion in the shortened configuration. 40

14. The tissue anchor of claim 1, wherein said anchor member includes an edge portion that extends longitudinally along a side edge of the anchor member and is more rigid than a central area of said anchor member. 45

15. The tissue anchor of claim 1, further comprising: a force applying member configured to bear against the distal end portion of the anchor member when the anchor member is in the shortened configuration. 50

16. A tissue anchor comprising:

a flat, generally flexible elongate continuous anchor member capable of movement between an elongate configuration suitable for deployment and a shortened configuration suitable for anchoring against tissue, said anchor member having a proximal end portion, a distal end portion, and a compressible intermediate portion between said proximal end portion and said distal end portion, wherein said anchor member includes a plurality of fold lines that are spaced along a length of said anchor member and extend transversely across said anchor member, said fold lines defining discrete sections of the anchor member which lie in a stacked orientation in said shortened configuration; and 60

a tensioning member operatively connected to said anchor member such that said anchor member can slide relative 65

12

to said tensioning member, the tensioning member extending through the proximal end portion of the flat, generally flexible elongate member, to the distal end portion, and back to an anchor point at the proximal end portion, at least first and second generally parallel portions of the tensioning member and at least a portion of the intermediate portion of the anchor member extending through the tissue in a deployed configuration, said tensioning member capable of being pulled to cause said anchor member to move relative to said tensioning member from said elongate configuration to said shortened configuration and said anchor member forms at least one fold upon pulling of said tensioning member; wherein material of the anchor member is selected to fold on both proximal and distal sides of the tissue in response to a transition to the shortened configuration.

17. The tissue anchor of claim 16, further comprising: a force applying member configured to bear against the anchor member when the anchor member is in the shortened configuration. 20

18. The tissue anchor of claim 16, wherein the plurality of fold lines comprises a plurality of living-hinges formed in the anchor member.

19. A tissue anchor comprising:

a flat elongate continuous anchor member formed from a strip of fabric material and capable of movement between an elongate configuration suitable for deployment and a shortened configuration suitable for anchoring against tissue, said anchor member having a proximal end portion, a distal end portion, and a compressible intermediate portion between said proximal end portion and said distal end portion, 25

a tensioning member operatively connected to said anchor member such that said anchor member can slide relative to said tensioning member, the tensioning member extending through the proximal end portion of the flat elongate anchor member, to the distal end portion, and back to an anchor point at the proximal end portion, at least first and second generally parallel portions of the tensioning member and at least a portion of the intermediate portion of the anchor member extending through the tissue in a deployed configuration, said tensioning member capable of being pulled to cause said anchor member to move relative to said tensioning member from said elongate configuration to said shortened configuration and said anchor member forms at least one fold upon pulling said tensioning member, and 30

a lock member capable of securing the anchor member in the shortened configuration; wherein material of the anchor member is selected to fold on both proximal and distal sides of the tissue in response to a transition to the shortened configuration. 35

20. A tissue anchor comprising:

a flat, generally flexible elongate continuous anchor member capable of being inserted through tissue and moving between an elongate configuration suitable for deployment through a catheter and a shortened configuration suitable for anchoring against the tissue, said anchor member having a proximal end portion, a distal end portion, and a compressible intermediate portion between said proximal end portion and said distal end portion, and 40

a tensioning member operatively connected to said anchor member such that said anchor member can slide relative to said tensioning member, the tensioning member extending through the proximal end portion of the flat, generally flexible elongate anchor member, to the distal 45

13

end portion, and back to an anchor point at the proximal end portion, at least first and second generally parallel portions of the tensioning member and at least a portion of the intermediate portion of the anchor member extending through the tissue in a deployed configuration, said tensioning member capable of being pulled to cause said anchor member to move relative to said tensioning member from said elongate configuration to said shortened configuration against the tissue and said anchor member forms at least one fold upon pulling said tensioning member;

wherein the anchor member includes a plurality of holes through which the tensioning member passes to allow the tensioning member to be routed in a longitudinal direction in both a first direction and in an opposite second direction along the anchor member, wherein the holes are formed linearly along only a single axis; wherein material of the anchor member is selected to fold on both proximal and distal sides of the tissue in response to a transition to the shortened configuration.

21. The tissue anchor of claim **20**, further comprising: a force applying member configured to bear against the anchor member when the anchor member is in the shortened configuration.

22. A tissue anchor comprising:

a flat elongate continuous strip formed from a generally flexible material and having proximal and distal end portions, and a compressible intermediate portion between said proximal end portion and said distal end portion, and

a tensioning member having first and second ends, the tensioning member extending through the proximal end portion of the flat elongate strip, to the distal end portion, and back to an anchor point at the proximal end portion, at least first and second generally parallel portions of the tensioning member and at least a portion of the intermediate portion of the strip extending through the tissue in a deployed configuration, said tensioning member operatively connected to said elongate strip such that pulling on said first end of said tensioning member causes said proximal and distal end portions of said elongate strip to move toward each other into a shortened configuration suitable for anchoring against the tissue and said elongate strip forms at least one fold upon pulling said tensioning member; wherein material of the anchor member is selected to fold on both proximal and distal sides of the tissue in response to a transition to the shortened configuration.

23. The tissue anchor of claim **22**, further comprising: a force applying member configured to bear against the distal end portion of the anchor member when the anchor member is in the shortened configuration.

24. A tissue anchor comprising:

a generally flexible flat elongate continuous anchor strip capable of being inserted through tissue in an elongate configuration and movable to a shortened, folded configuration suitable for anchoring against at least one side of the tissue, anchor strip having a proximal end portion, a distal end portion, and a compressible intermediate portion between said proximal end portion and said distal end portion, and

an activation member operatively connected to said anchor strip, the activation member extending through the proximal end portion of the generally flexible flat elongate continuous anchor strip, to the distal end portion, and back to an anchor point at the proximal end portion, at least first and second generally parallel portions of the

14

tensioning member and at least a portion of the intermediate portion of the anchor strip extending through the tissue in a deployed configuration, and operable to move the anchor strip from the elongate configuration to the shortened, folded configuration; wherein material of the anchor member is selected to fold on both proximal and distal sides of the tissue in response to a transition to the shortened, folded configuration.

25. The tissue anchor of claim **24**, wherein the shortened, folded configuration further comprises a zig-zag fold pattern.

26. The tissue anchor of claim **24**, further comprising: a force applying member configured to bear against the anchor strip when the anchor strip is in the shortened, folded configuration.

27. A tissue anchoring system, comprising:

a delivery catheter,

a generally flexible elongate continuous anchor member capable of being inserted through tissue and moving between an elongate configuration and a shortened configuration suitable for anchoring against at least one side of the tissue, said anchor member having a proximal end portion, a distal end portion, and a compressible intermediate portion between said proximal end portion and said distal end portion, and a deploying device operatively associated with said delivery catheter and operable to extend the anchor member from said delivery catheter, and

a tensioning member operatively connected to said anchor member such that said anchor member can slide relative to said tensioning member, the tensioning member extending through the proximal end portion of the generally flexible elongate anchor member, to the distal end portion, and back to an anchor point at the proximal end portion, at least first and second generally parallel portions of the tensioning member and at least a portion of the intermediate portion of the generally flexible elongate anchor member extending through the tissue in a deployed configuration, said tensioning member capable of being pulled to cause said anchor member to move relative to said tensioning member from said elongate configuration to said shortened configuration wherein the compressible intermediate portion can compress and thereby adjust to the thickness of the layer of tissue between the proximal and distal end portions and said anchor member forms at least one fold upon pulling said tensioning member;

wherein said anchor member includes a plurality of fold lines that are spaced along a length of said anchor member and extend transversely across said anchor member, said fold lines defining discrete sections of the anchor member which lie in a stacked orientation in said shortened configuration; wherein material of the anchor member is selected to fold on both proximal and distal sides of the tissue in response to a transition to the shortened configuration.

28. The system of claim **27**, wherein said deploying device further comprises a deploying catheter at least partially containing said anchor member and at least partially contained within said delivery catheter.

29. The system of claim **27**, wherein said anchor member is formed from a material selected from at least one of: natural fibers, synthetic fibers, polymers, and metals.

30. The system of claim **29**, wherein said tensioning member comprises a suture.

31. The system of claim **27**, wherein said tensioning member comprises a suture.

15

32. The system of claim 27, wherein said tensioning member includes a stop member engageable with said anchor member.

33. The system of claim 32, wherein said stop member comprises a knot in said tensioning member.

34. The system of claim 27, wherein said tensioning member extends through said anchor member at multiple locations between the proximal end portion and the distal end portion.

35. The system of claim 27, further comprising a lock member engageable with said tensioning member to retain said anchor member in the shortened configuration.

36. The system of claim 27, further comprising at least one radiopaque marker on at least one of said anchor member and said tensioning member.

37. The system of claim 36, further comprising a first radiopaque marker located proximate said proximal end portion when said anchor member is in the shortened configuration and a second radiopaque marker located proximate said distal end portion when said anchor member is in the shortened configuration.

38. The system of claim 27, wherein said distal end portion includes a relatively rigid tip, said tip being of reduced width relative to an adjacent portion of said anchor member.

39. The system of claim 38, wherein said tip acts as a compressive force applying member against the distal end portion of the anchor member when the anchor member is in the shortened configuration.

40. The system of claim 27, wherein said anchor member varies in width along its length when in the elongate configuration.

41. The system of claim 27, wherein said anchor member includes an edge portion that is more rigid than a central area of said anchor member.

42. The tissue anchoring system of claim 27, further comprising: a force applying member configured to bear against the distal end portion of the anchor member when the anchor member is in the shortened configuration.

43. A tissue anchoring system, comprising:

a first generally flexible continuous anchor member capable of being inserted through tissue and moving between an elongate configuration and a shortened configuration suitable for anchoring against at least one side of the tissue, said anchor member having a proximal end portion, a distal end portion, and a compressible intermediate portion between said proximal end portion and said distal end portion,

a second generally flexible continuous anchor member capable of being inserted through the tissue and moving between an elongate configuration and a shortened configuration suitable for anchoring against at least one side of the tissue, said second anchor member having a proximal end portion, a distal end portion, and a compressible intermediate portion between said proximal end portion and said distal end portion, and

a coupling structure operatively connecting said first and second anchor members, the coupling structure comprising at least one tensioning member operatively connected to said first and second anchor members, the tensioning member extending through the proximal end portion of the first anchor member and travels in a first direction, to the distal end portion, and then extends in an opposite second direction back to the proximal end portion of the first anchor member and then extends through the proximal end portion of the second anchor member and travels in the first direction to the distal end portion of the second anchor member and then extends in the opposite second direction back to the proximal end por-

16

tion of the second anchor member, at least first and second portions of the tensioning member and at least a portion of the intermediate portion of the at least one of the first and second anchor members extending through the tissue in a deployed configuration, said tensioning member capable of being pulled to cause the least one of said first and second anchor members to move relative to said tensioning member from said elongate configuration to said shortened configuration wherein the compressible intermediate portion can compress and thereby adjust to the thickness of the layer of tissue between the proximal and distal end portions and the least one of said first and second anchor members forms at least one fold upon pulling said tensioning member; wherein material of the anchor member is selected to fold on both proximal and distal sides of the tissue in response to a transition to the shortened configuration.

44. The system of claim 43, wherein said tensioning member comprises a suture.

45. The system of claim 43, further comprising: a lock member engageable with said at least one tensioning member to retain said first and second anchor members in their respective shortened configurations.

46. The system of claim 43, further comprising: a delivery catheter, and a deploying device operatively associated with said delivery catheter and operable to extend at least one of the first and second anchor members from said delivery catheter.

47. The system of claim 46, wherein said deploying device comprises a deploying catheter at least partially containing said anchor member and at least partially contained within said delivery catheter.

48. The system of claim 43, wherein said anchor member is formed from a material selected from at least one of: natural fibers, synthetic fibers, polymers, and metals.

49. The system of claim 43, further comprising a stop member engageable with said anchor member.

50. The system of claim 43, wherein said first and second anchor members are configured such that said first and second anchor member each can form at least one fold in said compressible intermediate portion.

51. The system of claim 43, further comprising at least one radiopaque marker on at least one of said first anchor member, said second anchor member, or said coupling structure.

52. The system of claim 43, wherein said distal end portions of said first and second anchor members each includes a relatively rigid tip, said tips being of reduced widths relative to adjacent portions of said first and second anchor members.

53. The system of claim 52, wherein said tips act as compressive force applying members against the distal end portions of the respective first and second anchor members when the first and second anchor members are in their shortened configurations.

54. The tissue anchoring system of claim 43 further comprising:

a first force applying member configured to bear against the distal end portion of the first anchor member when the first anchor member is in the shortened configuration, and

a second force applying member configured to bear against the distal end portion of the second anchor member when the second anchor member is in the shortened configuration.

55. The system of claim 43, wherein the first and second anchors are disposed side-by-side in spaced relationship.

17

56. The system of claim 43, wherein the distal end portions of each of the first and second anchors are disposed on one side of the tissue and the proximal end portions of the first and second anchors are disposed on an opposite side of the tissue.

57. A tissue anchor capable of being inserted through tissue for anchoring on both a proximal side and a distal side of the tissue, comprising:

a generally flexible elongate continuous anchor member having a proximal end portion, a distal end portion, and an intermediate portion, the anchor member being comprising a material capable of transitioning between an elongate configuration and a shortened configuration,

wherein in the shortened configuration the anchor member defines a plurality of folds, the anchor member having a length sufficient to define at least one fold on each of the proximal side and the distal side of the tissue with at least a portion of the intermediate portion extending through the tissue in a deployed condition; and

a tensioning member operatively connected to the anchor member such that the anchor member slides relative to said tensioning member under an external force, the tensioning member extending through the proximal end

18

portion of the generally flexible elongate anchor member, to the distal end portion, and back to an anchor point at the proximal end portion,

wherein the tensioning member is pullable to cause the anchor member to move relative to said tensioning member to transition the anchor member from the elongate configuration to the shortened configuration,

wherein the material of the anchor member is selected to fold on both the proximal and distal sides of the tissue in response to the transition to the shortened configuration, and

wherein at least first and second generally parallel portions of the tensioning member extend through the tissue adjacent one folded section of the intermediate portion and extend in a longitudinal direction along one side of the intermediate portion, wherein the one folded section has a first end portion that lies along the proximal side of the tissue and a second end portion that lies along the distal side of the tissue and passes through the tissue at a location between the first and second end portions of the one folded section.

* * * * *