



(12) **United States Patent**  
**Sugimoto et al.**

(10) **Patent No.:** **US 10,695,046 B2**  
(45) **Date of Patent:** **\*Jun. 30, 2020**

(54) **TISSUE ANCHOR AND ANCHORING SYSTEM**

(71) Applicant: **Edwards Lifesciences Corporation**, Irvine, CA (US)

(72) Inventors: **Hiroatsu Sugimoto**, Cambridge, MA (US); **Aaron M. Call**, Mesa, AZ (US); **Karl R. Leinsing**, Dover, NH (US)

(73) Assignee: **Edwards Lifesciences Corporation**, Irvine, CA (US)

(\* ) Notice: Subject to any disclaimer, the term of this patent is extended or adjusted under 35 U.S.C. 154(b) by 179 days.  
This patent is subject to a terminal disclaimer.

(21) Appl. No.: **15/680,742**

(22) Filed: **Aug. 18, 2017**

(65) **Prior Publication Data**

US 2018/0028171 A1 Feb. 1, 2018

**Related U.S. Application Data**

(60) Continuation of application No. 14/581,264, filed on Dec. 23, 2014, now Pat. No. 9,814,454, which is a (Continued)

(51) **Int. Cl.**  
**A61B 17/04** (2006.01)  
**A61B 17/00** (2006.01)

(52) **U.S. Cl.**  
CPC .... **A61B 17/0401** (2013.01); **A61B 17/00234** (2013.01); **A61B 17/0469** (2013.01); (Continued)

(58) **Field of Classification Search**  
CPC ..... A61B 17/0469; A61B 17/0487; A61B 2017/0496; A61B 17/00234; A61B 17/0401  
See application file for complete search history.

(56) **References Cited**  
U.S. PATENT DOCUMENTS

2,143,910 A 1/1939 Didusch  
3,604,488 A 9/1971 Wishart et al.  
(Continued)

FOREIGN PATENT DOCUMENTS

EP 1016377 7/2000  
EP 1034753 A1 9/2000  
(Continued)

OTHER PUBLICATIONS

Cardiac Surgery Renaissance, Anatomical Landscape; Composite Profile of CABG and Valve Procedures, Apr. 25, 1996, Cardiology Roundtable Interviews.

(Continued)

*Primary Examiner* — Gregory A Anderson  
(74) *Attorney, Agent, or Firm* — Thomas C. Richardson

(57) **ABSTRACT**

A tissue anchor includes an anchor member formed from a generally flexible material. An activation member, which may be a tensioning member, causes proximal and distal end portions of the anchor member to move toward each other into a shortened configuration suitable for anchoring against the tissue. The tissue anchor can optionally be deployed and activated using a catheter device.

**19 Claims, 15 Drawing Sheets**



**Related U.S. Application Data**

continuation of application No. 12/273,670, filed on Nov. 19, 2008, now Pat. No. 8,951,286, which is a division of application No. 11/174,951, filed on Jul. 5, 2005, now Pat. No. 8,951,285.

**(52) U.S. Cl.**

CPC . *A61B 17/0487* (2013.01); *A61B 2017/00243* (2013.01); *A61B 2017/00783* (2013.01); *A61B 2017/0406* (2013.01); *A61B 2017/048* (2013.01); *A61B 2017/0417* (2013.01); *A61B 2017/0419* (2013.01); *A61B 2017/0458* (2013.01); *A61B 2017/0464* (2013.01); *A61B 2017/0496* (2013.01)

**(56)****References Cited**

## U.S. PATENT DOCUMENTS

3,656,185	A	4/1972	Carpentier	5,429,131	A	7/1995	Scheinman et al.
3,674,014	A	7/1972	Tillander	5,449,368	A	9/1995	Kuzmak
3,794,041	A	2/1974	Frei et al.	5,450,860	A	9/1995	O'Connor
3,840,018	A	10/1974	Heifetz	5,452,513	A	9/1995	Zinnbauer et al.
3,841,521	A	10/1974	Jarvik	5,464,023	A	11/1995	Viera
3,881,366	A	5/1975	Bradley et al.	5,464,404	A	11/1995	Abela et al.
3,898,701	A	8/1975	La Russa	5,474,518	A	12/1995	Fairer Velazquez
3,959,960	A	6/1976	Santos	5,477,856	A	12/1995	Lundquist
3,986,493	A	10/1976	Hendren, III	5,545,178	A	8/1996	Kensley et al.
3,995,619	A	12/1976	Glatzer	5,565,122	A	10/1996	Zinnbauer et al.
4,042,979	A	8/1977	Angell	5,571,215	A	11/1996	Sterman et al.
4,055,861	A	11/1977	Carpentier et al.	5,593,424	A	1/1997	Northrup
4,118,805	A	10/1978	Reimels	5,601,572	A	2/1997	Middleman et al.
4,214,349	A	7/1980	Munch	5,607,471	A	3/1997	Seguin et al.
4,258,705	A	3/1981	Sorensen et al.	5,623,943	A	4/1997	Hackett et al.
4,261,342	A	4/1981	Aranguren Duo	5,626,590	A	5/1997	Wilk
4,290,151	A	9/1981	Massana	5,626,609	A	5/1997	Zvenyatsky et al.
4,369,787	A	1/1983	Lasner et al.	5,640,955	A	6/1997	Ockuly et al.
4,434,828	A	3/1984	Trincia	5,643,317	A	7/1997	Pavcnik et al.
4,473,928	A	10/1984	Johnson	5,662,681	A	9/1997	Nash
4,489,446	A	12/1984	Reed	5,669,919	A	9/1997	Sanders et al.
4,532,926	A	8/1985	O'Holia	5,674,279	A	10/1997	Wright et al.
4,602,911	A	7/1986	Ahmadi et al.	5,676,653	A	10/1997	Taylor et al.
4,625,727	A	12/1986	Leiboff	5,682,906	A	11/1997	Sterman et al.
4,712,549	A	12/1987	Peters et al.	5,683,402	A	11/1997	Cosgrove et al.
4,778,468	A	10/1988	Hunt et al.	5,690,656	A	11/1997	Cope et al.
4,809,713	A	3/1989	Grayzel	5,702,397	A	12/1997	Goble
4,917,698	A	4/1990	Carpentier et al.	5,702,398	A	12/1997	Tarabishy
4,945,912	A	8/1990	Langberg	5,706,827	A	1/1998	Ehr et al.
4,961,738	A	10/1990	Mackin	5,709,695	A	1/1998	Northrup, III
5,016,353	A	5/1991	Iten	5,716,367	A	2/1998	Koike et al.
5,041,129	A	8/1991	Hayhurst et al.	5,716,370	A	2/1998	Williamson, IV et al.
5,041,130	A	8/1991	Cosgrove et al.	5,716,397	A	2/1998	Myers
5,042,707	A	8/1991	Taheri	5,716,399	A	2/1998	Love
5,061,277	A	10/1991	Carpentier et al.	5,728,116	A	3/1998	Rosenman
5,064,431	A	11/1991	Gilbertson et al.	5,730,150	A	3/1998	Peppel et al.
5,104,407	A	4/1992	Lam et al.	5,749,371	A	5/1998	Zadini et al.
5,108,420	A	4/1992	Marks	5,776,080	A	7/1998	Thome et al.
5,123,914	A	6/1992	Cope	5,776,189	A	7/1998	Khalid
5,171,232	A	12/1992	Castillo et al.	5,782,844	A	7/1998	Yoon et al.
5,171,259	A	12/1992	Inoue	5,797,939	A	8/1998	Yaan
5,192,302	A	3/1993	Kensley et al.	5,810,882	A	9/1998	Bolduc et al.
5,201,880	A	4/1993	Wright et al.	5,813,996	A	9/1998	St. Germain et al.
5,203,777	A	4/1993	Lee	5,824,066	A	10/1998	Gross
5,258,008	A	11/1993	Wilk	5,827,300	A	10/1998	Fleega
5,300,034	A	4/1994	Behnke et al.	5,829,447	A	11/1998	Stevens et al.
5,304,190	A	4/1994	Reckelhoff et al.	5,830,221	A	11/1998	Stein et al.
5,306,234	A	4/1994	Johnson	5,830,224	A	11/1998	Cohn et al.
5,306,296	A	4/1994	Wright et al.	5,843,120	A	12/1998	Israel et al.
5,325,845	A	7/1994	Adair	5,851,185	A	12/1998	Berns
5,337,736	A	8/1994	Reddy	5,855,614	A	1/1999	Stevens et al.
5,346,498	A	9/1994	Greelis et al.	5,860,920	A	1/1999	McGee et al.
5,360,444	A	11/1994	Kusuhara	5,868,733	A	2/1999	Ockuly et al.
5,364,365	A	11/1994	Wortrich	5,876,373	A	3/1999	Giba et al.
5,364,393	A	11/1994	Auth et al.	5,879,366	A	3/1999	Shaw
5,383,852	A	1/1995	Stevens-Wright	5,888,240	A	3/1999	Carpentier et al.
				5,906,579	A	5/1999	Vander Salm et al.
				5,911,720	A	6/1999	Bourne et al.
				5,928,224	A	7/1999	Laufer
				5,931,818	A	8/1999	Werp et al.
				5,935,098	A	8/1999	Blaisdell et al.
				5,944,738	A	8/1999	Amplatz et al.
				5,957,953	A	9/1999	DiPoto et al.
				5,961,440	A	10/1999	Schweich, Jr. et al.
				5,961,539	A	10/1999	Northrup, III et al.
				5,980,515	A	11/1999	Tu
				5,984,939	A	11/1999	Yaan
				5,984,959	A	11/1999	Robertson et al.
				6,015,414	A	1/2000	Werp et al.
				6,027,514	A	2/2000	Stine et al.
				6,042,554	A	3/2000	Rosenman et al.
				6,042,581	A	3/2000	Ryan et al.
				6,045,497	A	4/2000	Schweich, Jr. et al.
				6,050,472	A	4/2000	Shibata
				6,050,936	A	4/2000	Schweich, Jr. et al.
				6,059,715	A	5/2000	Schweich, Jr. et al.
				6,068,637	A	5/2000	Popov et al.
				6,068,648	A	5/2000	Cole et al.
				6,071,292	A	6/2000	Makower et al.

(56)

## References Cited

## U.S. PATENT DOCUMENTS

6,074,341	A	6/2000	Anderson et al.	6,554,845	B1	4/2003	Fleenor et al.
6,074,401	A	6/2000	Gardiner et al.	6,554,852	B1	4/2003	Oberlander
6,074,417	A	6/2000	Peredo	6,562,019	B1	5/2003	Sell
6,080,182	A	6/2000	Shaw et al.	6,564,805	B2	5/2003	Garrison et al.
6,086,582	A	7/2000	Altman et al.	6,565,562	B1	5/2003	Shah et al.
6,099,460	A	8/2000	Denker	6,565,603	B2	5/2003	Cox
6,102,945	A	8/2000	Campbell	6,569,198	B1	5/2003	Wilson et al.
6,106,550	A	8/2000	Magovern et al.	6,579,297	B2	6/2003	Bicek et al.
6,110,200	A	8/2000	Hinnenkamp	6,589,160	B2	7/2003	Schweich, Jr. et al.
6,113,611	A	9/2000	Allen et al.	6,589,208	B2	7/2003	Ewers et al.
6,126,647	A	10/2000	Posey et al.	6,592,593	B1	7/2003	Parodi et al.
6,132,390	A	10/2000	Cookston et al.	6,594,517	B1	7/2003	Nevo
RE36,974	E	11/2000	Bonutti	6,596,014	B2	7/2003	Levinson et al.
6,143,024	A	11/2000	Campbell et al.	6,602,288	B1	8/2003	Cosgrove et al.
6,159,234	A	12/2000	Bonutti et al.	6,602,289	B1	8/2003	Colvin et al.
6,159,240	A	12/2000	Sparer et al.	6,613,078	B1	9/2003	Barone
6,162,168	A	12/2000	Schweich, Jr. et al.	6,613,079	B1	9/2003	Wolinsky et al.
6,165,119	A	12/2000	Schweich, Jr. et al.	6,619,291	B2	9/2003	Hlavka et al.
6,165,120	A	12/2000	Schweich, Jr. et al.	6,626,899	B2	9/2003	Houser et al.
6,165,183	A	12/2000	Kuehn et al.	6,626,917	B1	9/2003	Craig
6,173,199	B1	1/2001	Gabriel	6,626,919	B1	9/2003	Swanstrom
6,174,332	B1	1/2001	Loch et al.	6,626,930	B1	9/2003	Allen et al.
6,183,411	B1	2/2001	Mortier et al.	6,629,534	B1	10/2003	St. Goar et al.
6,187,040	B1	2/2001	Wright	6,629,921	B1	10/2003	Schweich, Jr. et al.
6,190,353	B1	2/2001	Makower et al.	6,651,671	B1	11/2003	Donlon et al.
6,197,017	B1	3/2001	Brock et al.	6,652,556	B1	11/2003	VanTassel et al.
6,206,895	B1	3/2001	Levinson	6,655,386	B1	12/2003	Makower et al.
6,210,347	B1	4/2001	Forsell	6,656,221	B2	12/2003	Taylor et al.
6,210,432	B1	4/2001	Solem et al.	6,669,687	B1	12/2003	Saadat
6,217,610	B1	4/2001	Carpentier et al.	6,669,707	B1	12/2003	Swanstrom et al.
6,231,587	B1	5/2001	Makower	6,676,702	B2	1/2004	Mathis
6,231,602	B1	5/2001	Carpentier et al.	6,682,558	B2	1/2004	Tu et al.
6,251,092	B1	6/2001	Qin et al.	6,689,125	B1	2/2004	Keith et al.
6,267,781	B1	7/2001	Tu	6,689,164	B1	2/2004	Sequin
6,269,819	B1	8/2001	Oz et al.	6,695,866	B1	2/2004	Kuehn et al.
6,285,903	B1	9/2001	Rosenthal et al.	6,699,263	B2	3/2004	Cope
6,287,317	B1	9/2001	Makower et al.	6,702,825	B2	3/2004	Frazier et al.
6,296,656	B1	10/2001	Bolduc et al.	6,702,826	B2	3/2004	Liddicoat et al.
6,298,257	B1	10/2001	Hall et al.	6,702,846	B2	3/2004	Mikus et al.
6,306,133	B1	10/2001	Tu et al.	6,706,065	B2	3/2004	Langberg et al.
6,312,447	B1	11/2001	Grimes	6,709,385	B2	3/2004	Forsell
6,315,784	B1	11/2001	Djurovic	6,709,456	B2	3/2004	Langberg et al.
6,319,263	B1	11/2001	Levinson	6,711,444	B2	3/2004	Koblish
6,319,281	B1	11/2001	Patel	6,718,985	B2	4/2004	Hlavka et al.
6,328,746	B1	12/2001	Gambale	6,719,786	B2	4/2004	Ryan et al.
6,332,089	B1	12/2001	Acker et al.	6,723,038	B1	4/2004	Schroeder et al.
6,332,893	B1	12/2001	Mortier et al.	6,726,716	B2	4/2004	Marquez
6,352,543	B1	3/2002	Cole	6,726,717	B2	4/2004	Alfieri et al.
6,355,030	B1	3/2002	Aldrich et al.	6,730,112	B2	5/2004	Levinson
6,361,559	B1	3/2002	Houser et al.	6,730,121	B2	5/2004	Ortiz et al.
6,368,348	B1	4/2002	Gabbay	6,733,509	B2	5/2004	Nobles et al.
6,385,472	B1	5/2002	Hall et al.	6,736,808	B1	5/2004	Motamedi et al.
6,401,720	B1	6/2002	Stevens et al.	6,746,472	B2	6/2004	Frazier et al.
6,402,680	B2	6/2002	Mortier et al.	6,749,630	B2	6/2004	McCarthy et al.
6,402,760	B1	6/2002	Williamson, IV et al.	6,752,813	B2	6/2004	Goldfarb et al.
6,402,781	B1	6/2002	Langberg et al.	6,764,310	B1	7/2004	Ichihashi et al.
6,406,420	B1	6/2002	McCarthy et al.	6,764,500	B1	7/2004	Muijs Van De Moer et al.
6,406,493	B1	6/2002	Tu et al.	6,764,510	B2	7/2004	Vidlund et al.
6,419,696	B1	7/2002	Ortiz et al.	6,764,810	B2	7/2004	Ma et al.
6,447,522	B2	9/2002	Gambale et al.	6,769,434	B2	8/2004	Liddicoat et al.
6,451,054	B1	9/2002	Stevens	6,770,083	B2	8/2004	Seguin
6,458,076	B1	10/2002	Pruitt	6,786,924	B2	9/2004	Ryan et al.
6,461,366	B1	10/2002	Seguin	6,786,925	B1	9/2004	Schoon et al.
6,470,892	B1	10/2002	Forsell	6,790,231	B2	9/2004	Liddicoat et al.
6,500,184	B1	12/2002	Chan et al.	6,793,618	B2	9/2004	Schweich, Jr. et al.
6,503,274	B1	1/2003	Howanec, Jr. et al.	6,797,001	B2	9/2004	Mathis et al.
6,524,303	B1	2/2003	Garibaldi	6,797,002	B2	9/2004	Spence et al.
6,524,338	B1	2/2003	Gundry	6,802,319	B2	10/2004	Stevens et al.
6,530,952	B2	3/2003	Vesely	6,805,710	B2	10/2004	Bolling et al.
6,533,772	B1	3/2003	Sherts et al.	6,805,711	B2	10/2004	Quijano et al.
6,537,198	B1	3/2003	Vidlund et al.	6,855,126	B2	2/2005	Flinchbaugh
6,537,314	B2	3/2003	Langberg et al.	6,858,039	B2	2/2005	McCarthy
6,542,766	B2	4/2003	Hall et al.	6,866,673	B2	3/2005	Oren et al.
6,544,230	B1	4/2003	Flaherty et al.	6,884,250	B2	4/2005	Monassevitch et al.
6,547,801	B1	4/2003	Dargent et al.	6,893,459	B1	5/2005	Macoviak
				6,908,478	B2	6/2005	Alferness et al.
				6,908,482	B2	6/2005	McCarthy et al.
				6,913,608	B2	7/2005	Liddicoat et al.
				6,918,917	B1	7/2005	Nguyen et al.

(56)

## References Cited

## U.S. PATENT DOCUMENTS

6,921,407	B2	7/2005	Nguyen et al.	7,562,660	B2	7/2009	Saadat
6,923,823	B1	8/2005	Bartlett et al.	7,563,267	B2	7/2009	Goldfarb et al.
6,926,730	B1	8/2005	Nguyen et al.	7,563,273	B2	7/2009	Goldfarb et al.
6,942,694	B2	9/2005	Liddicoat et al.	7,569,062	B1	8/2009	Kuehn et al.
6,945,978	B1	9/2005	Hyde	7,585,321	B2	9/2009	Cribier
6,960,217	B2	11/2005	Bolduc	7,588,582	B2	9/2009	Starksen et al.
6,964,683	B2	11/2005	Kowalsky et al.	7,591,826	B2	9/2009	Alferness et al.
6,964,684	B2	11/2005	Ortiz et al.	7,604,646	B2	10/2009	Goldfarb et al.
6,964,686	B2	11/2005	Gordon	7,608,091	B2	10/2009	Goldfarb et al.
6,976,995	B2	12/2005	Mathis et al.	7,608,103	B2	10/2009	McCarthy
6,986,775	B2	1/2006	Morales et al.	7,625,403	B2	12/2009	Krivoruchko
6,989,028	B2	1/2006	Lashinski et al.	7,632,303	B1	12/2009	Stalker et al.
6,997,951	B2	2/2006	Solem et al.	7,635,329	B2	12/2009	Goldfarb et al.
7,004,176	B2	2/2006	Lau	7,635,386	B1	12/2009	Gammie
7,004,958	B2	2/2006	Adams et al.	7,655,015	B2	2/2010	Goldfarb et al.
7,007,798	B2	3/2006	Happonen et al.	7,666,204	B2	2/2010	Thornton et al.
7,011,669	B2	3/2006	Kimblad	7,682,319	B2	3/2010	Martin et al.
7,011,682	B2	3/2006	Lashinski et al.	7,682,369	B2	3/2010	Seguin
7,018,406	B2	3/2006	Seguin et al.	7,686,822	B2	3/2010	Shayani
7,037,334	B1	5/2006	Hlavka et al.	7,699,892	B2	4/2010	Rafiee et al.
7,077,850	B2	7/2006	Kortenbach	7,704,269	B2	4/2010	St. Goar et al.
7,077,862	B2	7/2006	Vidlund et al.	7,704,277	B2	4/2010	Zakay et al.
7,087,064	B1	8/2006	Hyde	7,722,666	B2	5/2010	Lafontaine
7,101,395	B2	9/2006	Tremulis et al.	7,731,732	B2	6/2010	Ken
7,101,396	B2	9/2006	Artof et al.	7,736,388	B2	6/2010	Goldfarb et al.
7,112,207	B2	9/2006	Allen et al.	7,748,389	B2	7/2010	Salahieh et al.
7,115,110	B2	10/2006	Frazier et al.	7,749,250	B2	7/2010	Stone et al.
7,118,595	B2	10/2006	Ryan et al.	7,753,924	B2	7/2010	Starksen et al.
7,125,421	B2	10/2006	Tremulis et al.	7,758,632	B2	7/2010	Hojeibane et al.
7,150,737	B2	12/2006	Purdy et al.	7,771,455	B2	8/2010	Ken
7,159,593	B2	1/2007	McCarthy et al.	7,780,726	B2	8/2010	Seguin
7,166,127	B2	1/2007	Spence et al.	7,871,368	B2	1/2011	Zollinger et al.
7,169,187	B2	1/2007	Datta et al.	7,871,433	B2	1/2011	Lattouf
7,172,625	B2	2/2007	Shu et al.	7,883,475	B2	2/2011	Dupont et al.
7,175,660	B2	2/2007	Cartledge et al.	7,883,538	B2	2/2011	To et al.
7,186,262	B2	3/2007	Saadat	7,892,281	B2	2/2011	Seguin et al.
7,186,264	B2	3/2007	Liddicoat et al.	7,927,370	B2	4/2011	Webler et al.
7,189,199	B2	3/2007	McCarthy et al.	7,927,371	B2	4/2011	Navia et al.
7,192,443	B2	3/2007	Solem et al.	7,931,580	B2	4/2011	Gertner et al.
7,211,094	B2	5/2007	Gannoe et al.	7,942,927	B2	5/2011	Kaye et al.
7,220,277	B2	5/2007	Arru et al.	7,947,056	B2	5/2011	Griego et al.
7,226,467	B2	6/2007	Lucatero et al.	7,955,315	B2	6/2011	Feinberg et al.
7,226,477	B2	6/2007	Cox	7,955,377	B2	6/2011	Melsheimer
7,226,647	B2	6/2007	Kasperchik et al.	7,992,567	B2	8/2011	Hirotsuka et al.
7,229,452	B2	6/2007	Kayan	7,993,368	B2	8/2011	Gambale et al.
7,238,191	B2	7/2007	Bachmann	7,993,397	B2	8/2011	Lashinski et al.
7,247,134	B2	7/2007	Vidlund et al.	8,012,201	B2	9/2011	Lashinski et al.
7,288,097	B2	10/2007	Seguin	8,034,103	B2	10/2011	Burriesci et al.
7,294,148	B2	11/2007	McCarthy	8,052,592	B2	11/2011	Goldfarb et al.
7,311,728	B2	12/2007	Solem et al.	8,057,493	B2	11/2011	Goldfarb et al.
7,311,729	B2	12/2007	Mathis et al.	8,062,355	B2	11/2011	Figulla et al.
7,314,485	B2	1/2008	Mathis	8,070,804	B2	12/2011	Hyde et al.
7,316,710	B1	1/2008	Cheng et al.	8,070,805	B2	12/2011	Vidlund et al.
7,329,279	B2	2/2008	Haug et al.	8,075,616	B2	12/2011	Solem et al.
7,329,280	B2	2/2008	Bolling et al.	8,100,964	B2	1/2012	Spence
7,335,213	B1	2/2008	Hyde et al.	8,123,801	B2	2/2012	Milo
7,361,190	B2	4/2008	Shaoulian et al.	8,142,493	B2	3/2012	Spence et al.
7,364,588	B2	4/2008	Mathis et al.	8,142,495	B2	3/2012	Hasenkam et al.
7,377,941	B2	5/2008	Rhee et al.	8,142,496	B2	3/2012	Berrekouw
7,390,329	B2	6/2008	Westra et al.	8,147,542	B2	4/2012	Maisano et al.
7,404,824	B1	7/2008	Webler et al.	8,152,844	B2	4/2012	Rao et al.
7,431,692	B2	10/2008	Zollinger et al.	8,163,013	B2	4/2012	Machold et al.
7,442,207	B2	10/2008	Rafiee	8,172,871	B2	5/2012	Ken
7,452,376	B2	11/2008	Lim et al.	8,187,299	B2	5/2012	Goldfarb et al.
7,455,690	B2	11/2008	Cartledge et al.	8,187,324	B2	5/2012	Webler et al.
7,485,142	B2	2/2009	Milo	8,202,315	B2	6/2012	Hlavka et al.
7,485,143	B2	2/2009	Webler et al.	8,206,439	B2	6/2012	Gomez Duran
7,500,989	B2	3/2009	Solem et al.	8,216,302	B2	7/2012	Wilson et al.
7,507,252	B2	3/2009	Lashinski et al.	8,231,671	B2	7/2012	Kim
7,510,575	B2	3/2009	Spenser et al.	8,262,725	B2	9/2012	Subramanian
7,510,577	B2	3/2009	Moaddeb et al.	8,265,758	B2	9/2012	Policker et al.
7,527,647	B2	5/2009	Spence	8,277,502	B2	10/2012	Miller et al.
7,530,995	B2	5/2009	Quijano et al.	8,287,584	B2	10/2012	Salahieh et al.
7,549,983	B2	6/2009	Roue et al.	8,287,591	B2	10/2012	Keidar et al.
7,559,936	B2	7/2009	Levine	8,292,884	B2	10/2012	Levine et al.
				8,303,608	B2	11/2012	Goldfarb et al.
				8,323,334	B2	12/2012	Deem et al.
				8,328,868	B2	12/2012	Paul et al.
				8,333,777	B2	12/2012	Schaller et al.

(56)

## References Cited

## U.S. PATENT DOCUMENTS

8,343,173 B2	1/2013	Starksen et al.	9,011,520 B2	4/2015	Miller et al.
8,343,174 B2	1/2013	Goldfarb et al.	9,011,530 B2	4/2015	Reich et al.
8,343,213 B2	1/2013	Salahieh et al.	9,023,100 B2	5/2015	Quadri et al.
8,349,002 B2	1/2013	Milo	9,072,603 B2	7/2015	Tuval et al.
8,353,956 B2	1/2013	Miller et al.	9,107,749 B2	8/2015	Bobo et al.
8,357,195 B2	1/2013	Kuehn	9,119,719 B2	9/2015	Zipory et al.
8,382,829 B1	2/2013	Call et al.	9,125,632 B2	9/2015	Loumet et al.
8,388,680 B2	3/2013	Starksen et al.	9,125,742 B2	9/2015	Yoganathan et al.
8,393,517 B2	3/2013	Milo	9,138,316 B2	9/2015	Bielefeld
8,419,825 B2	4/2013	Burgler et al.	9,173,646 B2	11/2015	Fabro
8,430,926 B2	4/2013	Kirson	9,180,005 B1	11/2015	Lashinski et al.
8,449,573 B2	5/2013	Chu	9,180,007 B2	11/2015	Reich et al.
8,449,599 B2	5/2013	Chau et al.	9,192,472 B2	11/2015	Gross et al.
8,454,686 B2	6/2013	Alkhatib	9,198,756 B2	12/2015	Aklog et al.
8,460,370 B2	6/2013	Zakay	9,226,825 B2	1/2016	Starksen et al.
8,460,371 B2	6/2013	Hlavka et al.	9,265,608 B2	2/2016	Miller et al.
8,475,491 B2	7/2013	Milo	9,326,857 B2	5/2016	Cartledge et al.
8,475,525 B2	7/2013	Maisano et al.	9,414,921 B2	8/2016	Miller et al.
8,480,732 B2	7/2013	Subramanian	9,427,316 B2	8/2016	Schweich, Jr. et al.
8,518,107 B2	8/2013	Tsukashima et al.	9,474,606 B2	10/2016	Zipory et al.
8,523,940 B2	9/2013	Richardson et al.	9,526,613 B2	12/2016	Gross et al.
8,551,161 B2	10/2013	Dolan	9,561,104 B2	2/2017	Miller et al.
8,585,755 B2	11/2013	Chau et al.	9,693,865 B2	7/2017	Gilmore et al.
8,591,576 B2	11/2013	Hasenkam et al.	9,730,793 B2	8/2017	Reich et al.
8,608,797 B2	12/2013	Gross et al.	9,788,941 B2	10/2017	Hacohen
8,628,569 B2	1/2014	Benichou et al.	9,801,720 B2	10/2017	Gilmore et al.
8,628,571 B1	1/2014	Hacohen et al.	9,814,454 B2*	11/2017	Sugimoto ..... A61B 17/00234
8,641,727 B2	2/2014	Starksen et al.	9,907,547 B2	3/2018	Gilmore et al.
8,652,202 B2	2/2014	Alon et al.	10,368,852 B2	8/2019	Gerhardt et al.
8,652,203 B2	2/2014	Quadri et al.	2001/0005787 A1	6/2001	Oz et al.
8,679,174 B2	3/2014	Ottma et al.	2001/0021874 A1	9/2001	Carpentier et al.
8,685,086 B2	4/2014	Navia et al.	2001/0039436 A1	11/2001	Frazier et al.
8,728,097 B1	5/2014	Sugimoto et al.	2001/0049492 A1	12/2001	Frazier et al.
8,728,155 B2	5/2014	Montorfano et al.	2001/0051815 A1	12/2001	Esplin
8,734,467 B2	5/2014	Miller et al.	2002/0013571 A1	1/2002	Goldfarb et al.
8,734,699 B2	5/2014	Heideman et al.	2002/0016628 A1	2/2002	Langberg et al.
8,740,920 B2	6/2014	Goldfarb et al.	2002/0019649 A1	2/2002	Sikora et al.
8,747,463 B2	6/2014	Fogarty et al.	2002/0022862 A1	2/2002	Grafton et al.
8,778,021 B2	7/2014	Cartledge	2002/0026198 A1	2/2002	Ockuly et al.
8,784,481 B2	7/2014	Alkhatib et al.	2002/0026216 A1	2/2002	Grimes
8,790,367 B2	7/2014	Nguyen et al.	2002/0029080 A1	3/2002	Mortier et al.
8,790,394 B2	7/2014	Miller et al.	2002/0042621 A1	4/2002	Liddicoat et al.
8,795,298 B2	8/2014	Hernlund et al.	2002/0072758 A1	6/2002	Reo et al.
8,795,355 B2	8/2014	Alkhatib	2002/0082525 A1	6/2002	Oslund et al.
8,795,356 B2	8/2014	Quadri et al.	2002/0087048 A1	7/2002	Brock et al.
8,795,357 B2	8/2014	Yohanan et al.	2002/0087169 A1	7/2002	Brock et al.
8,808,366 B2	8/2014	Braido et al.	2002/0087173 A1	7/2002	Alferness et al.
8,808,368 B2	8/2014	Maisano et al.	2002/0087178 A1	7/2002	Nobles et al.
8,845,717 B2	9/2014	Khairkhahan et al.	2002/0095167 A1	7/2002	Liddicoat et al.
8,845,723 B2	9/2014	Spence et al.	2002/0100485 A1	8/2002	Stevens et al.
8,852,261 B2	10/2014	White	2002/0103532 A1	8/2002	Langberg et al.
8,852,272 B2	10/2014	Gross et al.	2002/0107531 A1	8/2002	Schreck et al.
8,858,623 B2	10/2014	Miller et al.	2002/0128708 A1	9/2002	Northrup, III et al.
8,864,822 B2	10/2014	Spence et al.	2002/0151916 A1	10/2002	Muramatsu et al.
8,870,948 B1	10/2014	Erzberger et al.	2002/0151970 A1	10/2002	Garrison et al.
8,870,949 B2	10/2014	Rowe	2002/0156526 A1	10/2002	Hlavka et al.
8,889,861 B2	11/2014	Skead et al.	2002/0165535 A1	11/2002	Lesh et al.
8,888,843 B2	11/2014	Khairkhahan et al.	2002/0169358 A1	11/2002	Mortier et al.
8,894,702 B2	11/2014	Quadri et al.	2002/0169359 A1	11/2002	McCarthy et al.
8,911,461 B2	12/2014	Traynor et al.	2002/0169502 A1	11/2002	Mathis
8,911,494 B2	12/2014	Hammer et al.	2002/0169504 A1	11/2002	Alferness et al.
8,926,696 B2	1/2015	Cabiri et al.	2002/0173841 A1	11/2002	Ortiz et al.
8,926,697 B2	1/2015	Gross et al.	2002/0177904 A1	11/2002	Huxel et al.
8,932,343 B2	1/2015	Alkhatib et al.	2002/0183766 A1	12/2002	Sequin
8,932,348 B2	1/2015	Solem et al.	2002/0183836 A1	12/2002	Liddicoat et al.
8,940,044 B2	1/2015	Hammer et al.	2002/0183837 A1	12/2002	Streeter et al.
8,945,211 B2	2/2015	Sugimoto	2002/0183838 A1	12/2002	Liddicoat et al.
8,951,285 B2	2/2015	Sugimoto et al.	2002/0183841 A1	12/2002	Cohn et al.
8,951,286 B2*	2/2015	Sugimoto ..... A61B 17/00234	2002/0188170 A1	12/2002	Santamore et al.
		606/232	2002/0188301 A1	12/2002	Dallara et al.
			2002/0188350 A1	12/2002	Arru et al.
			2002/0198586 A1	12/2002	Inoue
			2003/0018358 A1	1/2003	Saadat
			2003/0050693 A1	3/2003	Quijano et al.
			2003/0069593 A1	4/2003	Tremulis et al.
			2003/0069636 A1	4/2003	Solem et al.
			2003/0078465 A1	4/2003	Pai et al.
			2003/0078653 A1	4/2003	Vesely et al.
			2003/0078654 A1	4/2003	Taylor et al.
8,961,595 B2	2/2015	Alkhatib			
8,961,602 B2	2/2015	Kovach et al.			
8,979,922 B2	3/2015	Jayasinghe et al.			
8,992,604 B2	3/2015	Gross et al.			
9,005,273 B2	4/2015	Salahieh et al.			

(56)

## References Cited

## U.S. PATENT DOCUMENTS

2003/0078671	A1	4/2003	Lesniak et al.	2005/0049681	A1	3/2005	Greenhalgh et al.
2003/0083538	A1	5/2003	Adams et al.	2005/0049692	A1	3/2005	Numamoto et al.
2003/0105474	A1	6/2003	Bonutti	2005/0055038	A1	3/2005	Kelleher et al.
2003/0105519	A1	6/2003	Fasol et al.	2005/0055087	A1	3/2005	Starksen
2003/0105520	A1	6/2003	Alferness et al.	2005/0055089	A1	3/2005	Macoviak et al.
2003/0114901	A1	6/2003	Loeb et al.	2005/0060030	A1	3/2005	Lashinski et al.
2003/0120340	A1	6/2003	Liska et al.	2005/0065550	A1	3/2005	Starksen et al.
2003/0130730	A1	7/2003	Cohn et al.	2005/0065601	A1	3/2005	Lee et al.
2003/0144657	A1	7/2003	Bowe et al.	2005/0070999	A1	3/2005	Spence
2003/0144697	A1	7/2003	Mathis et al.	2005/0075723	A1	4/2005	Schroeder et al.
2003/0160721	A1	8/2003	Gilboa et al.	2005/0075727	A1	4/2005	Wheatley
2003/0171760	A1	9/2003	Gambale	2005/0090827	A1	4/2005	Gedebou
2003/0171776	A1	9/2003	Adams et al.	2005/0090834	A1	4/2005	Chiang et al.
2003/0171806	A1	9/2003	Mathis et al.	2005/0096740	A1	5/2005	Langberg et al.
2003/0199974	A1	10/2003	Lee et al.	2005/0107810	A1	5/2005	Morales et al.
2003/0204195	A1	10/2003	Keane et al.	2005/0107812	A1	5/2005	Starksen et al.
2003/0204205	A1	10/2003	Sauer et al.	2005/0107871	A1	5/2005	Realyvasquez et al.
2003/0208195	A1	11/2003	Thompson et al.	2005/0119523	A1	6/2005	Starksen et al.
2003/0212453	A1	11/2003	Mathis et al.	2005/0119734	A1	6/2005	Spence et al.
2003/0220685	A1	11/2003	Hlavka et al.	2005/0119735	A1	6/2005	Spence et al.
2003/0229350	A1	12/2003	Kay	2005/0125002	A1	6/2005	Baran et al.
2003/0229395	A1	12/2003	Cox	2005/0125011	A1	6/2005	Spence et al.
2003/0233142	A1	12/2003	Morales et al.	2005/0125031	A1	6/2005	Pupenhagen et al.
2004/0003819	A1	1/2004	St. Goar et al.	2005/0131438	A1	6/2005	Cohn
2004/0010287	A1	1/2004	Bonutti	2005/0131533	A1	6/2005	Alfieri et al.
2004/0019359	A1	1/2004	Worley et al.	2005/0137686	A1	6/2005	Salahieh et al.
2004/0019377	A1	1/2004	Taylor et al.	2005/0137688	A1	6/2005	Salahieh et al.
2004/0019378	A1	1/2004	Hlavka et al.	2005/0137695	A1	6/2005	Salahieh et al.
2004/0024414	A1	2/2004	Downing	2005/0137700	A1	6/2005	Spence et al.
2004/0024451	A1	2/2004	Johnson et al.	2005/0143811	A1	6/2005	Realyvasquez
2004/0030382	A1	2/2004	St. Goar et al.	2005/0148815	A1	7/2005	Mortier et al.
2004/0039442	A1	2/2004	St. Goar et al.	2005/0149014	A1	7/2005	Hauck et al.
2004/0044364	A1	3/2004	DeVries et al.	2005/0159728	A1	7/2005	Armour et al.
2004/0049211	A1	3/2004	Tremulis et al.	2005/0159810	A1	7/2005	Filsoufi
2004/0059413	A1	3/2004	Argento	2005/0171601	A1	8/2005	Cosgrove et al.
2004/0092962	A1	5/2004	Thornton et al.	2005/0177180	A1	8/2005	Kaganov et al.
2004/0093023	A1	5/2004	Allen et al.	2005/0177228	A1	8/2005	Solem et al.
2004/0097865	A1	5/2004	Anderson et al.	2005/0184122	A1	8/2005	Hlavka et al.
2004/0122456	A1	6/2004	Saadat et al.	2005/0187568	A1	8/2005	Klenk et al.
2004/0122514	A1	6/2004	Fogarty et al.	2005/0192596	A1	9/2005	Jugenheimer
2004/0127982	A1	7/2004	Machold et al.	2005/0197693	A1	9/2005	Pai et al.
2004/0127983	A1	7/2004	Mortier et al.	2005/0203549	A1	9/2005	Realyvasquez
2004/0133063	A1	7/2004	McCarthy et al.	2005/0203606	A1	9/2005	VanCamp
2004/0133274	A1	7/2004	Webler et al.	2005/0216039	A1	9/2005	Lederman
2004/0133374	A1	7/2004	Kattan	2005/0216079	A1	9/2005	MaCoviak
2004/0138744	A1	7/2004	Lashinski et al.	2005/0222665	A1	10/2005	Aranyi
2004/0138745	A1	7/2004	Macoviak et al.	2005/0234481	A1	10/2005	Waller
2004/0147958	A1	7/2004	Lam et al.	2005/0251157	A1	11/2005	Saadat et al.
2004/0148019	A1	7/2004	Vidlund et al.	2005/0251159	A1	11/2005	Ewers et al.
2004/0148020	A1	7/2004	Vidlund et al.	2005/0251202	A1	11/2005	Ewers et al.
2004/0148021	A1	7/2004	Cartledge et al.	2005/0251205	A1	11/2005	Ewers et al.
2004/0152947	A1	8/2004	Schroeder et al.	2005/0251206	A1	11/2005	Maahs et al.
2004/0162568	A1	8/2004	Saadat et al.	2005/0251207	A1	11/2005	Flores et al.
2004/0167539	A1	8/2004	Kuehn et al.	2005/0251208	A1	11/2005	Elmer et al.
2004/0167620	A1	8/2004	Ortiz et al.	2005/0251209	A1	11/2005	Saadat et al.
2004/0172046	A1	9/2004	Hlavka et al.	2005/0251210	A1	11/2005	Westra et al.
2004/0176788	A1	9/2004	Opolski	2005/0256532	A1	11/2005	Nayak et al.
2004/0181287	A1	9/2004	Gellman	2005/0267478	A1	12/2005	Corradi et al.
2004/0186486	A1	9/2004	Roue et al.	2005/0267533	A1	12/2005	Gertner
2004/0186566	A1	9/2004	Hindrichs et al.	2005/0267571	A1	12/2005	Spence et al.
2004/0193191	A1	9/2004	Starksen et al.	2005/0273138	A1	12/2005	To et al.
2004/0220473	A1	11/2004	Lualdi	2005/0283192	A1	12/2005	Torrie et al.
2004/0236419	A1	11/2004	Milo	2005/0288694	A1	12/2005	Solomon
2004/0243153	A1	12/2004	Liddicoat et al.	2005/0288778	A1	12/2005	Shaoulian et al.
2004/0243227	A1	12/2004	Starksen et al.	2006/0004410	A1	1/2006	Nobis et al.
2004/0260317	A1	12/2004	Bloom et al.	2006/0004442	A1	1/2006	Spenser et al.
2004/0260393	A1	12/2004	Rahdert et al.	2006/0004443	A1	1/2006	Liddicoat et al.
2004/0260394	A1	12/2004	Douk et al.	2006/0009784	A1	1/2006	Behl et al.
2004/0267358	A1	12/2004	Reitan	2006/0020326	A9	1/2006	Bolduc et al.
2005/0004668	A1	1/2005	Aklog et al.	2006/0020327	A1	1/2006	Lashinski et al.
2005/0010287	A1	1/2005	Macoviak et al.	2006/0020333	A1	1/2006	Lashinski et al.
2005/0010787	A1	1/2005	Tarbouriech	2006/0020336	A1	1/2006	Liddicoat
2005/0016560	A1	1/2005	Voughlohn	2006/0025787	A1	2/2006	Morales et al.
2005/0033446	A1	2/2005	Deem et al.	2006/0025858	A1	2/2006	Alameddine
2005/0049634	A1	3/2005	Chopra	2006/0030885	A1	2/2006	Hyde
				2006/0041319	A1	2/2006	Taylor et al.
				2006/0069429	A1	3/2006	Spence et al.
				2006/0074486	A1	4/2006	Liddicoat et al.
				2006/0085012	A1	4/2006	Dolan

(56)	<b>References Cited</b>						
	U.S. PATENT DOCUMENTS						
2006/0095009	A1	5/2006	Lampropoulos et al.	2008/0065011	A1	3/2008	Marchand et al.
2006/0106423	A1	5/2006	Weisel et al.	2008/0065204	A1	3/2008	Macoviak et al.
2006/0116757	A1	6/2006	Lashinski et al.	2008/0071366	A1	3/2008	Tuval et al.
2006/0122633	A1	6/2006	To et al.	2008/0086138	A1	4/2008	Stone et al.
2006/0129166	A1	6/2006	Lavelle	2008/0086203	A1	4/2008	Roberts
2006/0142756	A1	6/2006	Davies et al.	2008/0091169	A1	4/2008	Heideman et al.
2006/0149280	A1	7/2006	Harvie et al.	2008/0091257	A1	4/2008	Andreas et al.
2006/0149368	A1	7/2006	Spence	2008/0097523	A1	4/2008	Bolduc et al.
2006/0161040	A1	7/2006	McCarthy et al.	2008/0103572	A1	5/2008	Gerber
2006/0161265	A1	7/2006	Levine et al.	2008/0140116	A1	6/2008	Bonutti
2006/0178682	A1	8/2006	Boehlke	2008/0167713	A1	7/2008	Bolling
2006/0184240	A1	8/2006	Jimenez et al.	2008/0167714	A1	7/2008	St. Goar et al.
2006/0184242	A1	8/2006	Lichtenstein	2008/0195126	A1	8/2008	Solem
2006/0195134	A1	8/2006	Crittenden	2008/0195200	A1	8/2008	Vidlund et al.
2006/0206203	A1	9/2006	Yang et al.	2008/0208265	A1	8/2008	Frazier et al.
2006/0212045	A1	9/2006	Schilling et al.	2008/0221672	A1	9/2008	Lamphere et al.
2006/0241622	A1	10/2006	Zergiebel	2008/0228165	A1	9/2008	Spence et al.
2006/0241656	A1	10/2006	Starksen et al.	2008/0228198	A1	9/2008	Traynor et al.
2006/0241748	A1	10/2006	Lee et al.	2008/0228265	A1	9/2008	Spence et al.
2006/0247763	A1	11/2006	Slater	2008/0228266	A1	9/2008	McNamara et al.
2006/0259135	A1	11/2006	Navia et al.	2008/0228267	A1	9/2008	Spence et al.
2006/0271175	A1	11/2006	Woolfson et al.	2008/0262480	A1	10/2008	Stahler et al.
2006/0282161	A1	12/2006	Huynh et al.	2008/0262609	A1	10/2008	Gross et al.
2006/0287661	A1	12/2006	Bolduc et al.	2008/0275300	A1	11/2008	Rothe et al.
2006/0287716	A1	12/2006	Banbury et al.	2008/0275469	A1	11/2008	Fanton et al.
2007/0001627	A1	1/2007	Lin et al.	2008/0275503	A1	11/2008	Spence et al.
2007/0010857	A1	1/2007	Sugimoto et al.	2008/0275551	A1	11/2008	Alfieri
2007/0016287	A1	1/2007	Cartledge et al.	2008/0281353	A1	11/2008	Aranyi et al.
2007/0016288	A1	1/2007	Gurskis et al.	2008/0281411	A1	11/2008	Berrekouw
2007/0021781	A1	1/2007	Jervis et al.	2008/0288044	A1	11/2008	Osborne
2007/0027533	A1	2/2007	Douk	2008/0288062	A1	11/2008	Andrieu et al.
2007/0027536	A1	2/2007	Mihaljevic et al.	2008/0300537	A1	12/2008	Bowman
2007/0038221	A1	2/2007	Fine	2008/0300629	A1	12/2008	Surti
2007/0038293	A1	2/2007	St.Goar et al.	2009/0018655	A1	1/2009	Brunelle et al.
2007/0038296	A1	2/2007	Navia et al.	2009/0028670	A1	1/2009	Garcia et al.
2007/0039425	A1	2/2007	Wang	2009/0043381	A1	2/2009	Macoviak et al.
2007/0049942	A1	3/2007	Hindrichs et al.	2009/0054969	A1	2/2009	Salahieh et al.
2007/0049970	A1	3/2007	Belef et al.	2009/0062866	A1	3/2009	Jackson
2007/0051377	A1	3/2007	Douk et al.	2009/0076586	A1	3/2009	Hauser et al.
2007/0055206	A1	3/2007	To et al.	2009/0076600	A1	3/2009	Quinn
2007/0055303	A1	3/2007	Vidlund et al.	2009/0088837	A1	4/2009	Gillinov et al.
2007/0061010	A1	3/2007	Hauser et al.	2009/0093877	A1	4/2009	Keidar et al.
2007/0066863	A1	3/2007	Rafiee et al.	2009/0099650	A1	4/2009	Bolduc et al.
2007/0078297	A1	4/2007	Rafiee et al.	2009/0105816	A1	4/2009	Olsen et al.
2007/0080188	A1	4/2007	Spence et al.	2009/0125102	A1	5/2009	Cartledge et al.
2007/0083168	A1	4/2007	Whiting et al.	2009/0171439	A1	7/2009	Nissl
2007/0100427	A1	5/2007	Perouse	2009/0177266	A1	7/2009	Powell et al.
2007/0106310	A1	5/2007	Goldin et al.	2009/0177274	A1	7/2009	Scorsin et al.
2007/0106328	A1	5/2007	Wardle et al.	2009/0248148	A1	10/2009	Shaolian et al.
2007/0112359	A1	5/2007	Kimura et al.	2009/0254103	A1	10/2009	Deutsch
2007/0112422	A1	5/2007	Dehdashtian	2009/0264994	A1	10/2009	Saadat
2007/0112424	A1	5/2007	Spence et al.	2009/0287231	A1	11/2009	Brooks et al.
2007/0118151	A1	5/2007	Davidson	2009/0287304	A1	11/2009	Dahlgren et al.
2007/0118154	A1	5/2007	Crabtree	2009/0299409	A1	12/2009	Coe et al.
2007/0118213	A1	5/2007	Loulmet	2009/0326648	A1	12/2009	Machold et al.
2007/0118215	A1	5/2007	Moaddeb	2010/0001038	A1	1/2010	Levin et al.
2007/0142907	A1	6/2007	Moaddeb et al.	2010/0010538	A1	1/2010	Juravic et al.
2007/0162111	A1	7/2007	Fukamachi et al.	2010/0023118	A1	1/2010	Medlock et al.
2007/0198082	A1	8/2007	Kapadia et al.	2010/0030014	A1	2/2010	Ferrazzi
2007/0219558	A1	9/2007	Deutsch	2010/0030328	A1	2/2010	Seguin et al.
2007/0239208	A1	10/2007	Crawford	2010/0042147	A1	2/2010	Janovsky et al.
2007/0255397	A1	11/2007	Ryan et al.	2010/0063542	A1	3/2010	van der Burg et al.
2007/0255400	A1	11/2007	Parravicini et al.	2010/0063550	A1	3/2010	Felix et al.
2007/0270755	A1	11/2007	Von Oepen et al.	2010/0076499	A1	3/2010	McNamara et al.
2007/0276437	A1	11/2007	Call et al.	2010/0094248	A1	4/2010	Nguyen et al.
2007/0282375	A1	12/2007	Hindrichs et al.	2010/0114180	A1	5/2010	Rock et al.
2007/0282429	A1	12/2007	Hauser et al.	2010/0121349	A1	5/2010	Meier et al.
2007/0295172	A1	12/2007	Swartz	2010/0121435	A1	5/2010	Subramanian et al.
2008/0004697	A1	1/2008	Lichtenstein et al.	2010/0121437	A1	5/2010	Subramanian et al.
2008/0027483	A1	1/2008	Cartledge et al.	2010/0130992	A1	5/2010	Machold et al.
2008/0027555	A1	1/2008	Hawkins	2010/0152845	A1	6/2010	Bloom et al.
2008/0035160	A1	2/2008	Woodson et al.	2010/0161043	A1	6/2010	Maisano et al.
2008/0039935	A1	2/2008	Buch et al.	2010/0168845	A1	7/2010	Wright
2008/0051703	A1	2/2008	Thornton et al.	2010/0174358	A1	7/2010	Rabkin et al.
2008/0058595	A1	3/2008	Snoke et al.	2010/0179574	A1	7/2010	Longoria et al.
				2010/0217184	A1	8/2010	Koblish et al.
				2010/0217382	A1	8/2010	Chau et al.
				2010/0234935	A1	9/2010	Bashiri et al.
				2010/0249908	A1	9/2010	Chau et al.

(56)

References Cited

U.S. PATENT DOCUMENTS

2010/0249915 A1 9/2010 Zhang  
 2010/0249920 A1 9/2010 Bolling et al.  
 2010/0262232 A1 10/2010 Annest  
 2010/0262233 A1 10/2010 He  
 2010/0286628 A1 11/2010 Gross  
 2010/0305475 A1 12/2010 Hinchliffe et al.  
 2010/0324598 A1 12/2010 Anderson  
 2011/0004210 A1 1/2011 Johnson et al.  
 2011/0004298 A1 1/2011 Lee et al.  
 2011/0009956 A1 1/2011 Cartledge et al.  
 2011/0011917 A1 1/2011 Loulmet  
 2011/0026208 A1 2/2011 Utsuro et al.  
 2011/0029066 A1 2/2011 Gilad et al.  
 2011/0035000 A1 2/2011 Nieminen et al.  
 2011/0066231 A1 3/2011 Cartledge et al.  
 2011/0067770 A1 3/2011 Pederson et al.  
 2011/0071626 A1 3/2011 Wright et al.  
 2011/0082538 A1 4/2011 Dahlgren et al.  
 2011/0087146 A1 4/2011 Ryan et al.  
 2011/0093002 A1 4/2011 Rucker et al.  
 2011/0118832 A1 5/2011 Punjabi  
 2011/0137410 A1 6/2011 Hacoheh  
 2011/0144703 A1 6/2011 Krause et al.  
 2011/0202130 A1 8/2011 Cartledge et al.  
 2011/0208283 A1 8/2011 Rust  
 2011/0230941 A1 9/2011 Markus  
 2011/0230961 A1 9/2011 Langer et al.  
 2011/0238088 A1 9/2011 Bolduc et al.  
 2011/0257433 A1 10/2011 Walker  
 2011/0257633 A1 10/2011 Cartledge et al.  
 2011/0264208 A1 10/2011 Duffy et al.  
 2011/0276062 A1 11/2011 Bolduc  
 2011/0288435 A1 11/2011 Christy et al.  
 2011/0301498 A1 12/2011 Maenhout et al.  
 2012/0078355 A1 3/2012 Zipory et al.  
 2012/0078359 A1 3/2012 Li et al.  
 2012/0089022 A1 4/2012 House et al.  
 2012/0095552 A1 4/2012 Spence et al.  
 2012/0109155 A1 5/2012 Robinson et al.  
 2012/0150290 A1 6/2012 Gabbay  
 2012/0158021 A1 6/2012 Morrill  
 2012/0179086 A1 7/2012 Shank et al.  
 2012/0191182 A1 7/2012 Hauser et al.  
 2012/0226349 A1 9/2012 Tuval et al.  
 2012/0239142 A1 9/2012 Liu et al.  
 2012/0245604 A1 9/2012 Tegzes  
 2012/0271198 A1 10/2012 Whittaker et al.  
 2012/0296349 A1 11/2012 Smith et al.  
 2012/0296417 A1 11/2012 Hill et al.  
 2012/0310330 A1 12/2012 Buchbinder et al.  
 2012/0323313 A1 12/2012 Seguin  
 2013/0030522 A1 1/2013 Rowe et al.  
 2013/0046373 A1 2/2013 Cartledge et al.  
 2013/0079873 A1 3/2013 Migliazza et al.  
 2013/0085529 A1 4/2013 Housman  
 2013/0090724 A1 4/2013 Subramanian et al.  
 2013/0096673 A1 4/2013 Hill et al.  
 2013/0116776 A1 5/2013 Gross et al.  
 2013/0123910 A1 5/2013 Cartledge et al.  
 2013/0131791 A1 5/2013 Hlavka et al.  
 2013/0166017 A1 6/2013 Cartledge et al.  
 2013/0190863 A1 7/2013 Call et al.  
 2013/0204361 A1 8/2013 Adams et al.  
 2013/0226289 A1 8/2013 Shaolian et al.  
 2013/0226290 A1 8/2013 Yellin et al.  
 2013/0268069 A1 10/2013 Zakai et al.  
 2013/0289718 A1 10/2013 Tsukashima et al.  
 2013/0297013 A1 11/2013 Kliema et al.  
 2013/0304093 A1 11/2013 Serina et al.  
 2014/0081394 A1 3/2014 Keranen et al.  
 2014/0088368 A1 3/2014 Park  
 2014/0094826 A1 4/2014 Sutherland et al.  
 2014/0094903 A1 4/2014 Miller et al.  
 2014/0094906 A1 4/2014 Spence et al.  
 2014/0114390 A1 4/2014 Tobis et al.

2014/0135799 A1 5/2014 Henderson  
 2014/0142619 A1 5/2014 Serina et al.  
 2014/0142695 A1 5/2014 Gross et al.  
 2014/0148849 A1 5/2014 Serina et al.  
 2014/0155783 A1 6/2014 Starksen et al.  
 2014/0163670 A1 6/2014 Alon et al.  
 2014/0163690 A1 6/2014 White  
 2014/0188108 A1 7/2014 Goodine et al.  
 2014/0188140 A1 7/2014 Meier et al.  
 2014/0188215 A1 7/2014 Hlavka et al.  
 2014/0194976 A1 7/2014 Starksen et al.  
 2014/0207231 A1 7/2014 Hacoheh et al.  
 2014/0243859 A1 8/2014 Robinson  
 2014/0243894 A1 8/2014 Groothuis et al.  
 2014/0243963 A1 8/2014 Sheps et al.  
 2014/0275757 A1 9/2014 Goodwin et al.  
 2014/0276648 A1 9/2014 Hammer et al.  
 2014/0296962 A1 10/2014 Cartledge et al.  
 2014/0303649 A1 10/2014 Nguyen et al.  
 2014/0303720 A1 10/2014 Sugimoto et al.  
 2014/0309661 A1 10/2014 Sheps et al.  
 2014/0309730 A1 10/2014 Alon et al.  
 2014/0343668 A1 11/2014 Zipory et al.  
 2014/0350660 A1 11/2014 Cocks et al.  
 2014/0379006 A1 12/2014 Sutherland et al.  
 2015/0018940 A1 1/2015 Quill et al.  
 2015/0051697 A1 2/2015 Spence et al.  
 2015/0081014 A1 3/2015 Gross et al.  
 2015/0112432 A1 4/2015 Reich et al.  
 2015/0127097 A1 5/2015 Neumann et al.  
 2015/0182336 A1 7/2015 Zipory et al.  
 2015/0272586 A1 10/2015 Herman et al.  
 2015/0272734 A1 10/2015 Sheps et al.  
 2015/0282931 A1 10/2015 Brunnett et al.  
 2015/0351910 A1 12/2015 Gilmore et al.  
 2016/0008132 A1 1/2016 Cabiri et al.  
 2016/0058557 A1 3/2016 Reich et al.  
 2016/0113767 A1 4/2016 Miller et al.  
 2016/0120645 A1 5/2016 Alon  
 2016/0158008 A1 6/2016 Miller et al.  
 2016/0242762 A1 8/2016 Gilmore et al.  
 2016/0262755 A1 9/2016 Zipory et al.  
 2016/0302917 A1 10/2016 Schewel  
 2016/0317302 A1 11/2016 Madjarov et al.  
 2016/0361058 A1 12/2016 Bolduc et al.  
 2016/0361168 A1 12/2016 Gross et al.  
 2016/0361169 A1 12/2016 Gross et al.  
 2017/0000609 A1 1/2017 Gross et al.  
 2017/0224489 A1 8/2017 Starksen et al.  
 2017/0245993 A1 8/2017 Gross et al.  
 2018/0049875 A1 2/2018 Iflah et al.  
 2018/0318080 A1 11/2018 Quill et al.  
 2019/0038411 A1 2/2019 Alon

FOREIGN PATENT DOCUMENTS

EP 2181670 5/2010  
 EP 3531975 A1 9/2019  
 WO 9205093 A1 4/1992  
 WO WO 9604852 2/1996  
 WO 9846149 A1 10/1998  
 WO WO 9900059 1/1999  
 WO WO 0003759 1/2000  
 WO WO 0044311 8/2000  
 WO WO 0060995 10/2000  
 WO WO 0067640 11/2000  
 WO WO 0200099 1/2002  
 WO WO 02051329 7/2002  
 WO WO 02096275 12/2002  
 WO WO 03001893 1/2003  
 WO WO 03007796 1/2003  
 WO 02085250 A3 2/2003  
 WO 03047467 A1 6/2003  
 WO WO 03053289 7/2003  
 WO WO 03/077772 9/2003  
 WO WO 2004/037317 5/2004  
 WO WO 2004045378 6/2004  
 WO WO 2004/112658 12/2004  
 WO WO 2005011463 2/2005



(56)

**References Cited**

## FOREIGN PATENT DOCUMENTS

WO	WO 2005013832	2/2005
WO	WO 2005025644	3/2005
WO	WO 200558239	6/2005
WO	WO 2006/039296	4/2006
WO	WO 06064490	6/2006
WO	WO 2006105008	10/2006
WO	WO 07005394	1/2007
WO	WO 200891391	7/2008
WO	2010000454 A1	1/2010
WO	2012176195 A3	3/2013
WO	2014064964 A1	5/2014

## OTHER PUBLICATIONS

F. Maisano et al., The Double-Orifice Technique as a Standardized Approach to Treat Mitral Regurgitation Due to Severe Myxomatous Disease: Surgical Technique, *European Journal of Cardio-thoracic Surgery*, 1998.

Douglas P. Zipes, MD et al., Ablation of Free Wall Accessory Pathways, *Catheter Ablation of Arrhythmias*, Chapter 8, 7 pgs., 1994.

David L.S. Morales et al., Development of an Off Bypass Mitral Valve Repair, Department of Surgery, Columbia University, College of Physicians and Surgeons, New York, NY. Apr. 13, 1999.

Heart Surgery Forum, Aug. 8, 2000. p. 1. Tables 1-2. Web. [http://www.hsforum.com/vol2/issue2/1999-4963\\_tables.html](http://www.hsforum.com/vol2/issue2/1999-4963_tables.html).

Heart Surgery Forum, Aug. 8, 2000. pp. 1-4. Figures 1-8. Web. <http://www.hsforum.com/vol2/issue2/1999-4963figures.html>.

"Heart Valves: The Duran Flexible Annuloplasty Band—For Surgeons "Partial" to Flexibility." Medtronic. Feb. 23, 2001. Web. [http://medtronic.com/cardiac/heartvalves/duran\\_band/](http://medtronic.com/cardiac/heartvalves/duran_band/).

Zsolt L. Nagy et al., Mitral Annuloplasty With a Suture Technique, *European Journal of Cardio-thoracic Surgery* 18. Aug. 15, 2000, 1 pg.

Agarwal et al. International Cardiology Perspective Functional Tricuspid Regurgitation, *Circ Cardiovasc Interv* 2009;2;565-573 (2009).

Ahmadi, A., G. Spillner, and Th Johannesson, "Hemodynamic changes following experimental production and correction of acute mitral regurgitation with an adjustable ring prosthesis." *The Thoracic and cardiovascular surgeon* 36.06 (1988): 313-319.

Ahmadi, All et al. "Percutaneously adjustable pulmonary artery band." *The Annals of thoracic surgery* 60 (1995): S520-S522.

Alfieri et al. "Novel Suture Device for Beating-Heart Mitral Leaflet Approximation", *Ann Thorac Surg*. 2002, 74:1488-1493.

Alfieri et al., "An effective technique to correct anterior mitral leaflet prolapse," *J Card* 14(6):468-470 (1999).

Alfieri et al., "The double orifice technique in mitral valve repair: a simple solution for complex problems," *Journal of Thoracic Cardiovascular Surgery* 122:674-681 (2001).

Alfieri, "The edge-to-edge repair of the mitral valve," [Abstract] 6th Annual NewEra Cardiac Care: Innovation & Technology, Heart Surgery Forum pp. 103. (2000).

Amplatzer Cardiac Plug brochure (English pages), AGA Medical Corporation (Plymouth, MN) (copyright 2008-2010, downloaded Jan. 11, 2011).

AMPLATZER® Cribriform Occluder. A patient guide to Percutaneous, Transcatheter, Atrial Septal Defect Closer, AGA Medical Corporation, Apr. 2008.

AMPLATZER® Septal Occluder. A patient guide to the Non-Surgical Closer of the Atrial Septal Defect Using the AMPLATZER Septal Occluder System, AGA Medical Corporation, Apr. 2008.

Assad, Renato S. "Adjustable Pulmonary Artery Banding." (2014). Brennan, Jennifer, 510(k) Summary of safety and effectiveness, Jan. 2008.

Daebritz, S. et al. "Experience with an adjustable pulmonary artery banding device in two cases: initial success-midterm failure." *The Thoracic and cardiovascular surgeon* 47.01 (1999): 51-52.

Dang NC et al. "Simplified Placement of Multiple Artificial Mitral Valve Chords," *The Heart Surgery Forum* #2005-1005, 8 (3) (2005). Dictionary.com definition of "lock", Jul. 29, 2013.

Dieter RS, "Percutaneous valve repair: Update on mitral regurgitation and endovascular approaches to the mitral valve," *Applications in Imaging, Cardiac interventions*, Supported by an educational grant from Amersham Health pp. 11-14 (2003).

Elliott, Daniel S., Gerald W. Timm, and David M. Barrett. "An implantable mechanical urinary sphincter: a new nonhydraulic design concept." *Urology* 52.6 (1998): 1151-1154.

Langer et al. Ring plus String: Papillary muscle repositioning as an adjunctive repair technique for ischemic mitral regurgitation, *The Journal of Thoracic Cardiovascular surgery* vol. 133 No. 1, Jan. 2007.

Langer et al. Ring+String, Successful Repair technique for ischemic mitral regurgitation with severe leaflet tethering, The Department of Thoracic Cardiovascular surgery, Hamburg, Germany, Nov. 2008. Maisano, "The double-orifice technique as a standardized approach to treat mitral," *European Journal of Cardio-thoracic Surgery* 17 (2000) 201-205.

O'Reilly S et al., "Heart valve surgery pushes the envelope," *Medtech Insight* 8(3): 73, 99-108 (2006).

Odell JA et al., "Early Results of a Simplified Method of Mitral Valve Annuloplasty," *Circulation* 92:150-154 (1995).

Park, Sang C. et al. "A percutaneously adjustable device for banding of the pulmonary trunk." *International journal of cardiology* 9.4 (1985): 477-484.

Swain CP et al., "An endoscopically deliverable tissue-transfixing device for securing biosensors in the gastrointestinal tract," *Gastrointestinal Endoscopy* 40(6): 730-734 (1994).

Swenson, O. An experimental implantable urinary sphincter. *Invest Urol. Sep.* 1976;14(2):100-3.

Swenson, O. and Malinin, T.I., 1978. An improved mechanical device for control of urinary incontinence. *Investigative urology*, 15(5), pp. 389-391.

Swenson, Orvar. "Internal device for control of urinary incontinence." *Journal of pediatric surgery* 7.5 (1972): 542-545.

Tajik, Abdul, "Two dimensional real-time ultrasonic imaging of the heart and great vessels", *Mayo Clin Proc.* vol. 53:271-303, 1978.

\* cited by examiner

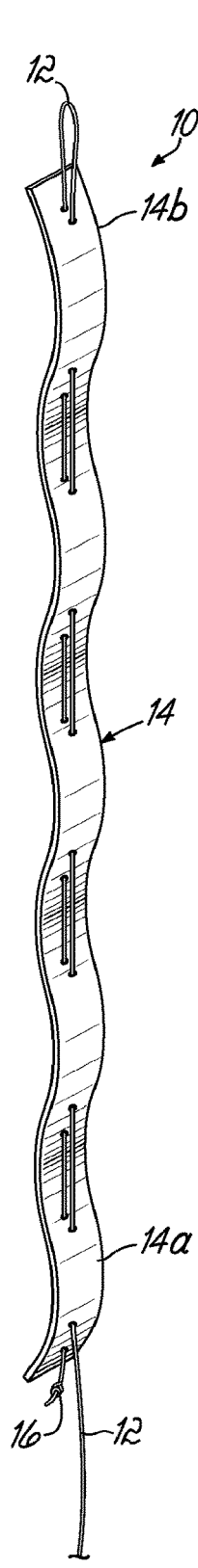

FIG. 1

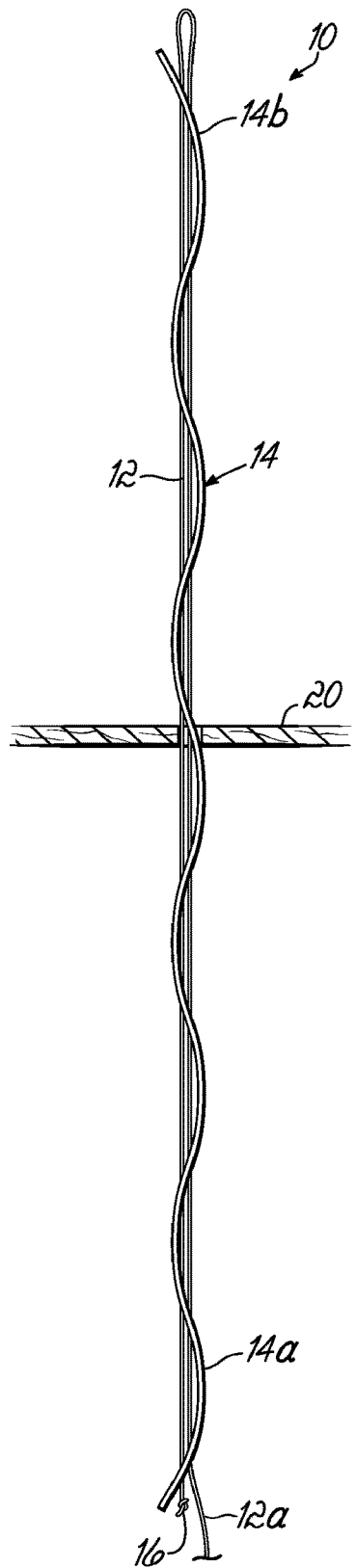

FIG. 2A

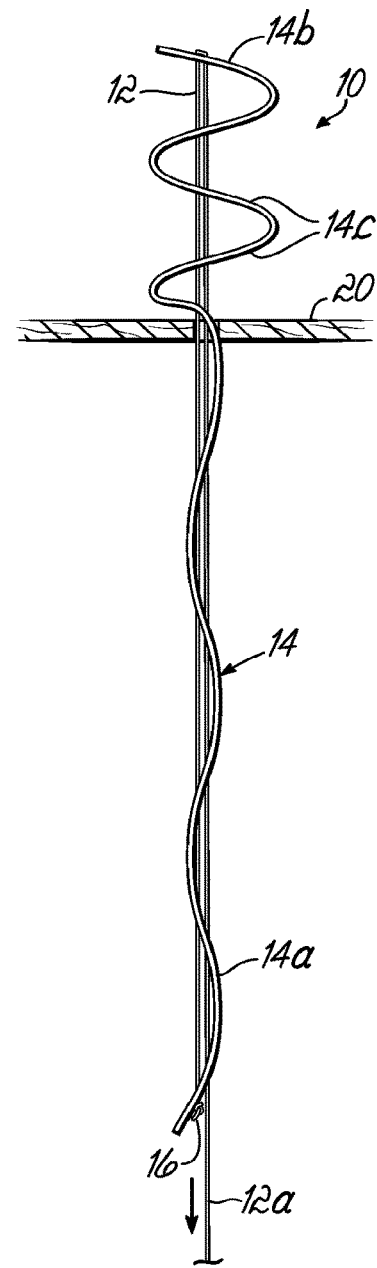

FIG. 2B

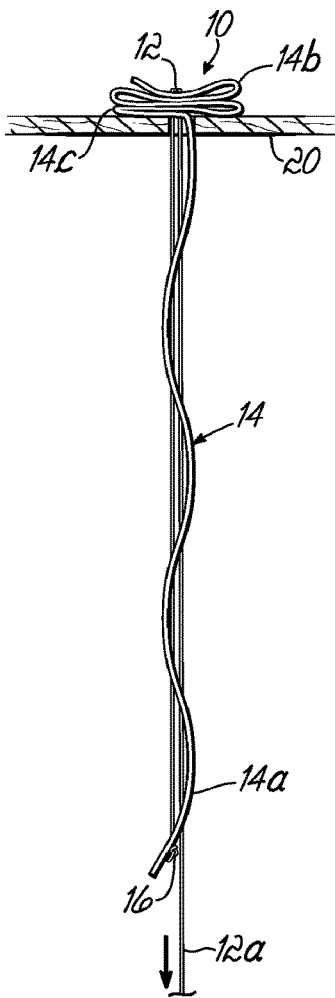

FIG. 2C

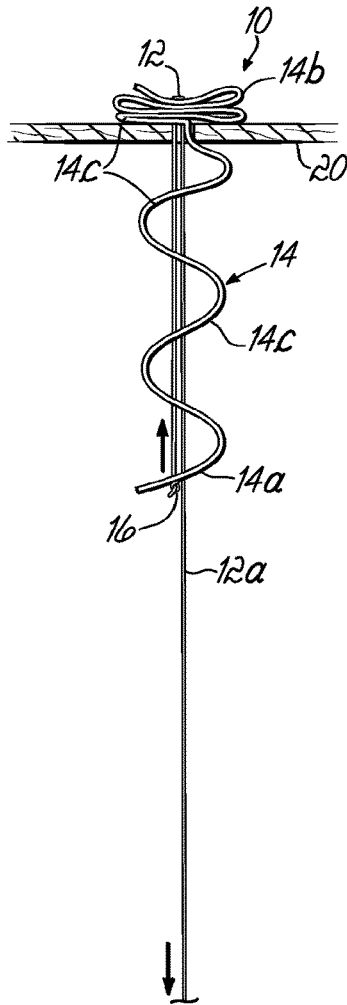

FIG. 2D

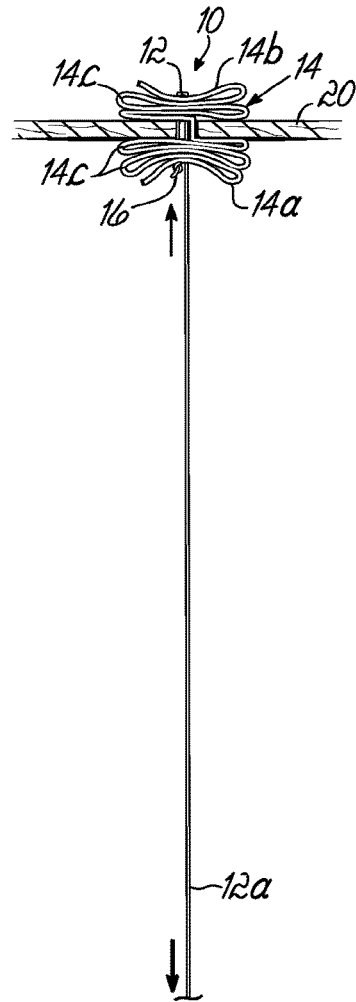

FIG. 2E

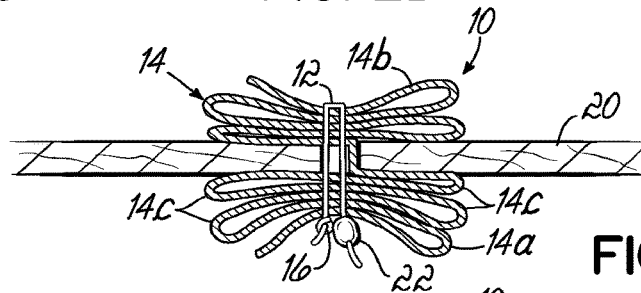

FIG. 2F

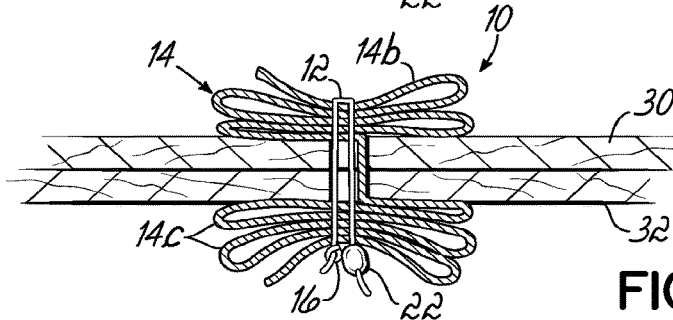

FIG. 3



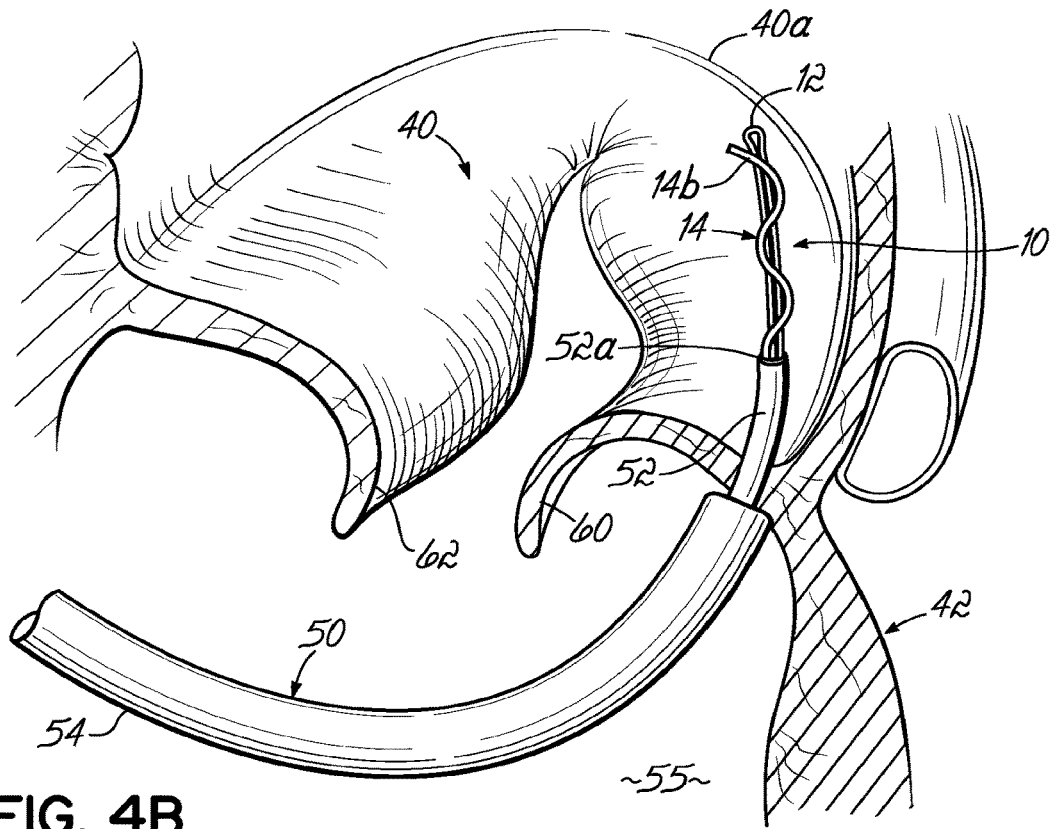

FIG. 4B

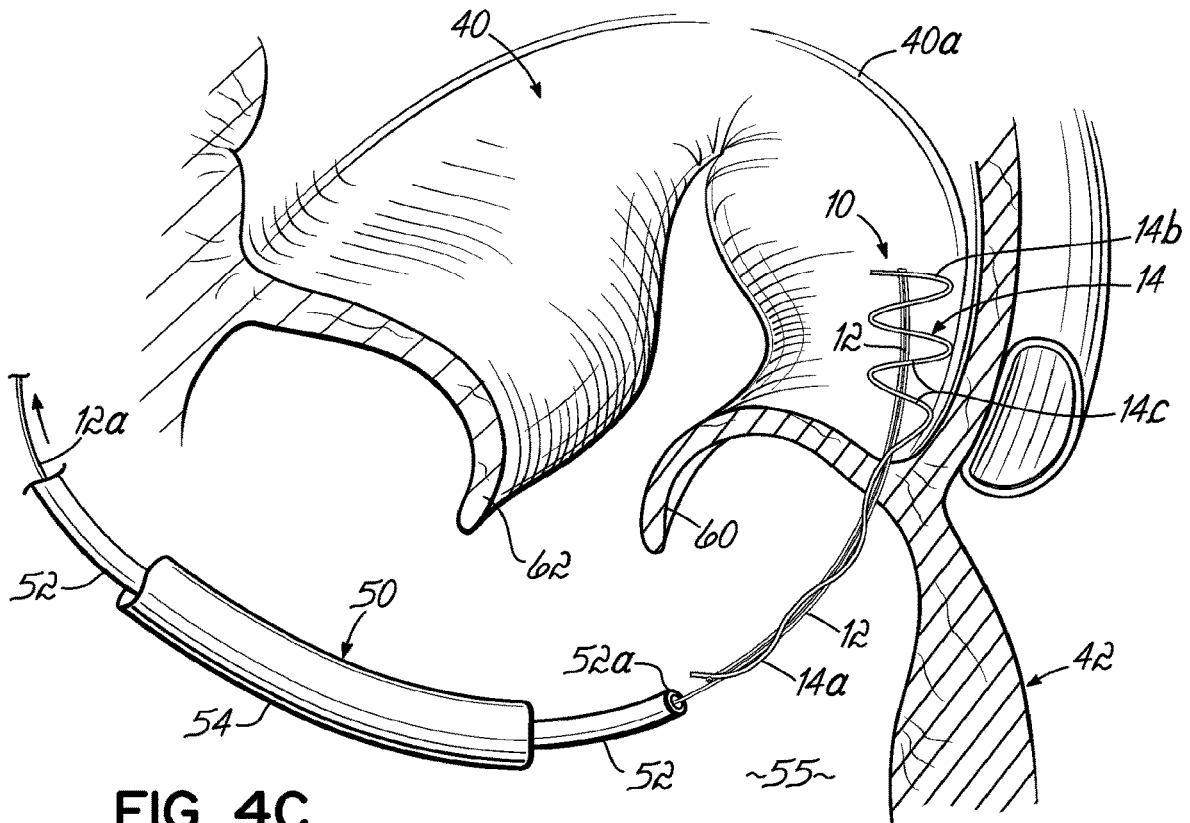

FIG. 4C

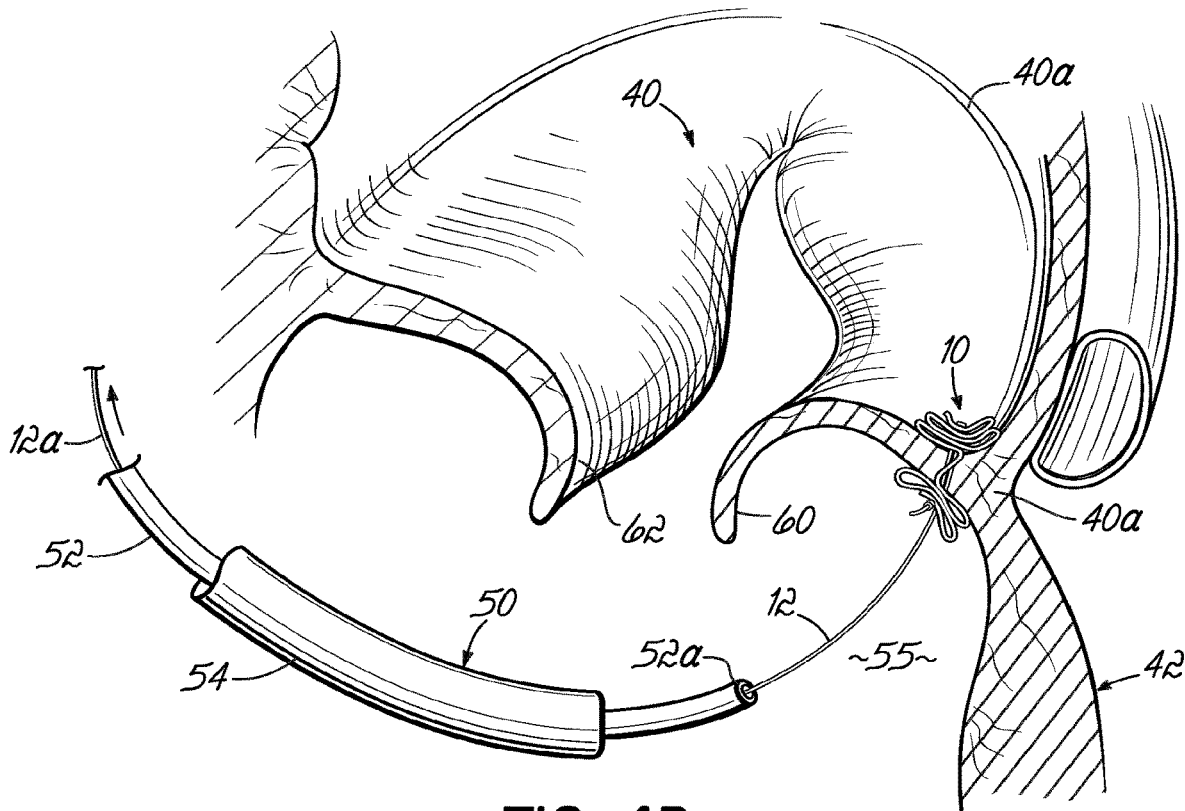

FIG. 4D

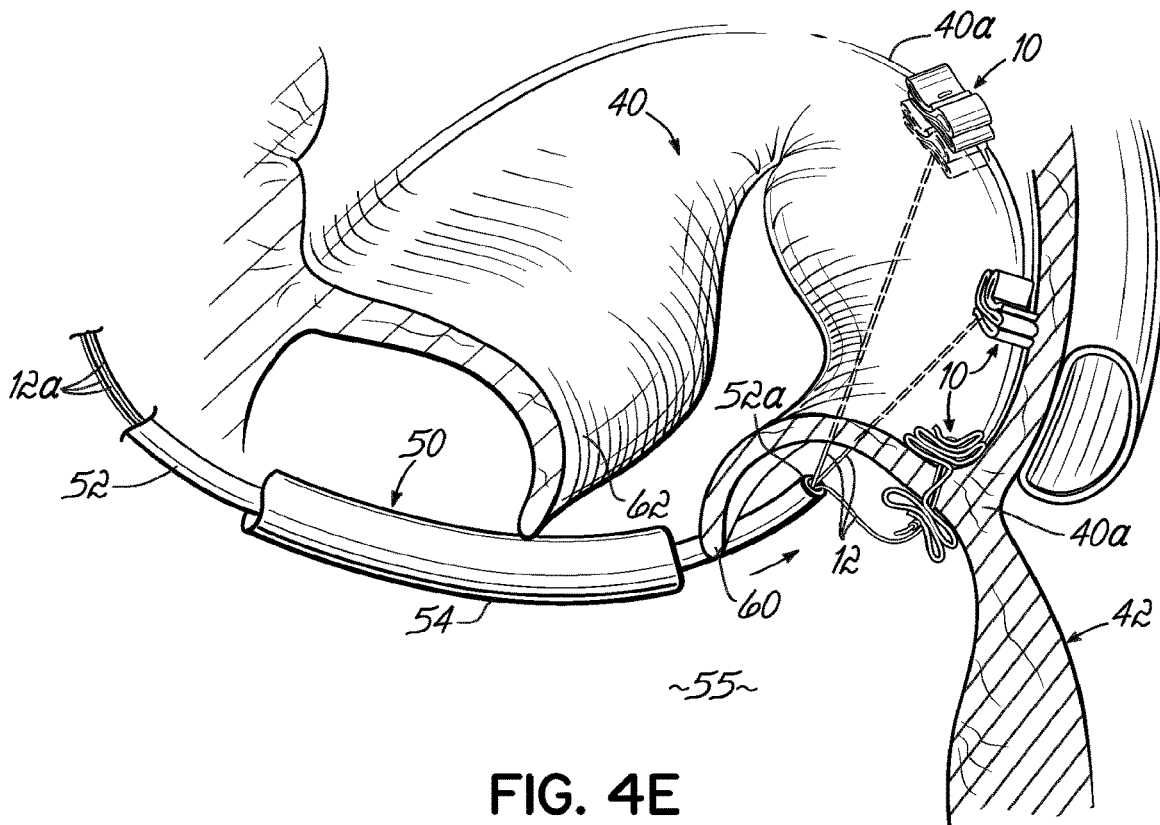

FIG. 4E

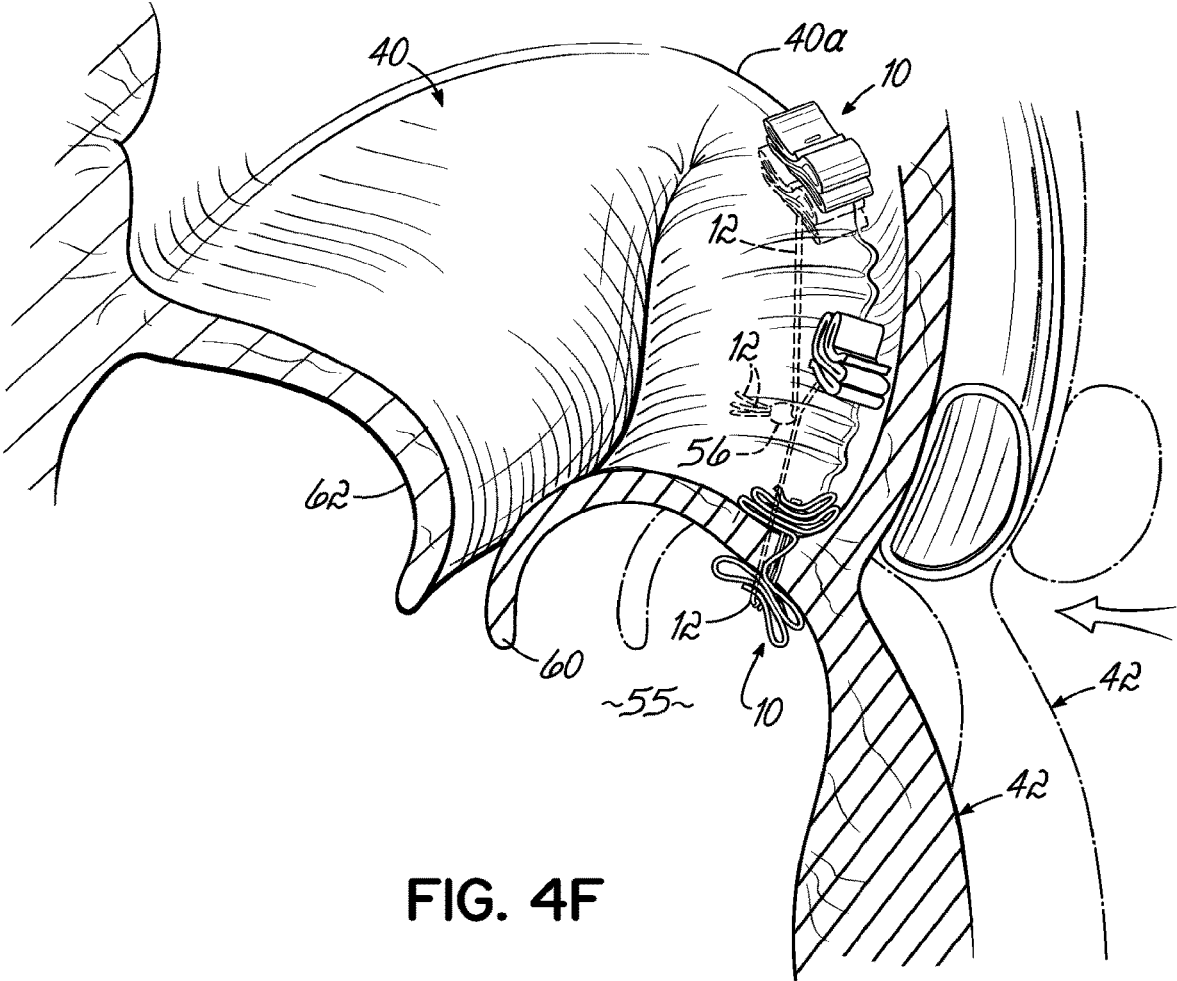

FIG. 4F

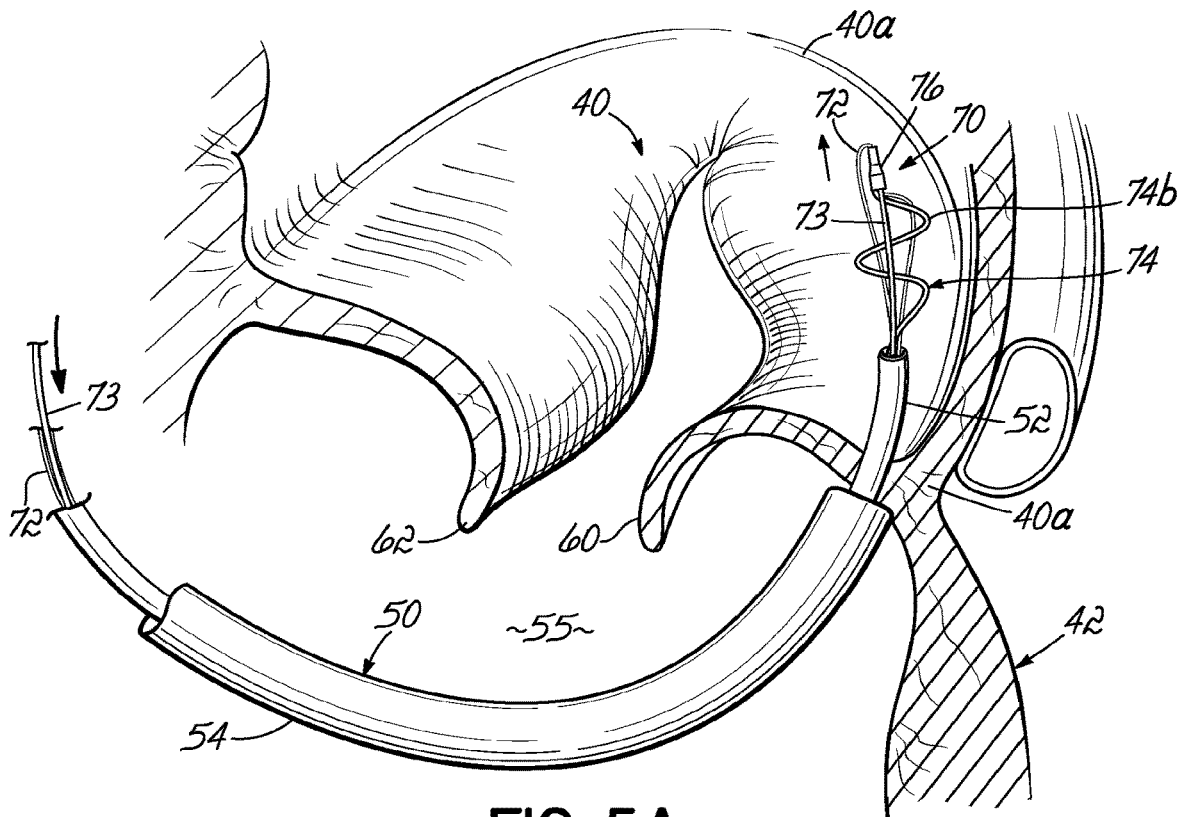

FIG. 5A

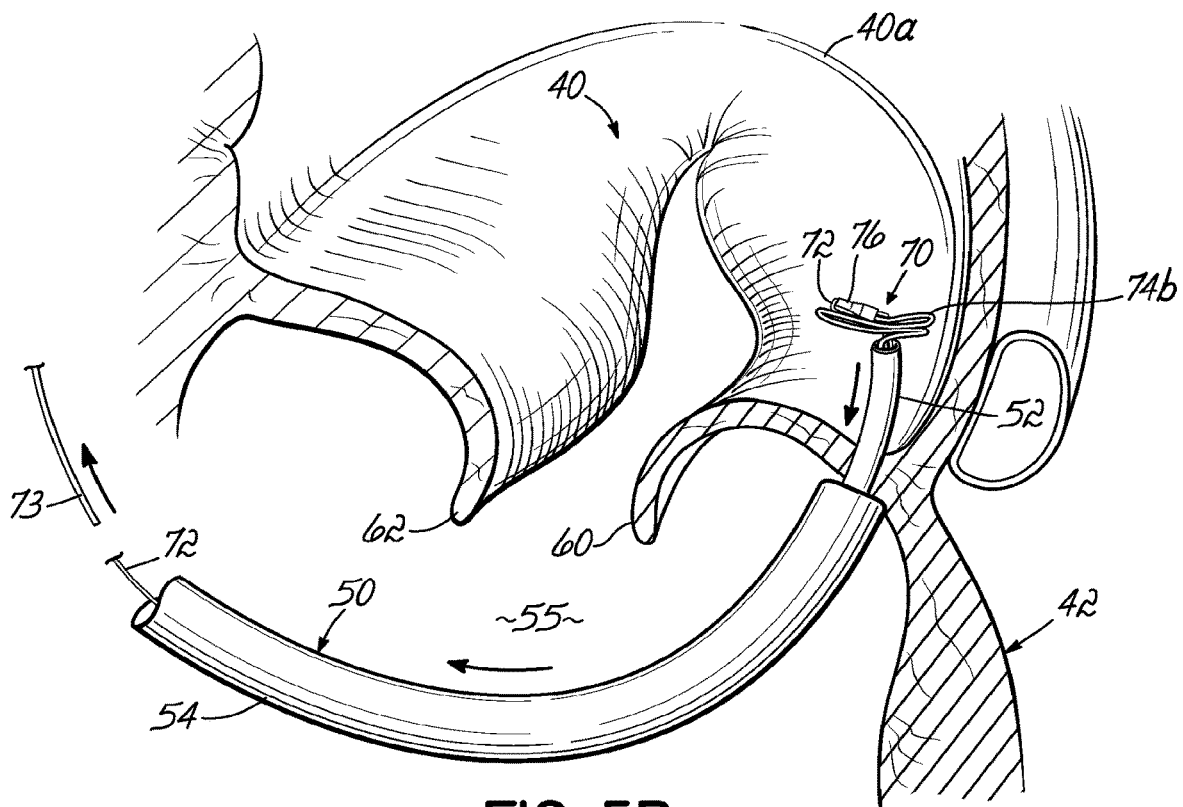

FIG. 5B



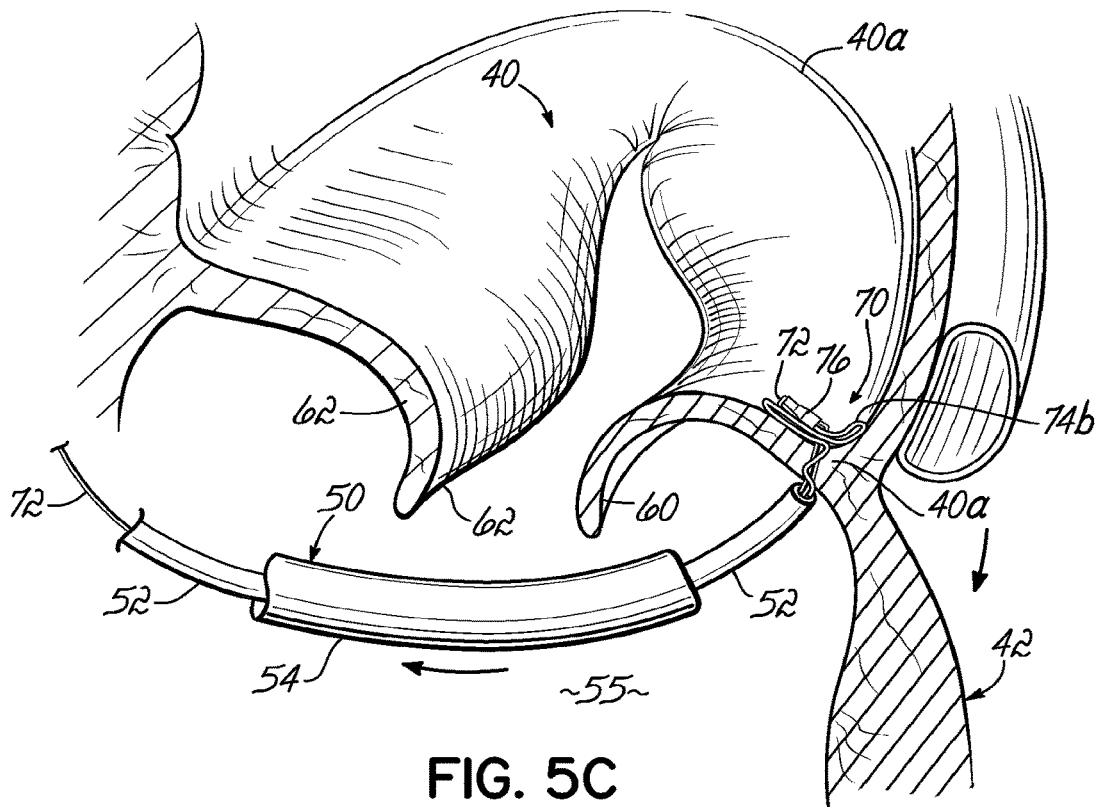

FIG. 5C

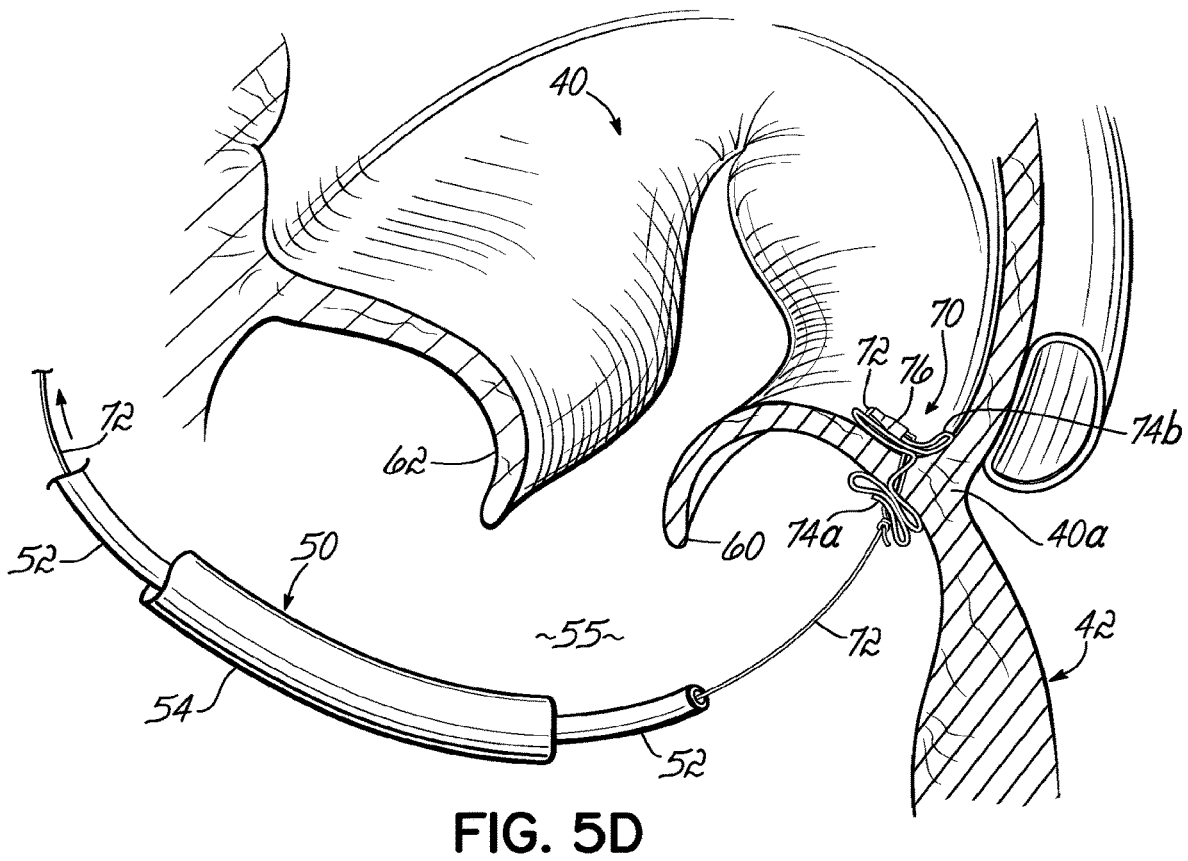

FIG. 5D

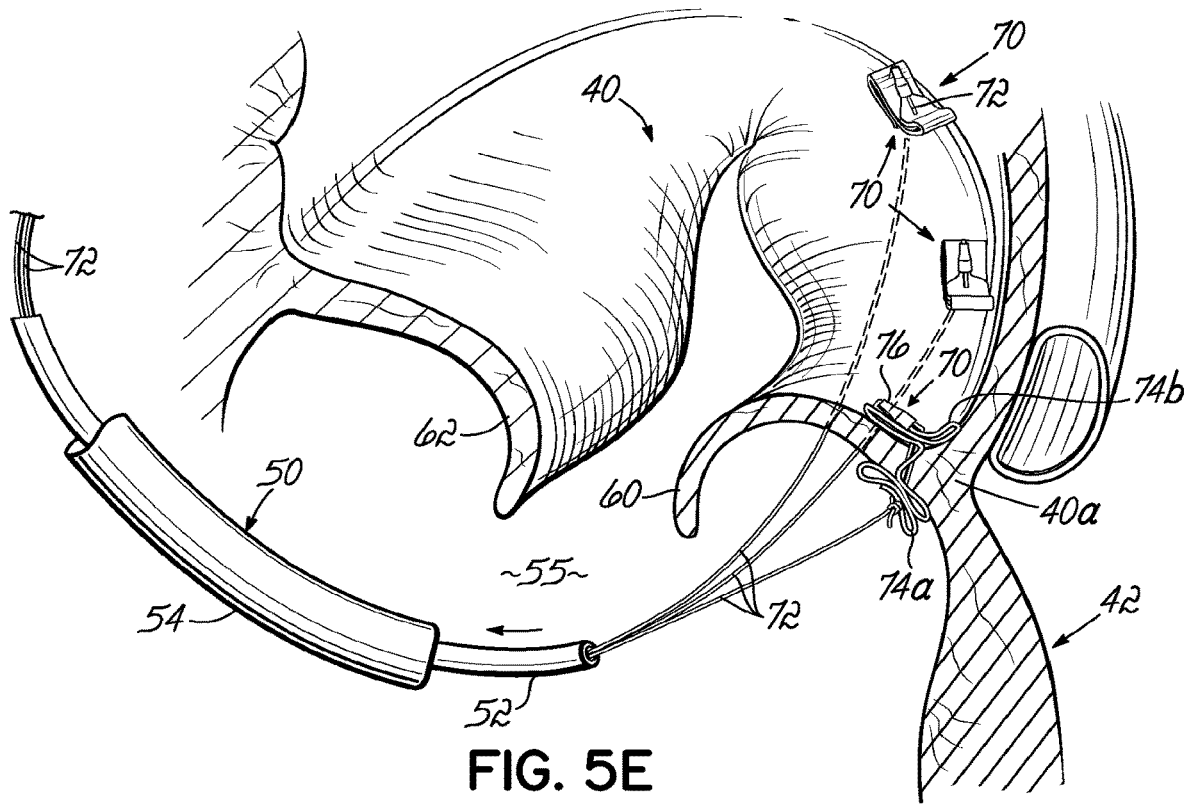

FIG. 5E

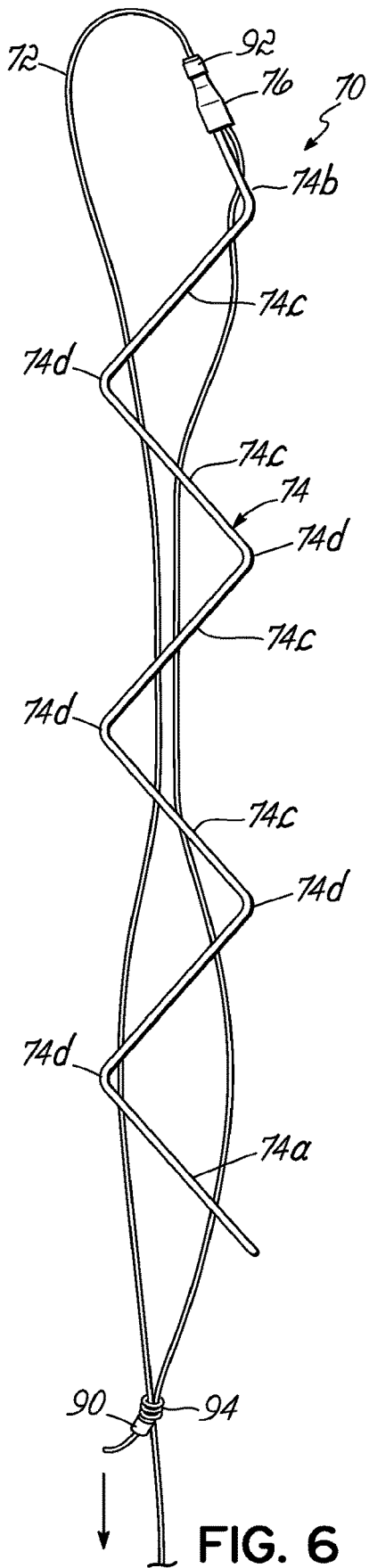

FIG. 6

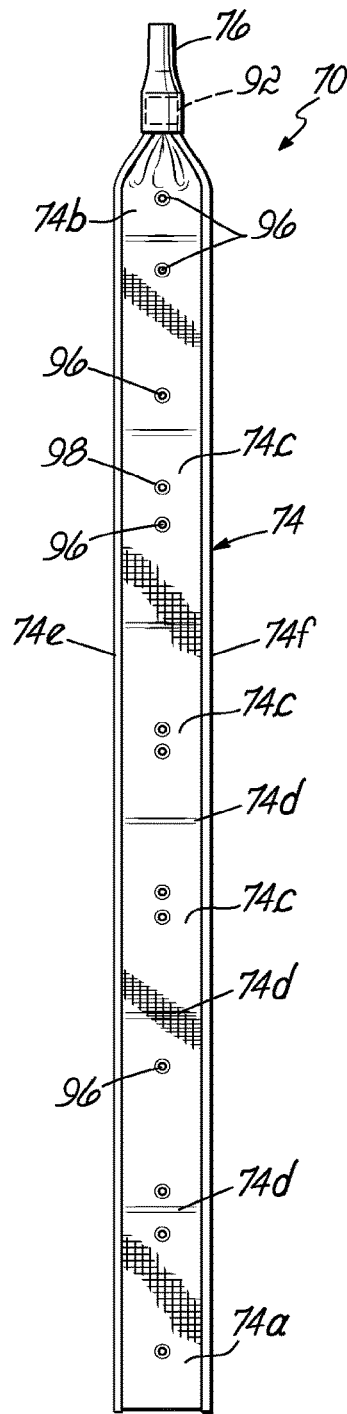

FIG. 7

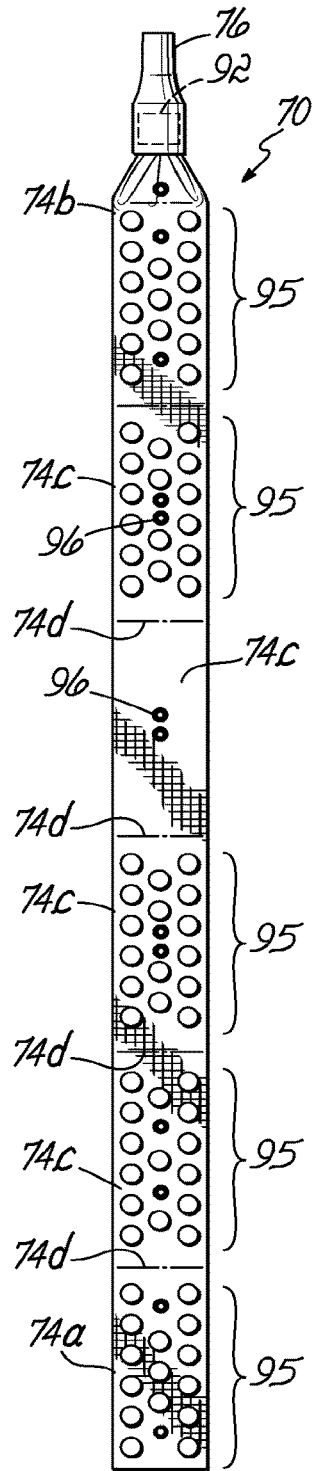

FIG. 7A

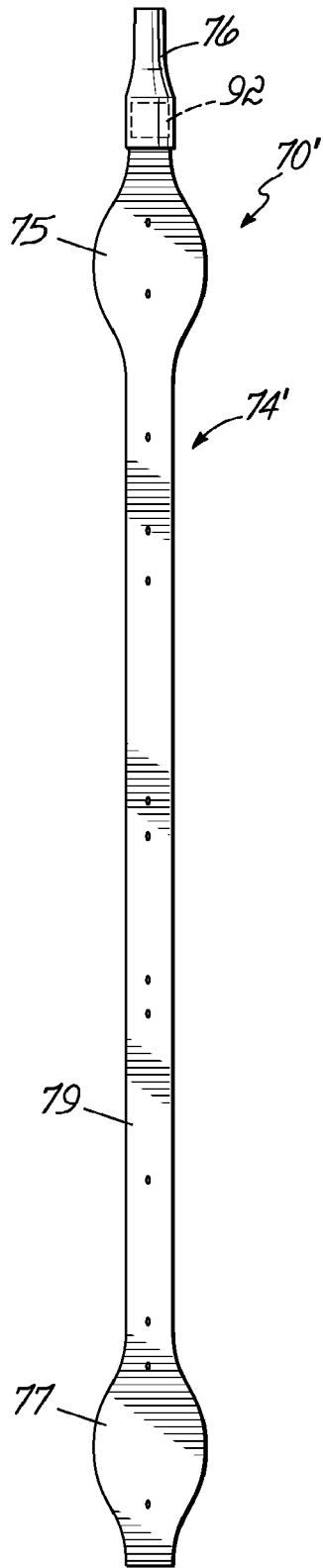

FIG. 7B

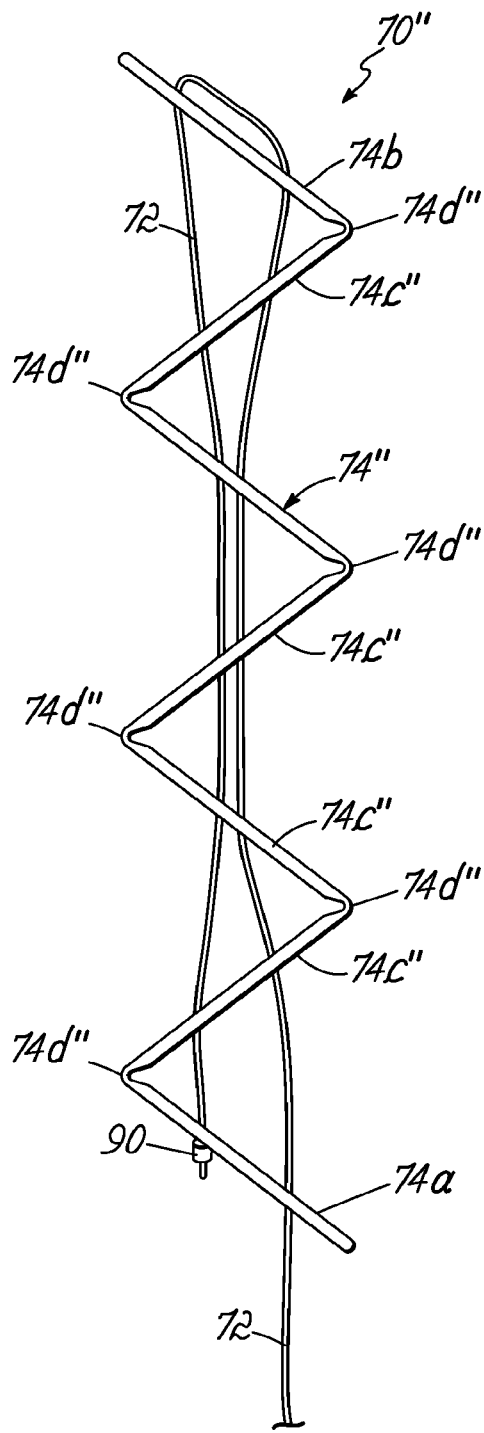

FIG. 7C

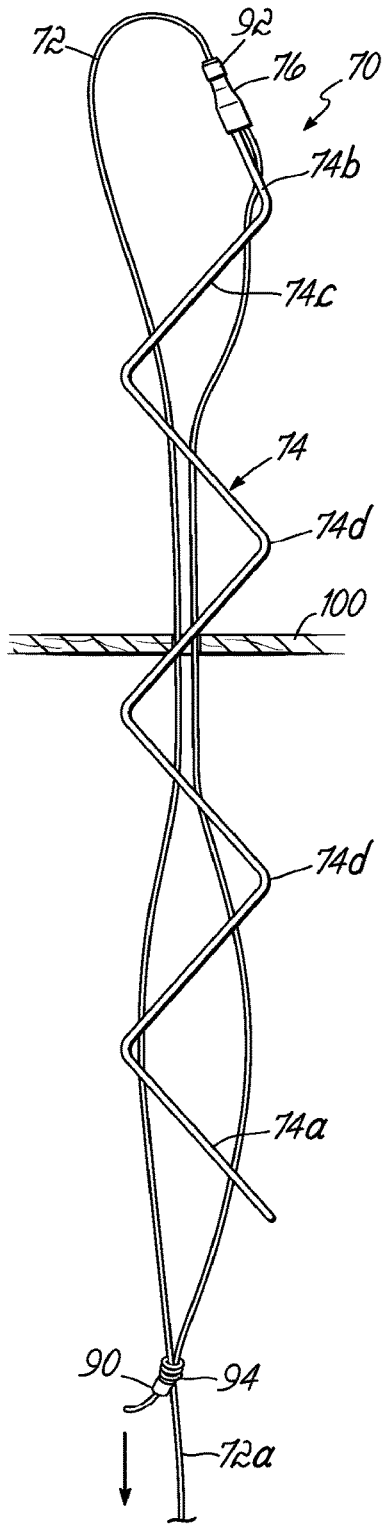

FIG. 8A

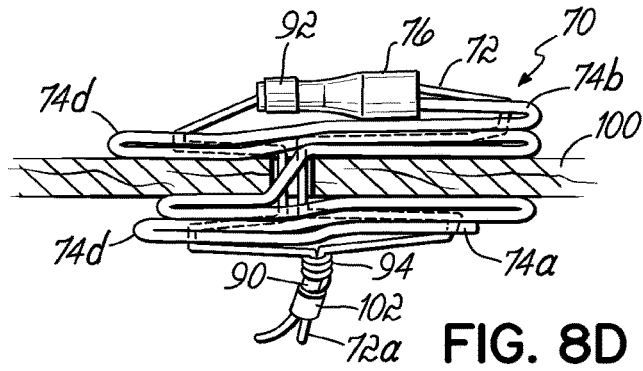

FIG. 8D

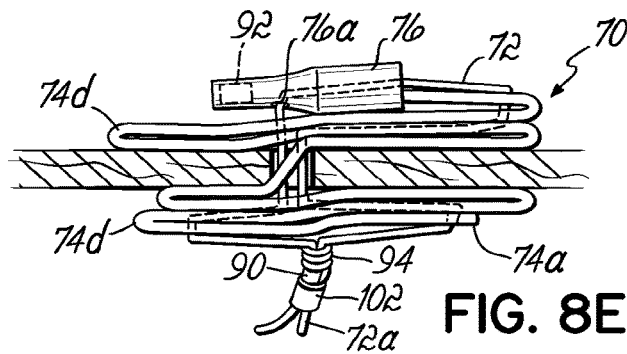

FIG. 8E

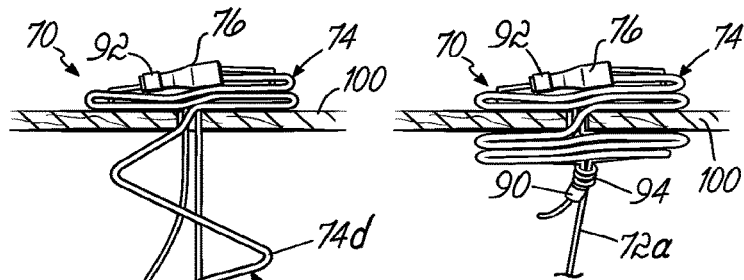

FIG. 8C

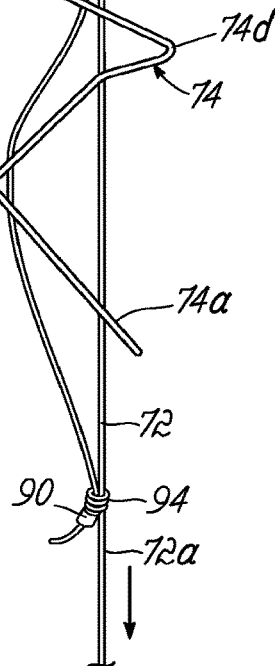

FIG. 8B

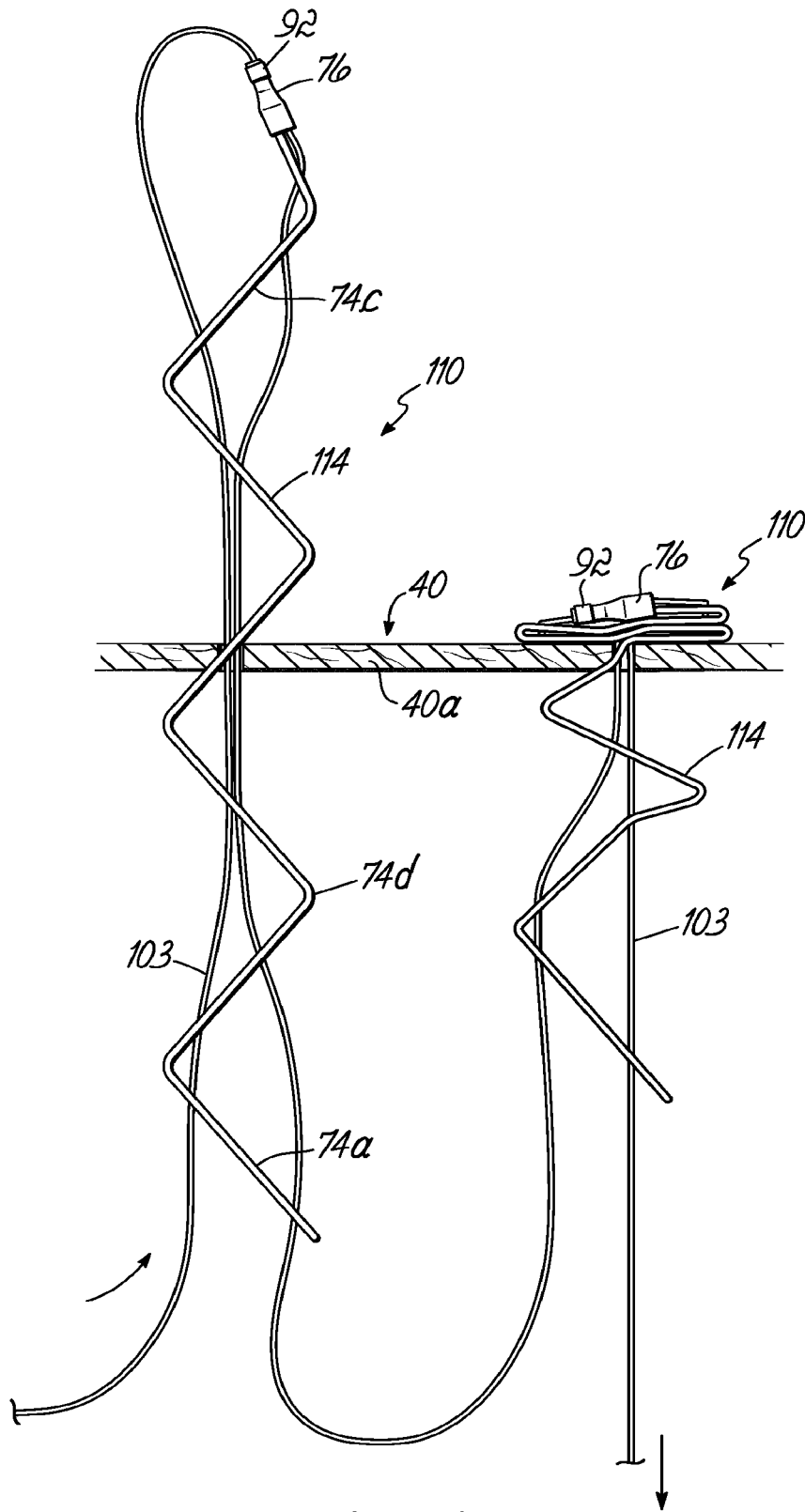

FIG. 9A

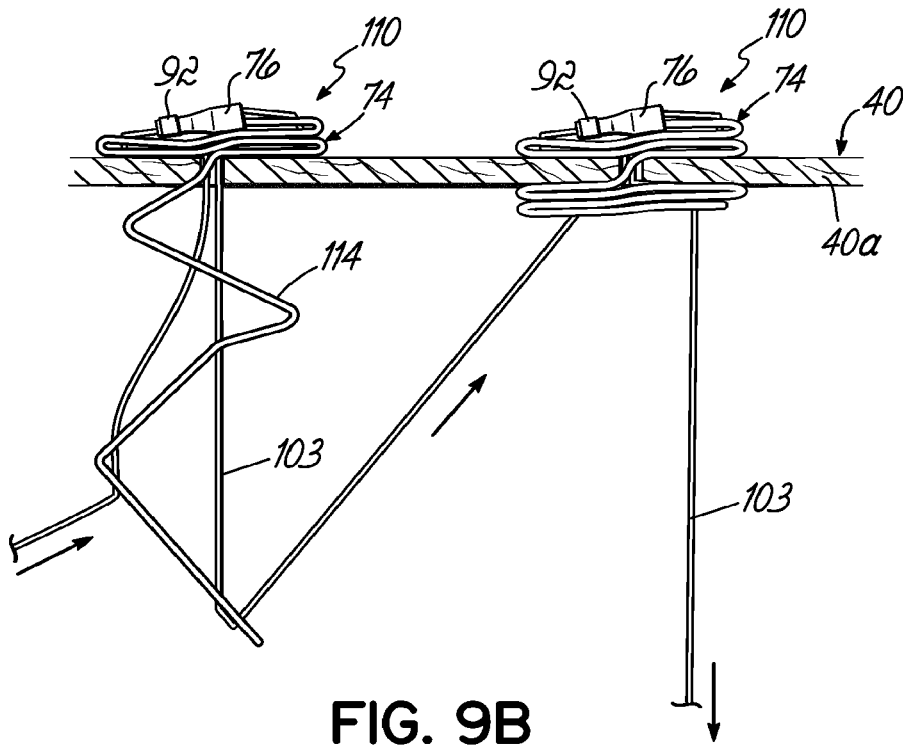

FIG. 9B

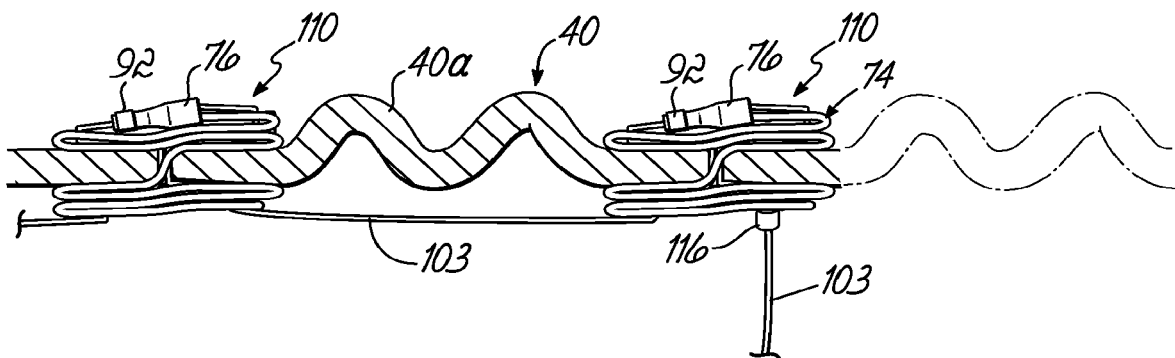
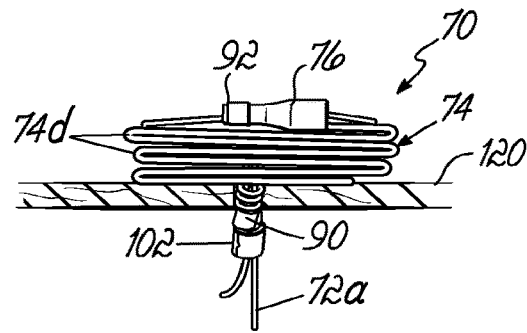
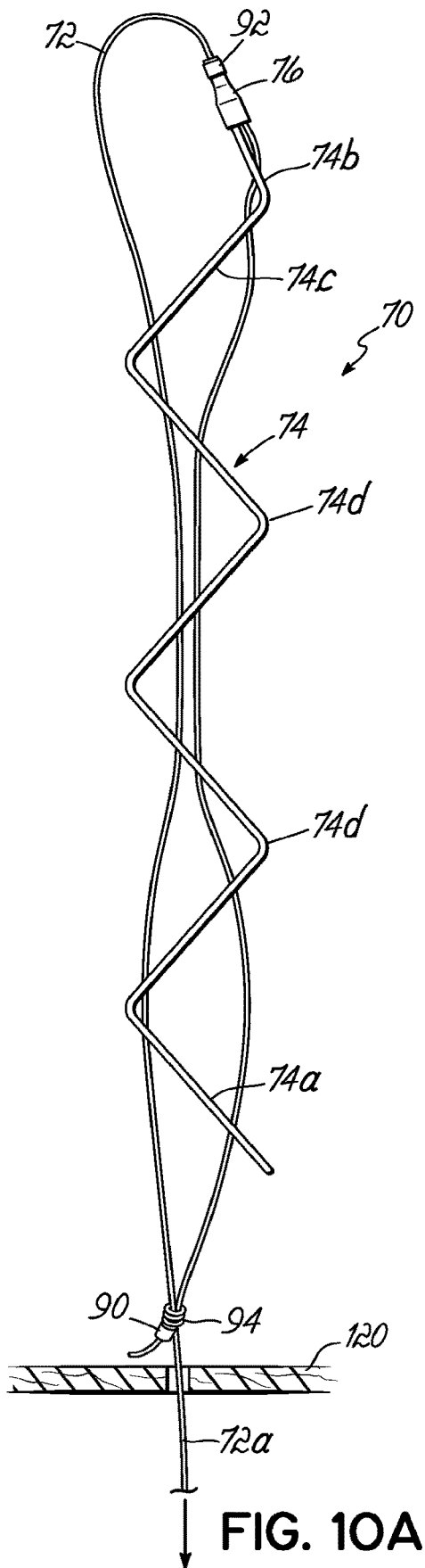

FIG. 9C





## TISSUE ANCHOR AND ANCHORING SYSTEM

### CROSS-REFERENCE TO RELATED APPLICATIONS

This application is a continuation of U.S. patent application Ser. No. 14/581,264, filed Dec. 23, 2014, which is a continuation of U.S. patent application Ser. No. 12/273,670, filed Nov. 19, 2008, which is a divisional of U.S. patent application Ser. No. 11/174,951, filed Jul. 5, 2005, now U.S. Pat. No. 8,951,285, issued Feb. 10, 2015, the contents of each of which are incorporated by reference in their entireties.

### TECHNICAL FIELD

The present invention generally relates to tissue anchors and, more particularly, anchors and methods of using such anchors to secure an element or otherwise provide an anchor point to biological tissue and/or to secure at least two tissue portions together.

### BACKGROUND

Many different surgical procedures require that an anchor be used to either establish a strong point of connection for other securing elements or devices relative to a tissue location in a patient, and/or to secure two or more tissue layers (i.e., portions together. In this regard, the term “anchor”, as used herein, is not to be limited to any particular type of tissue fastening or securement application but, rather, encompasses any hard and/or soft tissue-to-tissue securement, tissue-to-device securement, or any other tissue securement application.

One particular area that has received attention in recent years is that of catheter-based surgical procedures. Various tissue anchors have been developed for purposes of deployment and securement with catheter-based technology. However, there are still limitations in current technology. For example, insertion size versus deployment size must be strictly controlled due to the need for catheter diameters to be maintained relatively small. Many catheter-based tissue anchor systems have very specialized uses and are not versatile for use in many different tissue fastening or securement operations.

There is generally a need for a simpler, more versatile tissue anchor which may be deployed and securely fastened to tissue in a catheter-based operation or a non-catheter-based operation.

### SUMMARY

In one aspect, the invention provides a tissue anchor comprising a generally flexible anchor member capable of being inserted through tissue and moving between an elongate configuration and a shortened configuration suitable for anchoring against at least one side of the tissue. The anchor member includes a proximal end portion, a distal end portion, and a compressible intermediate portion between the proximal end portion and the distal end portion. A tensioning member is operatively connected to the anchor member such that the anchor member can slide relative to the tensioning member. The tensioning member may be pulled to cause the anchor member to move relative to the tensioning member from the elongate configuration to the shortened configuration. In the shortened configuration, the

compressible intermediate portion of the anchor member can compress or shorten and thereby adjust to the thickness of the tissue between the proximal and distal end portions.

In another aspect of the invention, a tissue anchor is provided comprising a flat, generally flexible anchor member capable of movement between an elongate configuration suitable for deployment and a shortened configuration suitable for anchoring against tissue. A tensioning member is operatively connected to the anchor member such that the anchor member can slide relative to the tensioning member. The tensioning member is capable of being pulled to cause the anchor member to move relative to the tensioning member from the elongate configuration to the shortened configuration.

In a further aspect of the invention, a tissue anchor is provided comprising a flat anchor member formed from a strip of fabric material and capable of movement between an elongate configuration suitable for deployment and a shortened configuration suitable for anchoring against tissue. A tensioning member is operatively connected to the anchor member such that the anchor member can slide relative to the tensioning member. The tensioning member is capable of being pulled to cause the anchor member to move relative to the tensioning member from the elongate configuration to the shortened configuration. A lock member is provided for securing the anchor member in the shortened configuration.

In a further aspect of the invention, a tissue anchor is provided comprising a flat, generally flexible anchor member capable of being inserted through tissue and moving between an elongate configuration suitable for deployment through a catheter and a shortened configuration suitable for anchoring against the tissue. A tensioning member is operatively connected to the anchor member such that the anchor member may slide relative to the tensioning member. The tensioning member is capable of being pulled to cause the anchor member to move relative to the tensioning member from the elongate configuration to the shortened configuration against the tissue.

In another aspect of the invention, a tissue anchor is provided comprising a flat elongate strip formed from a generally flexible material and having proximal and distal end portions. A tensioning member having first and second ends is operatively connected to the elongate strip such that pulling on the first end of the tensioning member causes the proximal and distal end portions of the elongate strip to move toward each other to a shortened configuration suitable for anchoring against the tissue.

In certain aspects, the anchor member is advantageously formed as a flat, generally flexible strip of material, while in other aspects it need not be a flat strip but may have other shapes, such as tubular, that may or may not be capable of assuming a flat shape. Various optional features may be incorporated into any or all of the various embodiments of the tissue anchor. For example, the tissue anchor may be formed from a material selected from at least one of: natural fibers, synthetic fibers, polymers, and metals. Such materials may be absorbable or nonabsorbable, and may be radiopaque or at least partially radiopaque. The tensioning member may further comprise a suture, or any other suitable flexible, semi-rigid or rigid tensioning member. The tensioning member may include a stop member engaged with the anchor member, such as a knot in the tensioning member, or a separate stop member (e.g., a crimp) engageable with the anchor member. The tensioning member may, for example, extend through the anchor member at multiple locations between the proximal end portion and the distal end portion. Such coupling of the tensioning member and the anchor

member may be configured in many different manners depending, for example, on the desired configuration of the anchor member upon pulling the tensioning member and moving the anchor member into the shortened configuration. In one embodiment, at least one fold is formed upon pulling the tensioning member. Multiple folds may be formed in a generally zig-zag or accordion fashion. A lock member may be provided and engageable with the tensioning member to retain the anchor member in the shortened configuration. The tissue anchor may include at least one radiopaque marker on one or both of the anchor member and the tensioning member. For example, a first radiopaque marker may be located near the proximal end portion when the anchor member is in the shortened configuration and a second radiopaque marker may be located near the distal end portion when the anchor member is in the shortened configuration. The distal end portion of the anchor member may include a relatively more rigid tip as compared to the anchor member and having a reduced width as compared to an adjacent portion of the anchor member. The anchor member itself may be designed in any of numerous manners, including designs that have a uniform width along the length thereof, and designs that have a varying width along the length. Other features may be incorporated such as edge portions that are slightly more rigid than a central area of the anchor member. Entire sections of the anchor member may be relatively rigid as compared to fold line portions thereof while still resulting in a generally flexible anchor member. As necessary, hinge portions, such as living hinges, may be designed into the anchor member to allow for folding or other shortening action of the anchor member. While a tensioning member is specifically disclosed herein for activation purposes (that is, activating the anchor member from the elongate configuration to the shortened configuration), the invention in various combinations may utilize other types of activation, such as compressive activation.

Each of the embodiments of the tissue anchor may be part of a catheter-based anchoring system having a delivery catheter and a suitable deploying device associated with the delivery catheter and operable to extend the anchor member from the delivery catheter. The deploying device may further comprise a deploying catheter at least partially containing the anchor member and at least partially contained within the delivery catheter.

The invention further provides for various methods of anchoring tissue as generally described herein. For example, in one aspect a method of anchoring tissue is provided comprising inserting a generally flexible elongate anchor member through the tissue, and pulling a first end of a tensioning member coupled for sliding movement relative to the first anchor member to draw the proximal and distal end portions toward each other and to compress the intermediate portion into the shortened configuration with at least one of the proximal and distal end portions engaged against the tissue.

In another aspect of the invention, a method of tissue anchoring is provided comprising inserting the generally flexible flat elongate strip having proximal and distal end portions through the tissue, and pulling a first end of a tensioning member operatively connected to the strip to draw the proximal and distal end portions of the strip toward each other into the shortened configuration engaged against the tissue.

In another aspect, a method of tissue anchoring is provided comprising inserting the generally flexible flat elongate strip having proximal and distal end portions through the tissue, and pulling a first end of a tensioning member

operatively connected to the strip to configure at least a portion of the strip into a shortened configuration engaged against the tissue.

In each of the embodiments engagement of the anchor member against the tissue may be engagement against opposite sides of at least one tissue layer, or engagement against only one side of at least one tissue layer.

Additional features and advantages of the invention will become readily apparent to those of ordinary skill in the art upon review of the following detailed description of the illustrative embodiments taken in conjunction with the accompanying illustrative figures.

#### BRIEF DESCRIPTION OF THE DRAWINGS

FIG. 1 is a perspective view of a tissue anchor constructed in accordance with a first embodiment of the invention.

FIG. 2A is a side view of the tissue anchor shown in FIG. 1, with the tissue anchor deployed through a layer of tissue.

FIG. 2B is a side view similar to FIG. 2A, but illustrating the distal portion of the tissue anchor being moved toward the layer of tissue.

FIG. 2C is a side view similar to FIG. 2B, but showing the distal portion fully compressed and engaged against the layer of tissue.

FIG. 2D is a side view similar to FIG. 2C but illustrating the proximal portion of the tissue anchor being moved toward the layer of tissue.

FIG. 2E illustrates the proximal and distal portions of the tissue anchor fully compressed against opposite sides of the layer of tissue.

FIG. 2F is an enlarged cross sectional view illustrating the fully deployed and fastened anchor with a layer of tissue between proximal and distal anchor portions.

FIG. 3 is a side cross sectional view similar to FIG. 2F, but illustrating the fastening of two layers of tissue between the proximal and distal anchor portions.

FIGS. 4A-4F are perspective views illustrating successive steps in an annuloplasty procedure on the mitral valve of a patient utilizing tissue anchors of the first embodiment.

FIGS. 5A-5E are perspective views illustrating a mitral valve annuloplasty procedure utilizing tissue anchors constructed according to a second embodiment of the invention.

FIG. 6 is a side elevational view illustrating the tissue anchor constructed in accordance with the second embodiment.

FIG. 7 is a front view of the elongate strip portion of the anchor.

FIG. 7A is a front elevational view similar to FIG. 7, but illustrating one embodiment of radiopaque markers used on the elongate strip.

FIG. 7B is a front elevational view of an alternative anchor strip having a varying width along its length.

FIG. 7C is a side elevational view of another alternative anchor strip utilizing more rigid fold sections separated by living hinges.

FIGS. 8A-8D are respective side views illustrating a sequence of steps used for securing the tissue anchor of the second embodiment to a layer of tissue.

FIG. 8E is a view similar to FIG. 8D, but illustrating an alternative tip and tensioning member arrangement.

FIGS. 9A-9C are respective side elevational views illustrating an annuloplasty procedure in which two tissue anchors of the second embodiment are daisy-chained together with a single tensioning member to plicate the tissue between the anchors in a more integrated procedure.

FIGS. 10A and 10B are respective side elevational views illustrating the tissue anchor of the second embodiment used to provide an anchor or securement location on only one side of a tissue layer.

#### DETAILED DESCRIPTION OF ILLUSTRATIVE EMBODIMENTS

Referring first to FIG. 1, a tissue anchor 10 constructed in accordance with a first embodiment of the invention generally includes a tensioning member 12, such as a suture, extending through spaced apart points along a flat elongate strip 14 of flexible material, such as a surgical grade fabric. It will be appreciated that the tensioning member 12 may take other forms other than suture material, such as cable or any other small diameter member having a high enough tensile strength for the intended anchoring use. The elongate strip 14 may also take various forms such as woven or nonwoven fabrics, polymers, metals or other suitable materials or combinations of materials. One or more separate pledgets or other securement members (not shown) may be used in conjunction with the elongate strip 14 for added securement and/or concealing the elongate strip 14 and, for example, thereby inhibiting blood clotting within or adjacent to the folds that will be formed in the strip 14.

A woven or nonwoven material may contain additional materials, such as threads, beads or other elements that cause at least portions of the strip 14 to be radiopaque. Currently, a surgical grade fabric constructed from polyester, such as Dacron®, is contemplated for use in constructing the strip 14. One of many possible alternative materials for use in constructing strip 14 is polytetrafluoroethylene (PTFE). Tissue anchor 10 may be partly or wholly formed from materials that are absorbed into the patient's tissue over time, depending on the intended use. The edges and/or other portions of the strip 14 may be suitably modified to prevent fraying, such as by being coated with a material that locks the fibers in place, or otherwise modified in a manner that locks the fibers at least at the edges of the strip 14 in place.

The suture 12 may extend from a proximal end portion 14a of the fabric strip 14 to a distal end portion 14b and then loop back through spaced apart points of the fabric strip 14 to the proximal end portion 14a where a knot 16 or other stop member is located for reasons to be described below. As will become apparent, the suture 12 extends through spaced apart locations along the elongate strip 14 such that tensioning of the suture 12 or other tensioning member will cause the elongate strip 14 to form folded portions 14c when the tensioning member 12 is placed under tension or pulled. Thus, the elongate strip 14 is activated in this manner between essentially an elongate deployment orientation or configuration, such as shown in FIG. 1, and a shortened configuration, such as a folded or otherwise shortened configuration having an expanded width in at least one dimension as compared to the elongate deployment configuration. It will be appreciated that the deployment orientation may take on various forms due to the flexible nature of the strip 14, especially when using a highly flexible fabric or other material. For example, a fabric material or other similarly flexible materials may be folded or otherwise deformed for carrying purposes within a catheter and/or during deployment to a tissue site and then suitably activated at the tissue site.

More specifically referring to FIGS. 2A-2E, the elongate strip 14 and attached suture 12 are initially inserted through at least one tissue layer 20 as generally shown in FIG. 2A. One end or portion 12a of the suture 12 is then pulled and

thereby placed under tension. It will be appreciated that, for catheter-based procedures, suture portion 12a may extend to a location outside the patient's body for pulling or tensioning, or it may be grasped by a suitable mechanism within the catheter and pulled or tensioned. Pulling suture portion 12a may initially draw the distal portion 14b of the elongate strip 14 toward the layer of tissue 20 as shown in FIG. 2B. Once the distal portion 14b is compressed against the layer of tissue 20, the proximal portion 14a begins to be drawn and compressed against a proximal side of the tissue 20 as shown in FIGS. 2C-2E. This occurs because end 12a of the suture 12 is being pulled downwardly (as viewed for purposes of discussion in FIGS. 2C-2E) and, since the suture 12 is looped in a reverse direction through distal end portion 14b of the elongate strip 14, the knot 16 at the end of the suture 12 moves upwardly and brings the proximal portion 14a of the elongate strip 14 with it. In this manner, the proximal portion 14a of the elongate strip 14 is being folded and drawn along the suture 12 toward the layer of tissue 20 and then firmly compressed against the proximal side of the layer of tissue 20 as shown in FIG. 2E. As further shown in FIG. 2F, a suitable locker element, such as a crimp member 22, a knot or other element may be used to maintain the suture 12 and elongate strip 14 in the positions shown in FIG. 2F securely anchoring the proximal and distal portions 14a, 14b of the elongate strip 14 folded against opposite sides of the tissue 20.

As further shown in FIG. 3, the same general procedure may be used to secure two distinct tissue layers 30, 32 together by initially extending the elongate strip 14 and tensioning member 12 through at least two layers of tissue 30, 32. In this manner, for example, two layers of tissue 30, 32 may be securely fastened together. This may, for example, involve two entirely different layers and even types of tissue or the same layer of tissue which has been folded over to effectively form two layers (i.e., portions) of tissue.

FIGS. 4A-4E schematically illustrate an annuloplasty procedure performed on a mitral valve 40 of a heart 42 utilizing tissue anchors 10 as described above in regard to the first embodiment. Performance of the annuloplasty procedure may have many variations, but is generally illustrated by the placement of at least two tissue anchors 10 and securement of the two anchors 10 together, such as with one or more tensioning members 12 therebetween. For an additional illustrative description of catheter-based annuloplasty procedures that may utilize any of the tissue anchors within the scope of the present invention, reference may be made to U.S. patent application Ser. No. 10/948,922, filed on Sep. 24, 2004, assigned to the assignee of the present invention, and the disclosure of which is hereby entirely incorporated by reference herein.

As illustrated in FIG. 4A, a first tissue anchor 10 is deployed through a catheter device 50 which may, for example, have an inner tubular member 52 or deploying catheter received within an outer tubular member 54 or delivery catheter. The tissue anchor 10 and tensioning member 12 are carried within the inner tubular member 52 and are deployed from a distal end 52a thereof. To ensure that proper force is applied to penetrate the tissue, tissue anchor 10 may be deployed or extended after the inner tubular member 52 has been inserted through tissue at the annulus 40a of the mitral valve 40. This is best illustrated in FIG. 4B. The inner tubular member 52 is withdrawn from the annulus tissue 40a either before, during or after activation of the distal end portion 14b of the elongate strip 14. As previously described, activating (e.g., compression, folding or otherwise shortening) the elongate strip 14 by pulling the suture

12 causes the distal end portion 14b and then proximal end portion 14a to be securely compressed and folded against opposite sides of the annulus tissue 40a. This procedure is repeated at least one additional time to securely fasten an additional tissue anchor 10 at a location spaced from the initial location. For example, the initial location may be at location P2 of the mitral valve annulus 40 while the second location may be spaced on either side of location P2. Catheter device 50 may be inserted into the location of annulus 40a in various manners, but is shown being inserted downwardly through the aortic valve 53 into the left ventricle 55, and curving upward toward the mitral valve annulus 40a.

In the illustrative example shown in FIG. 4E, three tissue anchors 10 have been deployed and securely fastened to the annulus tissue 40a. As shown in FIG. 4F a suture locker 56 may then be deployed and used to maintain relative position and, therefore, tension between each of three respective tensioning members or sutures 12 associated with the three tissue anchors 10 after the tissue anchors 10 have been pulled closer to each other thereby plicating the tissue 40a between the anchors 10. This essentially shortens the valve annulus 40a and pulls the posterior leaflet 60 toward the anterior leaflet 62 to prevent leakage through the valve 40, i.e., to achieve better coaptation of the posterior and anterior leaflets 60, 62 during systole.

FIGS. 5A-5E illustrate a similar annuloplasty procedure on a mitral valve 40 utilizing a second embodiment of a tissue anchor 70 and a modified method of deployment and activation. In general, the differences between anchor 70 and anchor 10 will be described below with the understanding that all other attributes, options and features associated with anchor 70 may be as described above in connection with anchor 10. As shown in FIG. 5A, in this embodiment a tensioning member 72 is again used to activate a flexible, elongate flat strip 74 having proximal and distal end portions 74a, 74b. Strip 74 includes a tip 76 that is formed or otherwise secured on the distal end portion 74b. The tensioning member 72 and the tip 76 are arranged such that the tensioning member 72 slides relative to the tip 76. More particularly, the tensioning member 72 can be threaded through the tip 76. Tip 76 is made to be relatively rigid as compared to other flexible portions of strip 74 and of smaller diameter than the width of strip 74. Therefore, tip 76 helps to penetrate the annulus tissue 40a as the inner tubular member 52 and the elongate strip 74 are extended through the tissue 40a. A wire 73 may be used to push the tip 76 out of the tubular member 52 at the desired time. The tip 76 may protrude slightly from the inner tubular member 52 as the tissue 40a is penetrated to assist with piercing the tissue 40a. The tip 76 may also assist with forcing distal portion or half 74b of strip 74 into a folded or otherwise shortened configuration. To help prevent the distal portion 74b of the elongate strip from pulling back through the tissue 40a as the inner tubular member 52 is withdrawn from the annulus tissue 40a, the free end of the tensioning member 72 is pulled while the inner tubular member 52 is still penetrated through the tissue 40a and into the left atrium 80 from the left ventricle 55. This forms the distal portion 74b into a folded or otherwise shortened configuration as shown in FIG. 5B. The inner tubular member 52 may then be withdrawn without also withdrawing the elongate flexible strip 74 with it, as shown in FIG. 5C. The proximal portion 74a of the elongate strip 74 is then deployed by pulling the inner tubular member 52 further in a proximal direction, and thereby exposing the full length of strip 74. The tensioning member 72 is pulled or tensioned so as to draw and

compress the proximal portion 74a of the elongate strip 74 into a folded, shortened condition against an underside of the annulus tissue 40a as shown in FIG. 5D. As with the previously described annuloplasty procedure using the first embodiment of the tissue anchor 10, this is repeated as many times as necessary to create the necessary number of tissue plications. FIG. 5E illustrates this by way of an exemplary view of three successive tissue anchor securement locations with tissue anchors 70 that may be drawn together and locked in place to achieve and retain the plications as described in connection with FIG. 4F. Such plications reduce or close the gap between the posterior and anterior leaflets 60, 62, during systole.

FIG. 6 is a side elevational view of the tissue anchor 70 as shown and described with respect to the annuloplasty procedure of FIGS. 5A-5E. This embodiment differs from the first embodiment in a number of different manners, in addition to the use of a distal tip 76 for tissue penetration purposes. For example, the elongate strip 74 is somewhat shorter than the elongate strip 14 utilized in the first embodiment. For example, the strip 74 may be about 40 mm long by about 3 mm wide. Of course, any other desired dimensions and shapes may be used depending on application needs. This may be desirable to achieve a lower profile deployed and fastened configuration with fewer folds that may lead to more versatile applications, lower incidents of blood clotting, easier use, etc. In addition, respective proximal and distal radiopaque bands 90, 92 are secured to the suture 72 at the proximal end portion of the strip 74 and to either the interior or exterior of the distal tip 76. Under a fluoroscope, these bands or other markers 90, 92 will indicate to the surgeon that the anchor 70 has been deployed, activated and fully compressed and/or fastened as necessary during the procedure. The tip 76 itself may alternatively be formed from a radiopaque material. In this second embodiment, the knot 94 formed in the suture 72 or other tensioning member is a slip knot through which another portion of the suture 72 slides during activation of the tissue anchor 70. It will be appreciated that this slip knot 94 may be replaced by another element which serves essentially the same purpose but takes the form, for example, of a small tubular element or other feature similar in function to a slip knot.

As further shown in FIGS. 6 and 7, the tensioning member or suture 72 can advantageously extend through respective fold portions 74c of the elongate strip 74 in essentially an hourglass configuration. Specifically, adjacent portions of the suture 72 located near the proximal and distal end portions 74a, 74b of the strip 74 are spaced farther apart than the adjacent portions of the suture 72 in the middle of the strip 74. As further shown in FIG. 7A, radiopaque markers, such as distinct areas of dots 95, may be used for enabling the surgeon to visualize the folds of the elongate strip 74 during deployment and securement of the elongate strip 74. These dots or other radiopaque markers may be printed on the strip 74. For example, dots 95 or other markers may be formed with a platinum powder base ink or other suitable material that is radiopaque and biologically compatible. This radiopaque material may also add stiffness to the fold sections 74c thereby helping to maintain the fold sections 74c flat and increasing retention force on the tissue. Meanwhile, the fold lines 74d between fold sections 74c can remain highly flexible to create tight radius fold lines. As further shown in FIG. 7, each of the holes 96 that the tensioning member or suture 72 is received through may be marked by circles 98 surrounding each hole 96 or other markers for visualizing purposes during assembly of the tensioning member or suture 72 with the elongate strip 74.

Optionally, holes 96 may be eliminated and the suture 72 may be threaded with a needle through the strip 74. One could also, for example, choose different sets of holes 96 along strip 74 for receiving the tensioning member or suture 72 thereby changing the width of the folds and/or number of folds and/or shape of the folds depending on the application needs or desires of the surgeon. The tensioning member or suture 72 may be threaded or otherwise attached along the strip 74 in any number of manners including, for example, x-patterns or other crossing patterns, zig-zag patterns, etc. that may alter the folded or otherwise shortened or compressed footprint of the anchor into various beneficial shapes, such as flower shapes, circular shapes or other rounded shapes, ball shapes or other configurations. Modifications of the manner in which the tensioning member or suture 72 is threaded or otherwise attached along the length of strip 74 may result in higher or lower tensioning force being required to compress the anchor and/or higher or lower friction holding force that may help maintain the anchor in the compressed or shortened configuration. The width of the elongate strip 74' may be varied along its length, such as by tapering, stepping, or forming an hourglass shape or shapes along the length of the strip 14. For example, as illustrated in FIG. 7B, having proximal and distal end portions 75, 77 of wider dimension than an intermediate or middle portion or portions 79 along the length of strip 74' will allow these wider portions 75, 77 may cover over the more intermediate folded portions 79 and prevent unnecessary contact with adjacent tissue during use. It will be appreciated that like reference numerals are used herein to refer to like elements in all embodiments and reference numerals with prime marks (') or double prime marks (") refer to like elements that have been modified in a manner as described herein or otherwise shown in the associated figure. Strip 74 may have variable stiffness including, for example, a relatively rigid perimeter or relatively rigid edges 74e, 74f (FIG. 7) or intermittent relatively rigid sections 74c" separated by flexible sections such as living hinges 74d" (FIG. 7C) that may aid in folding and securing the elongate strip 74" into a folded condition.

FIGS. 8A-8D illustrate a series of steps for deploying and securely fastening the tissue anchor 70 of the second embodiment to a layer of tissue 100. Generally, as shown in FIG. 8A, the combination of the elongate strip 74 and tensioning member or suture 72 is deployed through the layer of tissue 100. One end or portion 72a of the suture 72 that extends through the slip knot 94 is then pulled. This causes the distal portion 74b of the elongate strip 74 to fold and compress against the distal side of the tissue layer 100. As shown in FIG. 8B, further pulling of the tensioning member 72 causes the slip knot 94 to ride upwardly or distally along the suture 72 and against a proximal portion 74a of the elongate strip 74 thereby folding and compressing the proximal portion 74a against the proximal side of the tissue layer 100 as shown in FIG. 8C. As shown in FIG. 8D, a suitable crimp or locking element 102 may be used to securely lock the slip knot 94 in place relative to the suture or tensioning member segment which extends therethrough. This will lock the entire anchor 70 in place with the respective proximal and distal folded strip portions 74a, 74b securely retaining the tissue layer or layers 100 therebetween. FIG. 8D shows the tip 76 acting as a retainer on top of the distal end portion 74b to assist in holding the distal end portion 74b in place. FIG. 8E shows an alternative in which the tensioning member is threaded through at least one hole 76a more centrally located in the tip. Yet another alternative would be to thread the tensioning member

through two centrally located holes instead of through the proximal end of the tip 76 and one centrally located hole 76a as shown in FIG. 8E. These alternatives allow the tip 76 to act more like a "T"-bar with forces acting in a more perpendicular or normal manner relative to the distal end portion 74b of the strip 74.

FIGS. 9A-9C illustrate another alternative embodiment of a plication procedure, for example, for use during annuloplasty on a mitral valve annulus 40a. In this regard, a single tensioning member, such as a suture 103 or other member may be used to deploy, fasten and draw together at least two separate tissue anchors 110. As shown in FIG. 9A, first and second tissue anchors 110 may be respectively deployed at spaced apart locations along the mitral valve annulus 40a. Each tissue anchor 110 includes an elongate strip 114 of flexible material, such as fabric or other material as described above, as well as a single suture 103 or tensioning member extending through each of the elongate strips 114. Upon deployment of the two tissue anchors 110 through the tissue layer 40 at spaced apart locations, the free end of the suture 103 or tensioning member is pulled thereby securely fastening the first tissue anchor 110 as shown in FIGS. 9A and 9B and subsequently securely fastening the second tissue anchor 110 to the annulus tissue 40a. Upon further pulling or tensioning of the suture 103, the tissue anchors 110 will be drawn together to plicate the tissue 40 therebetween as shown in FIG. 9C. A crimp or other locker member 116 may then be used to lock in the desired amount of plication by crimping onto the free end of the suture 103 adjacent to the slip knot 94 of the first tissue anchor 110 as shown in FIG. 9C. The free end of the suture 103 may then be cut to eliminate or reduce the length of the suture tail.

FIGS. 10A and 10B illustrate a tissue anchor 70 of the second embodiment, for example, being used to provide an anchor or securement location on only one side of a tissue layer 120. In this regard, the tissue anchor 70 may be extended entirely through the tissue layer(s) 120. The free end of the suture or tensioning member 72 is then pulled proximally to compress and fold the elongate strip 74 against the distal side of the tissue layer 120 as shown in FIG. 10B. It will be appreciated that activation of strip 74 occurs similarly to the other described embodiments, except that the activated portion (that is, the folded or otherwise shortened portion) is located entirely on one side of the tissue layer 120. As illustrated, the intermediate or middle portion between the proximal and distal end portions of the anchor member shortens to adjust to the amount of tissue contained therebetween (if any) or shortens during the compression process on only one side of the tissue.

While the present invention has been illustrated by a description of various illustrative embodiments and while these embodiments have been described in some detail, it is not the intention of the Applicant to restrict or in any way limit the scope of the appended claims to such detail. Additional advantages and modifications will readily appear to those skilled in the art. The various features of the invention may be used alone or in numerous combinations depending on the needs and preferences of the user.

What is claimed is:

1. An apparatus for use with tissue of an annulus of a heart valve of a subject, the apparatus comprising an annuloplasty implant that comprises:

an elongate fabric member configured to be anchored to the tissue, and to move between an elongate configuration and a shortened configuration, the fabric member having a first end portion, a second end portion, and a

11

compressible intermediate portion between the first end portion and the second end portion; and  
 a tensioning member:  
 having a first tensioning-member end and a second tensioning-member end,  
 defining a first segment and a second segment by being turned back on itself at a turn such that (i) the first segment extends between the first tensioning-member end and the turn, (ii) the second segment extends between the turn and the second tensioning-member end, and (iii) the second segment is alongside the first segment, and  
 operatively connected to the fabric member by the first segment and the second segment being threaded, along the fabric member and alongside each other, between the first end portion and the second end portion, such that the fabric member can slide relative to the tensioning member,

wherein:

the turn of the tensioning member is disposed at the second end portion of the fabric member,  
 the operative coupling of the tensioning member to the fabric member is such that tensioning of the tensioning member causes the fabric member to move from the elongate configuration to the shortened configuration by the tensioning member (i) pulling both the first end portion and the second end portion toward the intermediate portion, and (ii) compressing the intermediate portion, and

the implant is configured to reshape the annulus of the heart valve.

2. The apparatus according to claim 1, wherein the fabric member is formed from a material selected from at least one of: natural fibers, synthetic fibers, polymers, and metals.

3. The apparatus according to claim 2, wherein the tensioning member further comprises a suture.

4. The apparatus according to claim 1, wherein the tensioning member further comprises a suture.

5. The apparatus according to claim 1, wherein the tensioning member includes a stop member engageable with the fabric member.

6. The apparatus according to claim 5, wherein the stop member further comprises a knot in the tensioning member.

7. The apparatus according to claim 1, wherein the tensioning member extends through the fabric member at multiple locations between the first end portion and the second end portion.

8. The apparatus according to claim 1, wherein the fabric member and the tensioning member are configured such that the fabric member forms at least one fold upon pulling the first tensioning-member end.

9. The apparatus according to claim 1, further comprising a lock member engageable with the tensioning member to retain the fabric member in the shortened configuration.

10. The apparatus according to claim 1, further comprising at least one radiopaque marker on at least one of the fabric member and the tensioning member.

11. The apparatus according to claim 1, further comprising a first radiopaque marker located proximate the first end portion of the fabric member is in the shortened configuration and a second radiopaque marker located proximate the second end portion when the fabric member is in the shortened configuration.

12. The apparatus according to claim 1, wherein the implant comprises a tip at the second end portion, the tip being narrower and more rigid than the fabric member.

12

13. The apparatus according to claim 12, wherein the tip acts as a compressive force applying member against the second end portion of the fabric member when the fabric member is in the shortened configuration.

14. The apparatus according to claim 1, wherein the fabric member varies in width along its length when in the elongate configuration.

15. The apparatus according to claim 1, wherein the fabric member includes an edge portion that is more rigid than a central area of the fabric member.

16. The apparatus according to claim 1, wherein at least the first tensioning-member end is disposed at the first end portion of the fabric member.

17. The apparatus according to claim 1, further comprising a catheter device, wherein the annuloplasty implant is configured to be transluminally delivered to the heart valve through the catheter device, with the second end portion distal to the first end portion, such that deployment of the annuloplasty implant from the catheter device exposes the second end portion prior to the first end portion.

18. The apparatus according to claim 1, further comprising a catheter device configured to facilitate securing of the second end portion to the tissue, and to facilitate securing of the first end portion to the tissue subsequently to the securing of the second end portion to the tissue.

19. A system for use with tissue of an annulus of a heart valve of a subject, the system comprising:

an annuloplasty implant that comprises:

an elongate fabric member configured to be anchored to the tissue, and to move between an elongate configuration and a shortened configuration, the fabric member having a first end portion, a second end portion, and a compressible intermediate portion between the first end portion and the second end portion; and

a tensioning member having a first tensioning-member end and a second tensioning-member end, defining a first segment and a second segment by being turned back on itself at a turn such that (i) the first segment extends between the first tensioning-member end and the turn, (ii) the second segment extends between the turn and the second tensioning-member end, and (iii) the second segment is alongside the first segment, and operatively connected to the fabric member by the first segment and the second segment being threaded, along the fabric member and alongside each other, between the first end portion and the second end portion, such that the fabric member can slide relative to the tensioning member; and

a catheter device configured to facilitate securing of the second end portion to the tissue, and to facilitate securing of the first end portion to the tissue subsequently to the securing of the second end portion to the tissue;

wherein the turn of the tensioning member is disposed at the second end portion of the fabric member, the operative coupling of the tensioning member to the fabric member is such that tensioning of the tensioning member causes the fabric member to move from the elongate configuration to the shortened configuration by the tensioning member (i) pulling both the first end portion and the second end portion toward the intermediate portion, and (ii) compressing the intermediate portion, and the implant is configured to reshape the annulus of the heart valve.